



TECHNICAL INSTRUCTION MANUAL
VS-TC
TRANSFER CONTROLLER

Document ID:	NHB-VS-TC-TIM
Version:	3.0
Issue Date:	2024-04-15
Status:	Standard



Contact Information

Nautel Limited

10089 Peggy's Cove Road
Hackett's Cove, NS Canada B3Z 3J4

Toll Free: +1.877.6NAUTEL (662.8835)
(Canada & USA only) or

Phone: +1.902.823.3900 or

Fax: +1.902.823.3183

Nautel Inc.

201 Target Industrial Circle
Bangor, Maine USA 04401

Phone: +1.207.947.8200

Fax: +1.207.947.3693

Customer Service (24-hour support)

+1.877.628.8353 (Canada & USA only)

+1.902.823.5100 (International)

Email: support@nautel.com

Web: www.nautel.com

The comparisons and other information provided in this document have been prepared in good faith based on publicly available information. For verification of materials, the reader is encouraged to consult the respective manufacturer's most recent publication on the official website or through contact with Customer Service.

© Copyright 2024 NAUTEL. All rights reserved.

CONTENTS

Contact Information	iii
<hr/>	
RELEASE CONTROL RECORD	XI
<hr/>	
STANDARD WARRANTY	XIII
Technical Assistance	xv
<hr/>	
ABOUT THIS MANUAL	XVII
Technical Support	xvii
<hr/>	
ABOUT SAFETY	XIX
Electrical Hazards	xix
Lightning Hazards	xx
RF Hazards	xx
Toxic Hazards	xx
Other Hazards	xx
<hr/>	
SAFETY PRECAUTIONS	XXI
Personal Safety	xxi
Training	xxi
Site Orientation	xxi
Voltage Awareness	xxii
First Aid	xxii
Site Safety	xxii
Controlling Access	xxii
Marking Hazards	xxiii
Qualifying Site Personnel	xxiii
Ac Power Protection	xxiii
RF Protection	xxiii

Safety Interlocks	xxiv
Ac Disconnect Switch	xxiv
Equipment Safety	xxiv
Electrostatic Protection	xxiv
Surge Protection	xxiv
Lightning Protection	xxv
Physical Protection	xxv
Earthquake Protection	xxv

GENERAL INFORMATION	1.1
Introduction	1.1
About this Manual	1.1
Transmitter Manuals	1.1
Online Resources	1.1
Mechanical Description	1.2
Dimensions and Clearances	1.2
Weight	1.2
Installation	1.2
Cooling	1.2
Interfacing	1.3
Supported Transmitter Configurations	1.3
Technical Summary	1.4

PREPARATION FOR USE & INSTALLATION	2.1
Preparation for Use	2.1
VS-TC Environment Requirements	2.1
Electrical Power	2.2
System Interface Connections	2.2
Transmitter Interface Connections	2.3
Remote Control Inputs	2.5
Remote Alarm/Status Outputs	2.9

Installation	2.11
Accepting the Shipment	2.11
Installing the VS-TC	2.11
Installing External Control/Monitor Wiring	2.11
Installing Transmitter Interconnect Wiring and Cables	2.11

OPERATING INSTRUCTIONS	3.1
Emergency Shutdown	3.1
Turn Off RF Output	3.1
Complete Shutdown	3.2
External Safety Interlock	3.2
Electrostatic Discharge Protection	3.2
Discharging of Personnel	3.2
Handling/Storage	3.2
Tools/Test Equipment	3.3
Stress Current Protection	3.3
Controls and Indicators	3.3
VS-TC Front Panel	3.3
Local Operation	3.6
Using the Transmitter's UI	3.7
Enabling the VS-TC in the Transmitter	3.10
Selecting the Active Transmitter	3.11
Selecting the Active Audio Source	3.13
Selecting the RF Transfer Mode	3.15
Setting the Audio Transfer Mode	3.17
Selecting the Maintenance Mode	3.19
Setting System RF Control	3.21
Setting the AES Changeover Delay	3.23
Setting the AES Return Delay	3.25
Setting the AES Changeover Level	3.27
Setting the AES Return Level	3.29

Setting the RF Changeover Delay	3-31
Remote Operation	3-33
Using the CONSOLE Port	3-33
Upgrading Firmware	3-49
Requirements	3-49
Procedure	3-49

TROUBLESHOOTING	4.1
Identifying a Fault	4.1
Types of Faults	4.2
Checking Cable Connections	4.4

THEORY OF OPERATION	5.1
System Overview	5-1
VS-TC to VX Serial Converter Assembly (Units 4 and 5)	5-2
Power Loss and Recovery	5-2
VS-TC Transfer Controller	5-2
Transfer Control PWB (A1)	5-2
Button/LED PWB (A2)	5-3
RF Coaxial Transfer Switch (U1)	5-4

PARTS LIST	6.1
How to Locate Information About a Specific Part	6.1
Column Content	6.1
Component Level, Stock Code Column	6.1
Description Column	6.2
Reference Designation Column	6.2
Common Abbreviations/Acronyms	6.2

ELECTRICAL SCHEMATICS	7.1
Component Values	7.1
Graphic and Logic Symbols	7.1
Reference Designations	7.1
Unique Symbols	7.2
Type of Inputs and Outputs	7.2
Logic Level Convention	7.2
Identifying Schematic Diagrams	7.2

MECHANICAL DRAWINGS	8.1
Identifying Mechanical Drawings	8.1
Content of Mechanical Drawings	8.1

Release Control Record

Issue	Date	Reason
3.0	2024-04-15	Release 3 of VS-TC (NAX271B). Added references for the VS-TC's support for the VX150 to VX600 transmitters.

Standard Warranty

Nautel guarantees all mechanical and electrical parts of Nautel Transmitters for a period of forty eight months, and all other Nautel manufactured equipment (including Importers and Exporters) for a period of twelve months from date of shipment, provided the equipment has been installed, operated and maintained in accordance with Nautel's recommendations, and the equipment has not been misused, neglected or modified. Nautel's liability is limited, at the absolute discretion of Nautel, to repairing or replacing returned equipment that to the satisfaction of Nautel has been found defective.

Warranty for third-party items is provided by the Original Equipment Manufacturer. Exercise of such warranty shall be between the Buyer and the Third-Party.

1. Properly qualified technical personnel must install, maintain, and repair the equipment in accordance with Nautel recommendations and good engineering practice.
2. A "Part Failure" shall be deemed to have occurred when the part has become defective, or does not have the characteristics required for the specified equipment performance:
 - a. when the equipment is operated within the design parameters, and
 - b. when the equipment is installed and adjusted according to Nautel's prescribed procedures as stated in the instruction manual.
3. Nautel shall provide replacements for all "Parts" to the Buyer when they become defective during the warranty period, and upon the return of the defective part. Replacement parts warranty to be 90 days or end of original warranty; whichever comes first.
4. If the Buyer receives a replacement module, as part of Nautel's module exchange program, the old module must be returned to Nautel within 30 days of receipt of the new module, at the buyers expense. If the old module is not received after 30 days, the customer will be invoiced. The buyer is responsible for installing the replacement/repaired module in the transmitter.
5. In the event that a "Part" fails during the warranty period and causes damage to a subassembly which cannot be readily repaired in the field, the entire subassembly so damaged may be returned to Nautel for repair. The repairs will be made without charge to the Buyer.
6. Written authorization must be obtained before returning any equipment or goods for any reason. Equipment or goods returned under this warranty shall be delivered to Nautel's premises at the Buyer's expense. Where no-charge warranty replacements or repairs are provided under items 2, 3, 4, or 5, Nautel will pay that part of the shipping costs incurred in returning the part/assembly to the Buyer. Note: the Buyer is responsible for any and all import fees, duties or taxes.

7. Nautel does not warrant or guarantee, and will not be liable for:
 - a. defects or failures caused in whole or in part by abuse, misuse, unauthorized repair attempts, unauthorized alteration or modification of the equipment;
 - b. equipment built to customer specifications that is later found not to meet customer needs or expectation;
 - c. performance of equipment when it is used in combination with other equipment not purchased, specified, or approved by Nautel;
 - d. damages and performance limitations due to outside forces such as lightning, excessive heat or cold, excessive ac surges or high corrosive environments;
 - e. changes made by personnel other than Nautel authorized personnel, including charges incurred; and
 - f. for any costs for labor performed by the customer without Nautel's prior written approval.
8. Nautel does not warrant that software:
 - a. is free of errors, bugs or defects;
 - b. will be compatible with third party software;
 - c. results, output or data provided through or generated by the software are accurate, complete, or reliable; and
 - d. errors found will be corrected.
9. Nautel shall have the right and shall be provided full access to investigate whether failures have been caused by factors beyond its control.
10. In no event shall Nautel be liable for any consequential damages arising from the use of this equipment.
11. This warranty is in lieu of all other express warranties of Nautel, whether express or implied, and Nautel does not assume, nor is any other person authorized to assume on Nautel's behalf, any other obligation or liability.
12. Third party items ordered, the guarantee/warranty of these items will be from the manufacturer of these items. Exercise of such warranty shall be between the Buyer and the third party provider.
13. Nautel provides telephone and email support for its products for the life of the product at no charge. After the warranty period, parts and on-site support for the equipment are offered at a rate to be determined upon request.

Technical Assistance

Nautel's field service department provides telephone technical assistance on a 24 hour, seven days a week basis. Requests by other media (fax or e-mail) will be responded to the next working day if received after Nautel's normal working hours. Contact the appropriate field service centre:

Nautel Limited
10089 Peggy's Cove Road
Hackett's Cove, NS Canada B3Z 3J4
Phone: +1.902.823.3900 or
Toll Free: +1.877.6NAUTEL (6628835) (Canada & USA only)
Fax: +1.902.823.3183

Nautel Inc.
201 Target Industrial Circle
Bangor, Maine USA 04401
Phone: +1.207.947.8200
Fax: +1.207.947.3693

Customer Service (24 hour support)
+1.877.628.8353 (Canada & USA only)

+1.902.823.5100 (International)

Email: support@nautel.com
Web: www.nautel.com

About This Manual

Technical Support

Nautel offers technical support to customers over the Internet and by telephone. Nautel's customer support team will answer your questions and work with you to identify and resolve problems.

For 24-hour technical support, call toll free at 1.877.628.8353 (in USA and Canada only) or call 1.902.823.5100 (international) or find us on the Internet at <http://www.nautel.com>.

About Safety

All Nautel transmitters are designed to meet the requirements of EN60215, Safety Requirements for Radio Transmitters. The philosophy of EN60215 is that the removal of any cover or panel that can only be opened using a tool is a maintenance activity, and that any person performing a maintenance activity is expected to be trained for that activity. Under EN60215, it is assumed that trained personnel will be knowledgeable and will take precautions such as removing all power to the transmitter before accessing its components.

Electrical Hazards

To remove power from the transmitter, switch off and lock out the ac power. Some transmitter models will have amber LEDs at the bottom rear of the cabinet that glow to remind anyone who has not turned off the power that the system is live and serious danger is present.

DANGER - HIGH VOLTAGE



Indicates dangerous voltage (in excess of 72 volts), capable of causing a fatal electrical shock, are present on or near parts bearing this label.

WARNING: It is not enough to switch off RF power. The power line is still connected. Disconnect and lock out the upstream supply before servicing.

Mount the transmitter ac power disconnect switch/breaker close to the transmitter so that it can be reached quickly in an emergency. Clearly label the switch/breaker (e.g., EMERGENCY SWITCH).

After turning off the power, always perform a measurement to confirm that the power is off before touching anything within the transmitter. If the wrong breaker was opened, the equipment will be live.

WARNING: Do not use an ordinary multimeter to check for voltage, since it may have been left inadvertently on the AMP (A) range, triggering a short and an arc blast that could result in severe burns and even death.

Use only a non-contact voltage probe or a safety voltmeter (available from vendors such as Fluke, Ideal, and Teagam).

Use a proper lockout procedure to ensure that another worker cannot accidentally reapply power while you are performing maintenance on any part of the transmitter or site.

Lightning Hazards

Before opening the transmitter and touching internal parts, remove and solidly ground the antenna connection.

WARNING: It is not enough to ground the antenna terminal with the antenna still connected. Even a small impedance in the ground strap will result in lethal voltages during a lightning strike.

RF Hazards

A serious RF hazard and very high voltages exist in the vicinity of the antenna and its networks during normal operations.

Toxic Hazards

There may be devices used in this equipment containing beryllium oxide ceramic, which is non-hazardous during normal device operation and under normal device failure conditions. These devices are specifically identified with "(BeO)" in the Description column of the Troubleshooting Manual's parts list(s).

Do not cut, crush or grind devices because the resulting dust may be hazardous if inhaled. Unserviceable devices should be disposed of as harmful waste.

Other Hazards

Ensure that appropriate fire alarms and fire extinguishers are available. Extinguishers must be suitable for use on electrical fires.

Many other site safety risks exist. It is beyond the scope of this manual to identify all the risks and procedures.

Safety Precautions

This section provides very important information about protecting the safety of personnel and equipment:

- [Personal Safety](#)
- [Site Safety - see page xxii](#)
- [Equipment Safety - see page xxiv](#)

Personal Safety

Training

The training of any personnel who will have physical access to the site or the transmitter is very important. Personnel must be familiar with the transmitter, so that they can avoid physical danger, and be aware of hazards to themselves and the equipment.

Nautel offers a number of training courses covering the basic fundamentals of RF systems and transmitters, and the operation and maintenance of the transmitter. For more information about available courses and schedules, go to the Nautel website at <http://www.nautel.com/Training.aspx>, or ask your Nautel sales representative.

Site Orientation

When you give personnel access to the transmitter site (e.g., hiring new personnel, or giving access keys to personnel), perform a site orientation to ensure that they are familiar with the site, on-site procedures, and on-site hazards. Cover the following topics:

- Securing the site (locking doors and fences) to prevent unauthorized access
- How and when to call for technical support or emergency assistance
- Areas of the site and pieces of equipment that are off limits

Voltage Awareness

Ensure that all personnel that are able to access areas with high voltage circuits or high field strengths are aware of the hazards associated with high voltage. Cover the following topics:

- High voltage or high field strength areas where caution is required
- Physical risks of electric shock
- Risks for personnel with pacemakers or other medical implants
- Induced voltages in high field strength areas
- On-site risks during thunderstorms and lightning strikes
- Operation of safety interlocks (if installed)

First Aid

Nautel does not offer first aid training, since the hazards associated with high voltage and RF energy are not specific to the transmitter. However, the customer should provide first aid training to all personnel who have access to the transmitter site. First aid training should include CPR, care of burns, artificial respiration, and defibrillation if specific equipment is available on-site.

Site Safety

Controlling Access

Transmitters and antennas generate and carry dangerous voltages that can be harmful or fatal. It is very important that you control access to the site and its equipment. To secure your transmitter site, use:

- Locking steel or security doors to prevent casual access
- A perimeter fence to keep trespassers away from the antenna system and feedline
- "No Trespassing" signs
- An alarm system

Marking Hazards

Place warning signs close to any hazardous areas or systems (e.g., the feedline or the antenna system). Make the signs large enough that they cannot be missed. Provide signage in all languages used in the region. These signs are intended not only for authorized personnel, but also for emergency responders or accidental trespassers.

Qualifying Site Personnel

Make sure that personnel who have access to the site are qualified to work around electronics and high voltage systems.

Ac Power Protection

You should take steps to protect equipment from surges (over-voltage spikes) on the ac power lines. Surges may occur during thunderstorms, or because of malfunctions in the electrical distribution grid. Surge suppressors and ac power conditioners can prevent serious damage to your on-site equipment, including the transmitter.

RF Protection

Transmitters and their antenna systems create intense radio frequency fields at the transmitter site, particularly near the feedline, antenna and tower. At some sites, these fields may cause biological effects, including the heating of body tissues. Intense fields can also create dangerous high voltages on ungrounded, conductive surfaces and objects. At certain points where high voltage conductors come close to grounded conductors (e.g., at feedline junctions or on the tower), dangerous electrical arcing or overs can occur. It is very important that you take the following steps to prevent damage to equipment or personnel due to RF fields:

- Use safety interlocks to de-energize transmitters if personnel open doors or panels accessing high field areas
- Place warning signs in any locations where high fields can occur
- Train personnel about the short-term and long-term hazards of RF radiation
- Physically block access to the area around the antenna system, feedline and tower
- Ground all exposed conductive surfaces or objects in high field areas

The RF connection to the transmitter output can be a serious safety hazard. Connect a suitable antenna simulator during installation and commissioning. It is recommended that a switch be used to automatically connect the transmitter to the antenna system without human contact with the transmitting conductors.

Safety Interlocks

The transmitter contains an electrical interlock, which is an external circuit that turns off the RF output if any of its switches are opened.

Ac Disconnect Switch

Safe operation of the transmitter requires an ac disconnect switch. Lock the ac disconnect switch in the disconnected (open) position during the installation process.

Equipment Safety

Electrostatic Protection

The transmitter's systems are very rugged and resistant to damage. However, it is possible for damage to occur because of high voltage electrostatic discharges during servicing. Train all service personnel to ground themselves to bleed off any static charge before opening the transmitter or touching any exposed components. Provide a grounding wand or known ground (e.g., a grounded metal table) that personnel can use to discharge themselves.

Surge Protection

Surge protection is recommended for your entire site. However, even if you do not use a surge protector on the service entrance to the site, you should install a surge protector in the transmitter's ac power feed to prevent over-voltage from entering the transmitter.

Lightning Protection

The transmitter is designed to resist lightning strike damage. However, intense or repeated strikes could damage the transmitter. We recommend that you install lightning suppression on the antenna, tower and feedline to reduce the effect of lightning strikes on the transmitter itself (and to protect the rest of your site equipment and your personnel). For detailed information about lightning protection, see the Nautel Site Preparation Manual, available from your Nautel sales agent, or online from the Nautel website.

Physical Protection

Consider physical hazards to equipment at your site, including the transmitter. Ensure that equipment is protected from weather (e.g., rain or flooding), even during extreme weather events. Place equipment so that it is not in the path of swinging doors or high-traffic areas. Do not allow wheeled items like office chairs or tables with wheels in the transmitter room, as these may damage equipment if accidentally pushed or knocked over. Do not place the transmitter under water pipes, drains, or sprinklers. Keep any equipment that generates heat, like the transmitter, away from flammable materials like ceiling panels, cubicle dividers, and curtains.

Earthquake Protection

If the transmitter site is in a region that experiences any noticeable earthquake activity, take steps to prevent the transmitter from shifting or rocking during an earthquake. Even during minor earthquakes, rocking or movement of the transmitter is likely to damage the feedline connection, and could even cause a catastrophic failure of the ac power feed into the transmitter. During larger earthquakes, the weight of the transmitter chassis could be hazardous to nearby equipment or personnel.

SECTION 1: GENERAL INFORMATION

Introduction

The VS-TC Transfer Controller can be used in conjunction with two Nautel FM broadcast transmitters that are to be connected in a main-standby configuration (see [Supported Transmitter Configurations, on page 1.3](#)). It controls the on/off status of the transmitters, by controlling their RF mute circuits. It also controls the state of an internal coaxial relay, which routes the RF output of the on-air transmitter to the antenna. It also selects from one of two program input sources.

This manual provides instructions for interfacing the transfer controller to the transmitters and the associated RF coaxial switch.

Topics in this section include:

- [About this Manual](#)
- [Mechanical Description, on page 1.2](#)
- [Technical Summary, on page 1.4](#)

About this Manual

This manual provides information about preparing for the delivery and installation of the transfer controller. This manual is intended for use by field technicians, site managers and installation planners.

Transmitter Manuals

The system also comprises a pair of FM broadcast transmitters that have their own documentation suite. This manual makes reference to the VS150C, VS300 or VX150-VX600 documentation. See the associated manuals for detailed information.

Online Resources

The Nautel website (www.nautel.com) provides useful resources to keep you up to date on your equipment.

NOTE: From the Nautel website's main page, choose the product line that suits your equipment. If you select 'Radio Broadcast Communications' or 'Navigation and Communication', the next page contains a Nautel User's Group (NUG) link.

NAUTEL USER'S GROUP. The website includes a special section that customers can log into in order to access the Nautel customer newsletter, product manuals, frequently asked questions (FAQ), information sheets, and information about field upgrades.

ONLINE DOCUMENTATION. The website's NUG section provides online access to all the documentation for your transmitter system. Documentation is provided in Acrobat (PDF) format. You can use the documentation online or print the sections section that you need.

Mechanical Description

See [Figure 1.1 on page 1-3](#).

Dimensions and Clearances

The VS-TC is contained in a standard 19-inch rack mountable unit and is 3.5 inches (2RU, 7.7 cm) in height and 10.125 inches (25.7 cm) deep. Nautel recommends that you plan for 1RU of air space between the VS-TC and each transmitter if the transmitters are installed in a cabinet..

Weight

The VS-TC weighs 2 kg (4.4 lbs).

Installation

There are two front panel handles and the VS-TC requires no cabinet rail support. It is secured using four front panel screws, located in the panel screw kit (Nautel Part # 198-5025-01) of the ancillary kit.

Cooling

The VS-TC is convection cooled (no fans) and has a removable top cover to allow easy access to internal components for service.

Interfacing

The front panel has push-button switches and LEDs for local control and monitoring, as well as a CONSOLE port for interface to a laptop or PC. All other interconnection and user interface connections are made at the rear of the VS-TC, via various connector types that accept main and backup program inputs (XLR), remote interface connections (D-sub), transmitter interface connections (RJ45) and RF input/output connections (N-type) and interlock connections (2-terminal connector).

Refer to the assembly detail drawings in [SECTION 8: Mechanical Drawings](#) for more detail.

Figure 1.1: VS-TC Transfer Controller

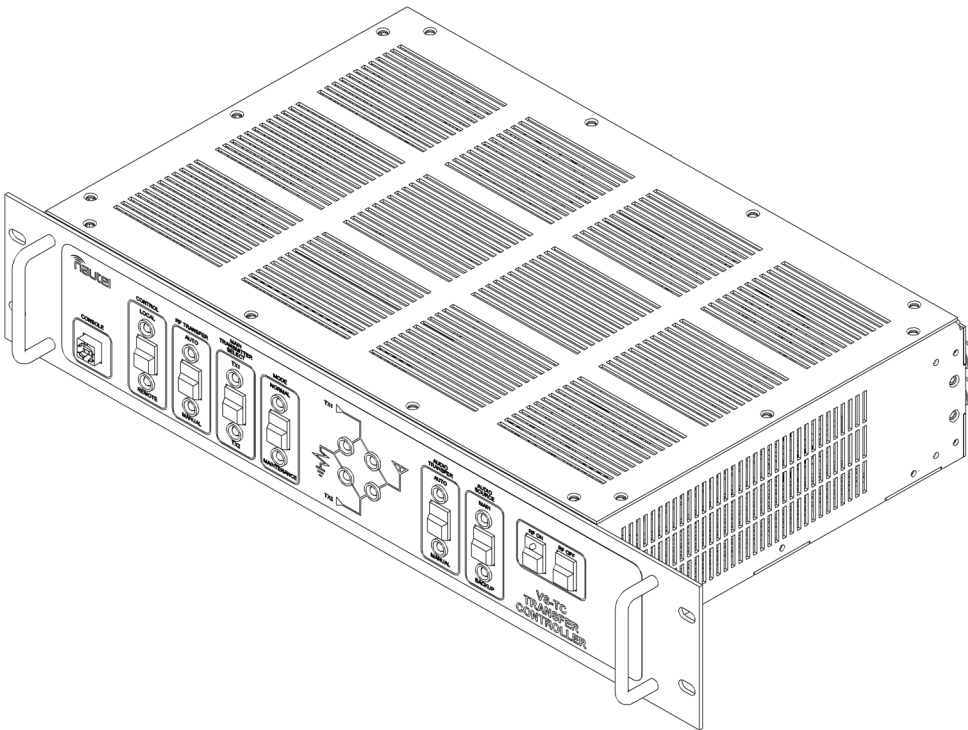

Supported Transmitter Configurations

The following main-standby transmitter configurations are supported by the VS-TC Transfer Controller:

- ❖ VS150C with VS150C
- ❖ VS300 with VS300
- ❖ VX150 to VX600 with VX150 to VX600

NOTE: Each VX series transmitter used in a system configuration also requires a VS-TC to VX serial converter assembly (Nautel Part # 235-5650*).

Technical Summary

Table 1.1 provides a complete technical summary of the VS-TC, including capabilities and specifications.

Table 1.1: Technical Summary

Category	Parameter	Specification Value/Conditions/Comments
GENERAL	Configuration	<p>Provides RF and audio switching logic and remote control interface for dual transmitter system</p> <p>Provides two auto-switching AES inputs for main and backup audio feeds and distribution of selected AES source to two AES outputs</p> <p>Programmable AES switch settings and thresholds via serial interface</p> <p>Front panel controls and status LEDs</p> <p>Integrated four-port coaxial switch with latching self cut-off circuit, position indicators and interlock outputs</p>
CONTROL AND MONITORING	Front Panel Control/ Status	<p>Momentary switches and status LEDs are provided for each of the following:</p> <ul style="list-style-type: none"> ■ CONTROL (LOCAL/REMOTE) ■ RF TRANSFER (AUTO/MANUAL) ■ MAIN TRANSMITTER SELECT (TX1/TX2) ■ MODE (NORMAL /MAINTENANCE) ■ AES TRANSFER (AUTO/MANUAL) ■ AES SOURCE (MAIN/BACKUP) ■ SYSTEM RF ON/OFF <p>Active RF output paths and transmitter operating states are displayed on a front panel LED diagram.</p>
	System Interlock	Provided on 2-terminal connector

Category	Parameter	Specification Value/Conditions/Comments
CONTROL AND MONITORING (continued)	Remote Control/Status	<p>All remote I/O is provided on a female 25-pin D-sub connector.</p> <p>Remote Inputs:</p> <ul style="list-style-type: none"> ■ RF ON ■ RF OFF ■ TX1 TO AIR SELECT ■ TX2 TO AIR SELECT ■ EXT. +15 V IN ■ AUTO RF TRANSFER SELECT ■ AUTO AES TRANSFER SELECT ■ MAIN AES SELECT ■ BACKUP AES SELECT ■ MAINTENANCE MODE SELECT <p>Remote Outputs:</p> <ul style="list-style-type: none"> ■ RF ON STATUS ■ SYSTEM INTERLOCK OPEN ALARM ■ TX1/TX2 TO AIR ■ MAIN/BACKUP AES ■ +15 V DC OUT ■ AUTO RF TRANSFER ENABLED ■ AUTO AES TRANSFER ENABLED ■ MAIN AES ALARM ■ BACKUP AES ALARM ■ MAINTENANCE MODE ENABLED ■ REMOTE CONTROL ENABLED ■ SUMMARY ALARM ■ SWITCH FAULT
RF AND AUDIO SWITCHING	RF Switching Options	<ul style="list-style-type: none"> ■ RF TRANSFER MODE (AUTO/MANUAL) ■ MAIN TRANSMITTER SELECT (TX1/TX2) ■ *MODE (NORMAL/MAINTENANCE) <p>* Activating Maintenance mode enables the standby transmitter for operation into a test load.</p>

NOTE: RF and Audio Switching Options can be configured in local or remote mode. In local, options are set from the front panel switches or via the front panel serial console (USB - Type B connector). In remote, options are set through the remote I/O on the rear panel.

Category	Parameter	Specification Value/Conditions/Comments
RF AND AUDIO SWITCHING (continued)	AES Switching Options	<ul style="list-style-type: none"> ■ AUDIO TRANSFER MODE (AUTO/MANUAL) ■ AUDIO SOURCE (MAIN/BACKUP), MANUAL mode only
	Main Transmitter RF Transfer Settings	<ul style="list-style-type: none"> ■ Low Threshold Level: 10 to 90 % ■ Low Threshold Delay: 0 to 300 s
	Main AES Source Transfer Settings	<ul style="list-style-type: none"> ■ Low Threshold Level: 0 to -60 dBFS ■ Low Threshold Delay: 0 to 300 s ■ Normal Threshold Level: 0 to -60 dBFS ■ Normal Threshold Delay: 0 to 300 s

NOTE: RF and Audio transfer settings are programmable in local mode via the front panel serial console (USB - Type B connector).

POWER SUPPLY	Input Voltage	+24 V dc \pm 10% Redundant +24 V dc supplies provided by VS150C transmitters or by external ac-dc power supplies provided in the ancillary kit
	Power Consumption	3 W maximum
COAXIAL SWITCH (dc to 108 MHz ratings)	Total Input Power	1500 W, at 40°C (104°F), sea level, load VSWR < 1.10:1
	Input Power Derating Factors	<ul style="list-style-type: none"> ■ VSWR of 1.5:1, derate by 0.96 ■ Temperature of 50°C (122°F), derate by 0.95 ■ Altitude of 3000 m (10,000 ft), derate by 0.90
	Input VSWR	< 1.10:1
	Isolation	85 dB minimum (dc to 1 GHz)

Category	Parameter	Specification Value/Conditions/Comments
REAR PANEL CONNECTIONS	Remote Control/Monitoring	One female 25-pin D-sub connector
	System Interlock	2-position screw terminal block
	Transmitter Control/Monitoring	Dual RJ45 connector (serial link from transfer controller to each transmitter)
	Controller Program Port	One female 9-pin D-sub
	+24 V dc Inputs	Dual 2.5 mm x 5.5 mm jacks (redundant)
	Audio	<ul style="list-style-type: none"> ■ AES IN (MAIN): XLR female ■ AES IN (BACKUP): XLR female ■ AES OUT (TX 1): XLR male ■ AES OUT (TX 2): XLR male
	RF Coaxial Switch	Type 'N', female: <ul style="list-style-type: none"> ■ Port 1: Antenna ■ Port 2: TX 2 ■ Port 3: TX 1 ■ Port 4: Dummy Load
ENVIRONMENTAL	Temperature Range	0°C to +50°C (32°F to 122°C)
	Humidity Range	10% to 95% non-condensing
	Altitude	0 m to 3000 m (0 ft to 10,000 ft)
	Cooling Requirements	Convection cooled (no fans)
PHYSICAL	Dimensions	<ul style="list-style-type: none"> ■ W = Standard 19" (48.3 cm) EIA rack [minimum opening of 17.5" (44.5 cm)] ■ H = 2 RU = 3.5" (7.7 cm) ■ D = 1-.125" (25.7 cm)
	Weight	2 kg (4.4 lbs)

SECTION 2: PREPARATION FOR USE & INSTALLATION

This section contains information required to prepare the VS-TC for use and to install it in a user-provided cabinet. Nautel recommends you incorporate all requirements in this section to ensure optimum reliability and performance. Topics include:

- [Preparation for Use](#)
 - [VS-TC Environment Requirements](#)
 - [Electrical Power, on page 2.2](#)
 - [System Interface Connections, on page 2.2](#)
 - [Transmitter Interface Connections, on page 2.3](#)
 - [Remote Control Inputs, on page 2.5](#)
 - [Remote Alarm/Status Outputs, on page 2.9](#)

- [Installation, on page 2.11](#)
 - [Accepting the Shipment, on page 2.11](#)
 - [Installing the VS-TC, on page 2.11](#)
 - [Installing External Control/Monitor Wiring, on page 2.11](#)
 - [Installing Transmitter Interconnect Wiring and Cables, on page 2.11](#)

NOTE: Failure to comply with these recommendations and instructions could void the manufacturer's warranty. Please review Nautel's warranty terms for more information.

Preparation for Use

Prepare the transmitter system site for the VS-TC Transfer Controller prior to delivery and/or installation. Consider the following when preparing to install a VS-TC.

VS-TC Environment Requirements

Address the following environment requirements when preparing to install the VS-TC. See also [Mechanical Description, on page 1.2](#) of this manual for more information.

DIMENSIONS. See Section 1. These dimensions identify space requirements and assist in determining cable lengths and routing, noting most connections are at the rear of the VS-TC.

CLEARANCES. Nautel recommends 1RU of air space between the VS-TC and each transmitter - if they are mounted in the same cabinet (e.g., VS or VX series) - to ensure optimal convection cooling.

AIR FLUSHING. The VS-TC is convection cooled. Cooling air enters/exits through openings in the top, bottom and sides of the VS-TC.

COOLING. The VS-TC's ambient air temperature must not exceed 50°C (122° F) at sea level. Derate 3°C per 500 m or 2°C per 1,000 ft above sea level (to a maximum altitude of 3,000 m or 10,000 ft.)

HEATING. Control the VS-TC's environment to ensure its ambient temperature does not drop below 0°C (32° F).

WORK AREA. Nautel recommends you provide a suitable work area near the VS-TC to allow bench adjustment and repair.

Electrical Power

The VS-TC can operate from an external dc source [24 ± 4 V (200 mA capable)] applied to either +24Vdc IN connectors on the rear panel. Power consumption is typically 3 W. When operating in a main-standby VS150C system, the VS150C transmitters provide dc power to the VS-TC. When operating standalone or in a main-standby VS300 system, ac-dc power supplies (Nautel Part # **UG116**, provided in the ancillary kit) provides power for the VS-TC.

System Interface Connections

The VS-TC interfaces with a the main-standby system's antenna, dummy load, system interlock, remote control system and AES audio sources. All connections are at the rear of the VS-TC (see [VS-TC Connections](#), on page 2.13).

RF CONNECTIONS. The VS-TC contains an RF coaxial transfer switch that routes the appropriate transmitter's RF output to either the antenna system or the dummy load. RF connections for the antenna and dummy load are made to N-type connectors [ANTENNA (port 1) and DUMMY LOAD (port 4)].

- It is recommended that the antenna system meets (as a minimum) the standards specified in EIA Standard TR-101-A, paragraph 8(b) with a normal impedance of $50 \pm j0$ ohms at the carrier frequency. The transmitter will produce rated power while operating with a maximum reflected power of 4% of the rated transmitter power, which is equivalent to a 1.5:1 VSWR. See the VS150C transmitter manual's pre-installation information for more antenna system requirements. The user must provide a suitably rated coaxial cable between the VS-TC and the antenna system.
- If Nautel does not provide a dummy (test) load, the user must provide a suitably rated precision, 50-ohm resistive load for the main-standby transmitter system. The load will act as the test load for the standby transmitter, allowing maintenance and testing without interrupting the operation of the on-air transmitter. The user must provide a suitably rated coaxial cable between the VS-TC and the dummy load.

SYSTEM INTERLOCK CONNECTIONS. The external system interlock must present a short circuit (low impedance) between terminals 1 and 2 of the SYSTEM INTERLOCK (A1J4) connector on the VS-TC's rear panel when the interlock circuit is intact and it is safe to enable the RF output. It must present an open circuit when an external system interlock switch has been activated and the RF output needs to be inhibited. Any number of serial interlock switches may be installed, provided an open circuit is presented if any interlock switch is activated. A two-pole mini-plug (Nautel Part # JU32) is provided to facilitate this connection. The interlock circuit requires a +15 V dc supply on A1J5-5 (EXT +15V IN). A +15 V output is available on pin 17 of the REMOTE I/O (A1J5) connector. If operating without a remote control system, connect a jumper between pins pin 17 (+15 V out) of the REMOTE I/O (A1J5) connector and pin 5 (+15 V in). The ancillary kit contains a 25-pin D-sub connector (Nautel Part # 230-5025) specifically designed for this purpose.

AES AUDIO CONNECTIONS. The VS-TC accepts main and backup AES audio sources for distribution to the VS transmitters. AES audio inputs are made to the AES IN XLR connectors [MAIN (A1J6) and BACKUP (A1J7)].

SERIAL CONVERTER CONNECTIONS (VX TRANSMITTERS ONLY). Transmitter systems that use one or more VX150 to VX600 transmitters must incorporate the VS-TC to VX serial converter assembly (Nautel Part # 235-5650*) - provided for each VX transmitter. This assembly converts the RS422 serial communication protocol on the VS-TC to the RS485 serial communication protocol on the VX transmitter. Connections are made to the appropriate XMTR LINK connector(s) on the VS-TC and the VX transmitter.

Transmitter Interface Connections

The VS-TC interfaces with a variety of analog and digital signals from the two system transmitters. All connections are at the rear of the VS-TC (see [VS-TC Connections](#), on page 2.13) and the associated transmitters:

- ❖ For VS150 transmitters, see [VS150C System Interconnections](#), on page 2.14
- ❖ For VS300 transmitters, see [VS300 System Interconnections](#), on page 2.15
- ❖ For VX150 to VX600 transmitters, see [VX150 to VX600 System Interconnections](#), on page 2.16

NOTE: In the main-standby FM system the upper transmitter is referred to as Transmitter 1 or TX1 and the lower transmitter as Transmitter 2 or TX2.

XMTR LINK (SERIAL COMMUNICATION). The VS-TC communicates with each transmitter via a serial bus connection. This interface provides control and status information from each transmitter using Tx Data, Rx Data and ground lines. Serial connections are made to the XMTR LINK RJ45 connectors [TX1 (A1J3A) and TX2 (A1J3B)]. When VX150 to VX600 transmitters are used, a VS-TC to VX serial converter assembly (Nautel Part # 235-5650*, one per VX transmitter) is required between the VS-TC and each VX transmitter.

RF CONNECTIONS. The VS-TC contains an RF coaxial transfer switch that routes the appropriate transmitter's RF output to either the antenna system or the dummy load. RF connections for the transmitters are made to N-type connectors [TX1 (port 3) and TX2 (port 2)].

AES AUDIO CONNECTIONS. The VS-TC accepts main and backup AES audio sources and distributes the active source to both transmitters. AES audio connections are made to the AES OUT XLR connectors [TX1 (A1J8) and TX2 (A1J9)].

+24 V Dc SUPPLY. The VS-TC requires a 24 V dc power source as its main source of power. In a VS150C main-standby system, connections are made from each VS150C to the +24Vdc IN connectors [A (A1J1) and B (A1J2)]. In a VS300 or VX150-VX600 main-standby system, connections are made from external ac power sources and two +24 V dc supplies (Nautel Part # UG116). Only one +24 V dc supply is required by the VS-TC. To allow standalone operation without a VS or VX transmitter, the VS-TC can receive its power from an external ac power source by using +24 V dc supply (Nautel Part # UG116) and ac line cord (Nautel Part # JN25). The ancillary kit contains two each of UG116 and JN25 to connect the 24 V dc power supplies to external ac power sources (between 90 to 264 V ac).

Remote Control Inputs

When remote control is enabled via the front panel's CONTROL switch, you can control the main-standby system from a remote location using discrete wiring connections made to the REMOTE I/O (A1J5) 25-pin, D-sub connector on the rear of the VS-TC.

With the exception of controls that affect the operation of the transmitter system, the remote control inputs identified in the VS transmitter manual's pre-installation section are still applicable. A complete, independent set of remote controls can be used for each transmitter.

External Switching Circuit Requirements

External control circuits are interfaced to the VS-TC through opto-couplers on the transfer control PWB (A1A1). The opto-couplers effectively buffer/isolate the external circuits and prevent any unwanted transients from affecting system operation. These opto-couplers only have influence when REMOTE control is selected on the VS-TC's front panel.

The switching circuits for the remotely controlled functions must be the equivalent of a normally open (momentary) switch. The switches must be configured to operate as a single-ended input using the transfer controller's 15 V dc as the source (see [Figure 2.1](#)) or as a differential input using an external dc power supply (12 - 18 V) (see [Figure 2.2 on page 2-6](#)).

Inputs are toggled between states by an active pulse unless otherwise noted. To ensure proper operation, the duration of the active pulse should be a minimum of 250 ms.

OPTION 1 - SINGLE ENDED INPUT (INTERNAL DC SUPPLY). When you use the transfer controller's 15 V as the source for a control function's opto-coupler, connect pins A1J5-5 to pin A1J5-17.

Figure 2.1: Single-Ended Input Selected

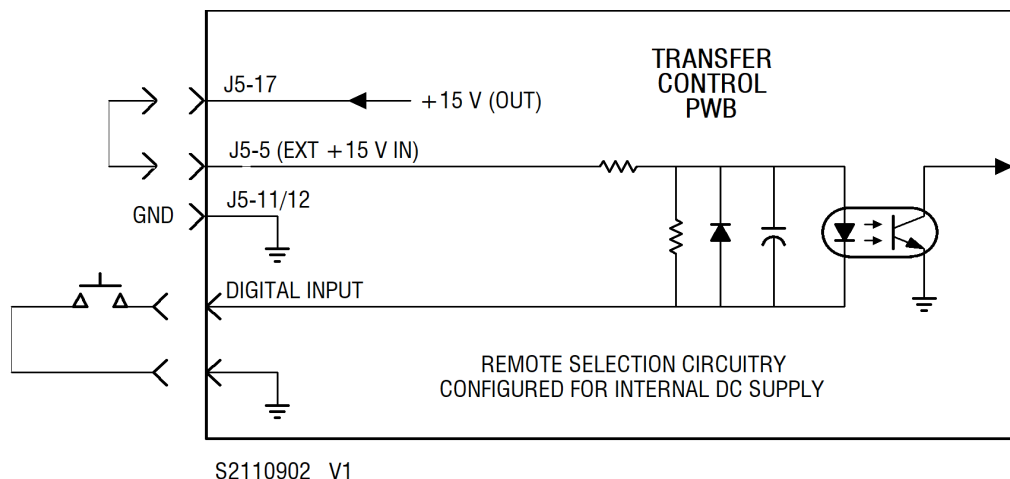

To avoid a ground loop, obtain the ground from the REMOTE I/O connector A1J5 (pins 11 and 12).

OPTION 2 - DIFFERENTIAL INPUT (EXTERNAL DC SUPPLY). When you use an external dc voltage (12 V to 18 V) as the source for a control function's opto-coupler, configure the control function's external switching circuit for a differential input. Configure the REMOTE I/O-A connector for a differential circuit by connecting the external dc supply to A1J5-5.

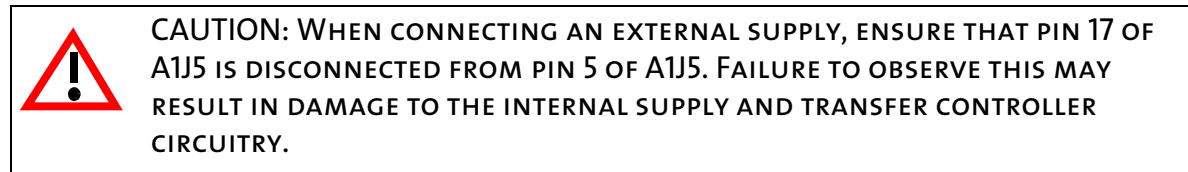
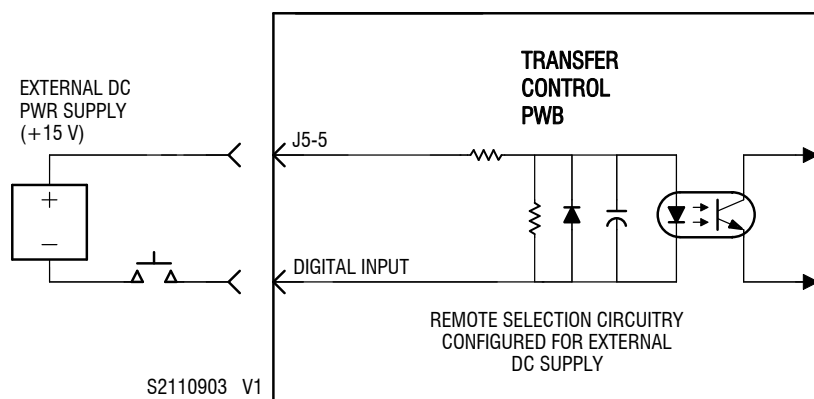

Figure 2.2: Differential Input Selected



The normally open/momentarily closed switch should be located between the dc supply's negative output and the digital input.

Input Connections

Remote control inputs connect to the pins of REMOTE I/O (A1J5) 25-pin male D-sub connector A1J5 on the rear of the transfer controller. See [Table 2.1 on page 2.7](#) to determine the input terminal associated with each digital input.

Table 2.1: Remote Control Inputs

CONTROL INPUT	REMOTE I/O (A1J5) PIN	DESCRIPTION
RF On	1	Asserting this input (0 V) enables the RF output of the transmitter being routed to the antenna system. The front panel's RF ON integral LED will be on (green).
RF Off	2	Asserting this input (0 V) disables the RF output of the transmitter being routed to the antenna system. The front panel's RF ON integral LED will be off. When MAINTENANCE mode is activated, asserting this input will also deactivate MAINTENANCE mode, and disable the RF output of the transmitter being routed to the dummy load.
TX1 to Air	3	Asserting this input (0 V) selects TX1 as the main transmitter. The front panel's MAIN TRANSMITTER SELECT - TX1 LED will be on (green). This will also force the system into MANUAL RF TRANSFER mode and deactivate MAINTENANCE mode.
TX2 to Air	4	Asserting this input (0 V) selects TX2 as the main transmitter. The front panel's MAIN TRANSMITTER SELECT - TX2 LED will be on (green). This will also force the system into MANUAL RF TRANSFER mode and deactivate MAINTENANCE mode.
Ext +15 V in	5	User provided. Provides the dc power source for all remote control input circuits. The user can connect this pin to the +15 V output on A1J5-17.
Auto RF Transfer Select	6	Asserting this input (0 V) sets the RF transfer mode to AUTO. The front panel's RF TRANSFER - AUTO LED will be on (green). The transmitter selected as MAIN will be routed to the antenna, if it was not previously. When MAINTENANCE mode is activated, asserting this input will also deactivate MAINTENANCE mode, and disable the RF output of the transmitter being routed to the dummy load.
Auto AES Transfer Select	7	Asserting this input (0 V) sets the audio transfer mode to AUTO. The front panel's AUDIO TRANSFER - AUTO LED will be on (green). While this control input is asserted, the AUDIO TRANSFER and AUDIO SOURCE front panel buttons and XMTR LINK commands will have no effect.
Main AES Select	8	Asserting this input (0 V) sets the audio source to MAIN. The front panel's AUDIO SOURCE - MAIN LED will be on (green). This will also force the system into MANUAL AUDIO TRANSFER mode.

Table 2.1: Remote Control Inputs

CONTROL INPUT	REMOTE I/O (A1J5) PIN	DESCRIPTION
Backup AES Select	9	Asserting this input (0 V) sets the audio source to BACKUP. The front panel's AUDIO SOURCE - BACKUP LED will be on (green). This will also force the system into MANUAL AUDIO TRANSFER mode.
Maintenance Mode Select	10	Asserting this input (0 V) sets the maintenance mode to MAINTENANCE (i.e., enabled). The front panel's MODE - MAINTENANCE LED will be on (green) and the RF output of the transmitter being routed to the dummy load will be enabled. This will also de-activate AUTO RF TRANSFER mode.
Ground	11, 12	Use as required for connection of external dc power supply or for input activation.

Conflicting Remote Control Inputs

If more than one remote control input from the RF transfer group of inputs (TX1 to Air, TX2 to Air, Auto RF Transfer Select or Maintenance Mode Select) are asserted simultaneously, no action will be taken.

If more than one remote control input from the AES transfer group of inputs (Main AES Select, Backup AES Select or Auto AES Transfer Select) are asserted simultaneously, no action will be taken.

If both RF ON and RF OFF remote control inputs are asserted simultaneously, the RF OFF input will have priority.

Remote Alarm/Status Outputs

Outputs that indicate stress thresholds for critical parameters have been exceeded or the status of operator controlled circuits are available on pins of the REMOTE I/O (A1J5) 25-pin, D-sub connector on the rear of the VS-TC.

- A switching device for each output provides a negative logic (current-sink-to-ground) output when the output is asserted and an open collector when it is not asserted. Each monitoring circuit must present impedance between the switching device and a positive dc voltage source (< 24 V) that results in a current flow of not more than 25 mA.
- A +15 V dc power supply is available at A1J5 pin 17. If an external dc power source is used, it must not exceed 24 V and its return must be connected to a ground pin of A1J5 (11 or 12).
- All alarm and status outputs are protected against transients and over-voltage by 39 V zener diodes.
- [Table 2.2](#) provides detailed information for the status and alarm outputs on the REMOTE I/O (A1J5) connector.

Table 2.2: Remote Alarm and Status Outputs

ALARM OR STATUS OUTPUT	REMOTE I/O (A1J5) PIN	DESCRIPTION
RF On Status	13	When RF ON has been selected, this output will be a current-sink-to-ground (0 V). The output is open circuit when the system is in an RF OFF state.
System Intlk Open Alarm	14	When the external system interlock is open circuit (i.e., not safe to enable system RF), this output will be a current-sink-to-ground (0 V). The output is open circuit when the external system interlock is intact (i.e., safe to enable system RF).
TX1/TX2 to Air Status	15	When TX1 is being routed to the antenna system, this output will be open circuit. When TX2 is being routed to the antenna system, this output will be a current-sink-to-ground (0 V).
Main/Backup AES Select Status	16	When the MAIN audio source is selected, this output will be open circuit. When the BACKUP audio source is selected, this output will be a current-sink-to-ground (0 V).
+15 V Dc Out	17	+15 V dc power supply provided for external monitoring equipment. The supply is protected by a 125 mA PTC thermistor.

Table 2.2: Remote Alarm and Status Outputs

ALARM OR STATUS OUTPUT	REMOTE I/O (A1J5) PIN	DESCRIPTION
Auto RF Transfer Enabled Status	18	When the system is in automatic RF transfer mode, this output will be a current-sink-to-ground (0 V). The output is open circuit when the system is in manual RF transfer mode.
Auto AES Transfer Enabled Status	19	When the system is in automatic AES transfer mode, this output will be a current-sink-to-ground (0 V). The output is open circuit when the system is in manual AES transfer mode.
Main AES Alarm	20	When the main AES audio level is less than the programmed threshold for longer than the programmed delay period, this output will be a current-sink-to-ground (0 V). The output is open circuit when the main AES audio level is acceptable.
Backup AES Alarm	21	When the backup AES audio level is less than the programmed threshold for longer than the programmed delay period, this output will be a current-sink-to-ground (0 V). The output is open circuit when the backup AES audio level is acceptable.
Maintenance Mode Enabled Status	22	When the system is in maintenance mode (i.e., the transmitter being routed to the dummy load is enabled), this output will be a current-sink-to-ground (0 V). The output is open circuit when the system is in normal mode (i.e., the transmitter being routed to the dummy load is disabled).
Remote Control Enabled Status	23	When the system is in remote enabled mode (i.e., local plus remote), this output will be a current-sink-to-ground (0 V). In this state both local and remote controls are active. In the event of a difference in commands, the remote command takes precedence. The output is open circuit when the system is in local mode only (i.e., all remote controls are disabled).
Summary Alarm	24	When any alarm is occurring, including either of the associated VS transmitters, this output will be a current-sink-to-ground (0 V). The output is open circuit when no alarms are occurring.
Switch Fault	25	When the position of the RF coaxial transfer switch does not agree with the selected state, this output will be a current-sink-to-ground (0 V). The output is open circuit when the RF coaxial transfer switch is in the desired RF routing position.

Installation

Upon delivery of the VS-TC, observe and complete the following:

Accepting the Shipment

Inspect all shipments for transit damage prior to acceptance.

Installing the VS-TC

Install the VS-TC in its intended cabinet or enclosure, in close proximity to the transmitters (if applicable), and secure it using four front panel screws. Allow 1 RU (1.75 inches) of clearance above and below each unit in the cabinet to ensure optimal convection cooling

Installing External Control/Monitor Wiring

Connect wiring originating from the remote control/monitoring devices to terminating points on the REMOTE I/O connector (A1J5) as follows:

NOTE: The [Remote Control Inputs](#), on page 2.5 and [Remote Alarm/Status Outputs](#), on page 2.9 terminate on the REMOTE I/O connector (A1J5) on the rear of the VS-TC. Refer to [VS-TC Connections](#), on page 2.13 to locate the connector. Refer to [Table 2.1 on page 2.7](#) and [Table 2.2 on page 2.9](#) for pin assignments.

- The REMOTE I/O mating connector (Nautel Part # JS31), provided in the ancillary kit, accepts solder connections. Limit wire size to 22 AWG.

Installing Transmitter Interconnect Wiring and Cables

Wiring that interconnects the VS-TC and its associated VS transmitters is supplied with the transmitter system. These connections were described in [Transmitter Interface Connections](#), on page 2.3. Locate these cables and connect them. See [VS-TC Connections](#), on page 2.13, [VS150C System Interconnections](#), on page 2.14, [VS300 System Interconnections](#), on page 2.15, [VX150 to VX600 System Interconnections](#), on page 2.16, and the associated transmitter manual as required.

If VX150 to VX600 transmitters are used in the transmitter system, a VS-TC to VX serial converter assembly (Nautel Part # 235-5650*) is required, one per transmitter. These will be supplied with the transmitter system. It connects between the XMTR LINK ports of the VS-TC and each VX150 to VX600 transmitter. See [VX150 to VX600 System Interconnections](#), on page 2.16 and the VX transmitter manual as required.

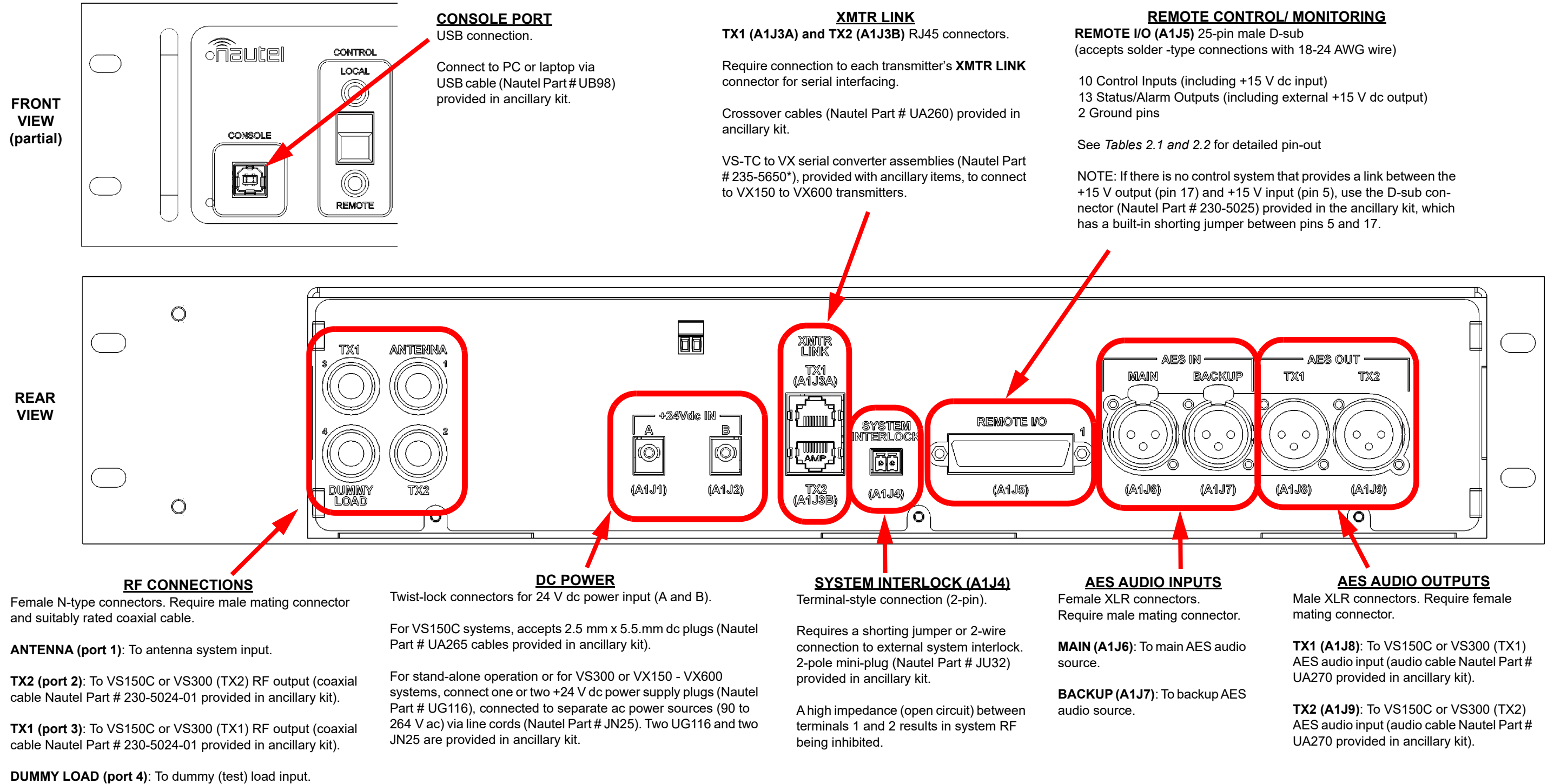
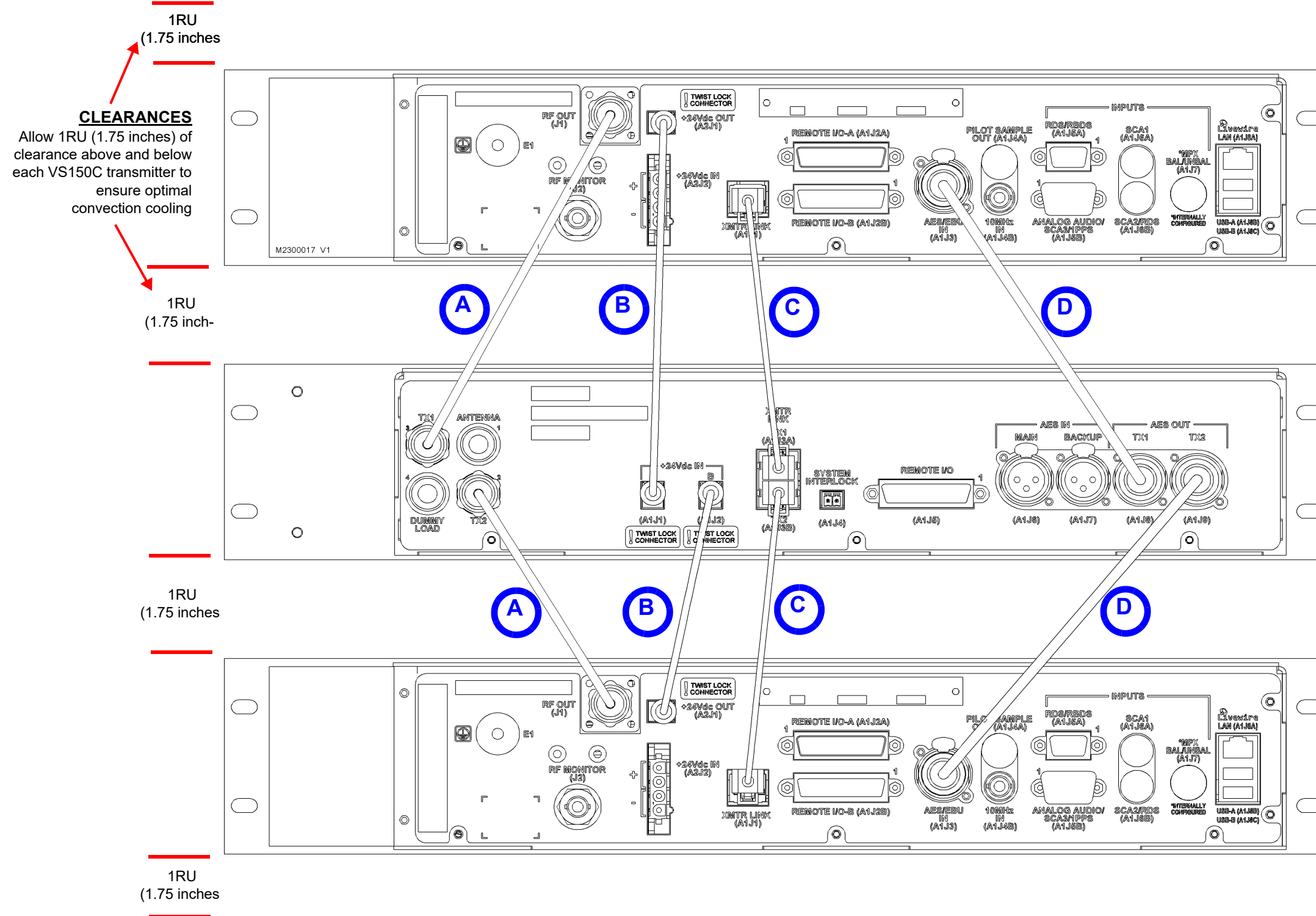

Figure 2-3: VS-TC Connections



A RF CONNECTIONS
 Connect coaxial cables (Nautel Part # 230-5024-01, from ancillary kit) between VS150C RF OUT connectors and VS-TC's TX1 and TX2 connectors

B +24 V DC CONNECTIONS
 Connect dc plug cables (Nautel Part # UA265, from ancillary kit) between VS-TC's +24Vdc IN - A and B connectors and the VS150C +24Vdc OUT connectors

C XMTR LINK CONNECTIONS
 Connect crossover Cat5 cables (Nautel Part # UA260, from ancillary kit) between VS-TC's XMTR LINK - TX1 and TX2 connectors and the VS150C XMTR LINK connectors

D AUDIO CONNECTIONS
 Connect audio cables (Nautel Part # UA270, from ancillary kit) between VS-TC's AES OUT - TX1 and TX2 connectors and the VS150C AES/EBU IN connectors

Figure 2-4: VS150C System Interconnections

CLEARANCES
 Allow 1RU (1.75 inches) of clearance above and below each unit to ensure optimal convection cooling

1RU
 (1.75 inches)

1RU
 (1.75 inches)

1RU
 (1.75 inches)

1RU
 (1.75 inches)

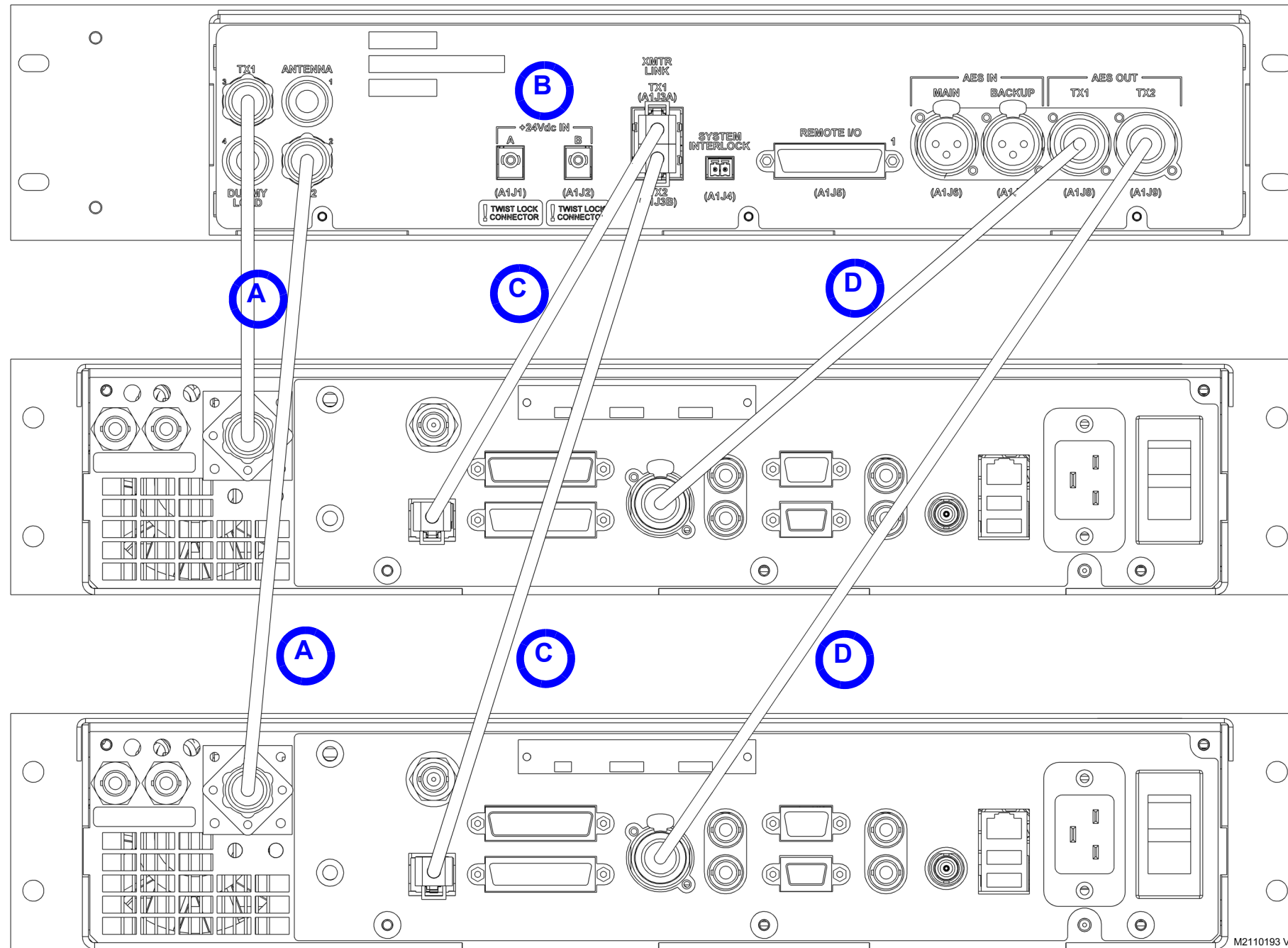

A RF CONNECTIONS
 Connect coaxial cables (Nautel Part # 230-5024-01, from ancillary kit) between VS300 RF OUT connectors and VS-TC's TX1 and TX2 connectors

B +24 V DC CONNECTIONS
 Connect ac-dc power supplies (Nautel Part # UG116, from ancillary kit) and ac line cords (Nautel Part # JN25) between VS-TC's +24Vdc IN - A and B connectors and two separate 90-264 V ac power sources.

C XMTR LINK CONNECTIONS
 Connect crossover Cat5 cables (Nautel Part # UA260, from ancillary kit) between VS-TC's XMTR LINK - TX1 and TX2 connectors and the VS300 XMTR LINK connectors

D AUDIO CONNECTIONS
 Connect audio cables (Nautel Part # UA270, from ancillary kit) between VS-TC's AES OUT - TX1 and TX2 connectors and the VS300 AES/EBU IN connectors

Figure 2-5: VS300 System Interconnections

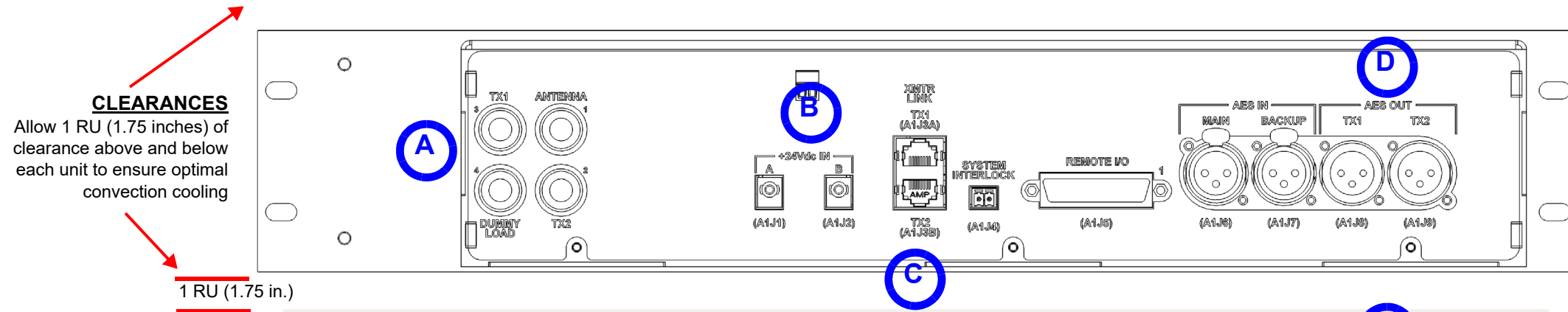

A RF CONNECTIONS
Connect coaxial cables (Nautel Part # 230-5024-01, from ancillary kit) between VX RF OUT connectors and VS-TC's TX1 and TX2 connectors

B +24 V DC CONNECTIONS
Connect ac-dc power supplies (Nautel Part # UG116, from ancillary kit) and ac line cords (Nautel Part # JN25) between VS-TC's +24Vdc IN - A and B connectors and two separate 90-264 V ac power sources.

C XMTR LINK CONNECTIONS
Connect VS-TC to VX serial converter assembly (Nautel Part # 235-5650*), provided for each VX transmitter, between VS-TC-HP's XMTR LINK - TX1 and TX2 connector(s) (W1P1) and the VX XMTR LINK connector(s) (W2P2).

D AUDIO CONNECTIONS
Connect audio cables (Nautel Part # UA270, from ancillary kit) between VS-TC's AES OUT - TX1 and TX2 connectors and the VX AES/EBU IN connectors.

1 RU (1.75 in.)

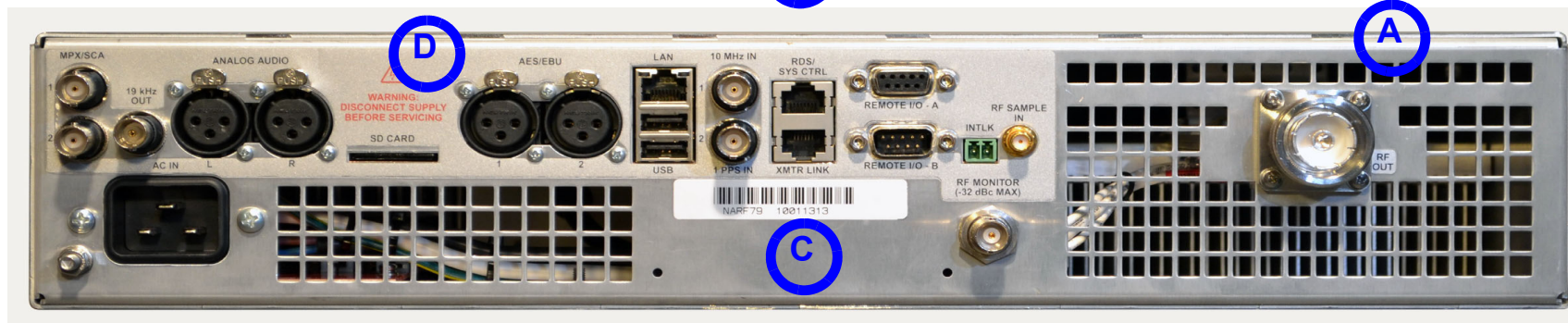

1 RU (1.75 in.)

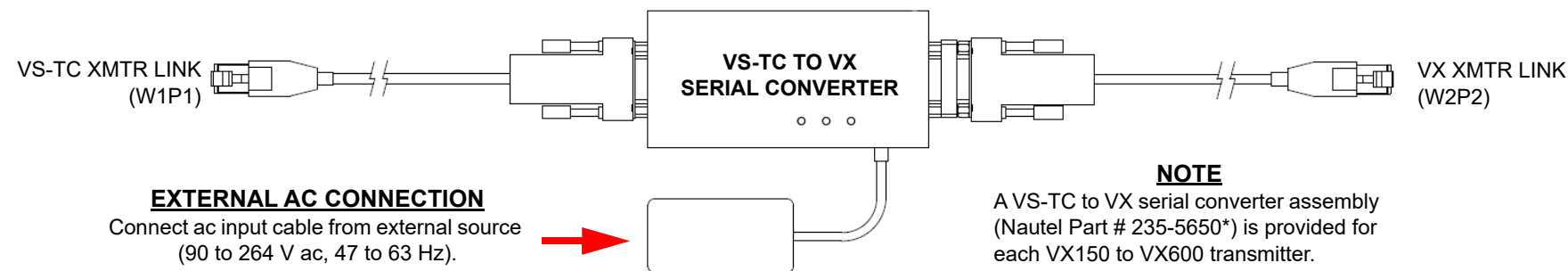

Figure 2-6: VX150 to VX600 System Interconnections

SECTION 3: OPERATING INSTRUCTIONS

This section includes operational information about the VS-TC Transfer Controller, including:

- [Emergency Shutdown](#)
- [External Safety Interlock, on page 3.2](#)
- [Electrostatic Discharge Protection, on page 3.2](#)
- [Controls and Indicators, on page 3.3](#)
- [Local Operation, on page 3.6](#)
- [Remote Operation, on page 3.33](#)
- [Upgrading Firmware, on page 3.49](#)

The information in this section is intended primarily for persons involved in testing or maintenance of the main-standby transmitter system. Refer to the associated transmitter manual for additional operating instructions that pertain to the individual transmitters.

CAUTION! This equipment contains many solid state devices that can be damaged if they are subjected to excessive heat or high voltage transients. Ensure the circuits are not overdriven and are not disconnected from their loads while turned on.

Emergency Shutdown

If an emergency shutdown is necessary, no special precautions are required.

Turn Off RF Output

When the cause of the emergency shutdown is external to the transmitter or is in the RF output portion of the transmitter, opening any external interlock switch will turn off the power produced by the RF power stage.

WARNING! Opening an interlock switch will not remove the ac power source voltage from the transmitter or inhibit any of the internal low voltage dc supplies. If the reason for the shutdown requires all voltages be turned off, proceed directly to [Complete Shutdown, on page 3.2](#).

Complete Shutdown

When the cause of the emergency shutdown dictates the need for a complete shutdown of the transmitter, disconnect (lock out) ac power for each transmitter.

External Safety Interlock

The external electrical interlock circuit is a protection circuit controlled by user determined, serially connected, normally open/held closed interlock switches. It inhibits the RF output when it is not safe to produce RF output.

When all of the external interlock switches are closed and it is safe to produce an RF output, the main transmitter will not indicate an "interlock open" alarm and the operator will have full control of the main transmitter functions.

When any external interlock switch is open, the RF output stage of each transmitter will automatically turn off. Both transmitters will indicate an "interlock open" alarm. It is not possible to enable the RF power stages until all of the external interlock switches are closed.

Electrostatic Discharge Protection

The transmitter system's assemblies contain semiconductor devices that are susceptible to damage from electrostatic discharge (ESD). Observe the following precautions when handling an assembly that contains these devices:

NOTE: Electrostatic energy is produced when two insulating materials are rubbed together. A person wearing rubber-soled shoes, walking across a nylon carpet or a waxed floor can generate an extremely large electrostatic charge. This effect is magnified during periods of low humidity. This high voltage may damage semiconductor devices such as integrated circuits, field-effect transistors, thyristors and Schottky diodes unless adequate precautions are taken.

Discharging of Personnel

Maintainers must be electrically discharged by a suitable ground system (anti-static mats, grounding straps) when removing an assembly from the transmitter and while handling the assembly for maintenance procedures.

Handling/Storage

Place the assembly in an anti-static bag when it is not installed or when it is not being subjected to maintenance procedures. Electronic components should be stored in anti-static materials.

Tools/Test Equipment

Testing and maintenance equipment, including soldering and unsoldering tools, should be suitable for contact with static sensitive semiconductor devices.

Stress Current Protection

Always ensure the static sensitive semiconductor devices are protected from unnecessary stress current. This is achieved by ensuring:

- ❖ Current is not flowing when an electrical connection is broken.
- ❖ Voltages are not present on external control/monitoring circuits when they are connected.

Controls and Indicators

Nautel recommends the operator/maintainer is familiar with the transmitter system's controls and indicators before operating the system and/or attempting to perform fault diagnostics.

VS-TC Front Panel

The front panel (see [Figure 3.1](#)) is the primary local user interface for the VS-TC. See [Table 3.1](#) on [page 3.4](#) for detailed descriptions of the controls and indicators.

NOTE: All of the functionality achieved by using the control and indicators on the VS-TC's front panel is also available using a PC and a terminal program such as PuTTY (see [Using the CONSOLE Port](#), on [page 3.33](#)) connected to the front panel CONSOLE port (see [Using the CONSOLE Port](#), on [page 3.33](#)).

Figure 3.1: VS-TC Front Panel (Partial View) Controls and Indicators

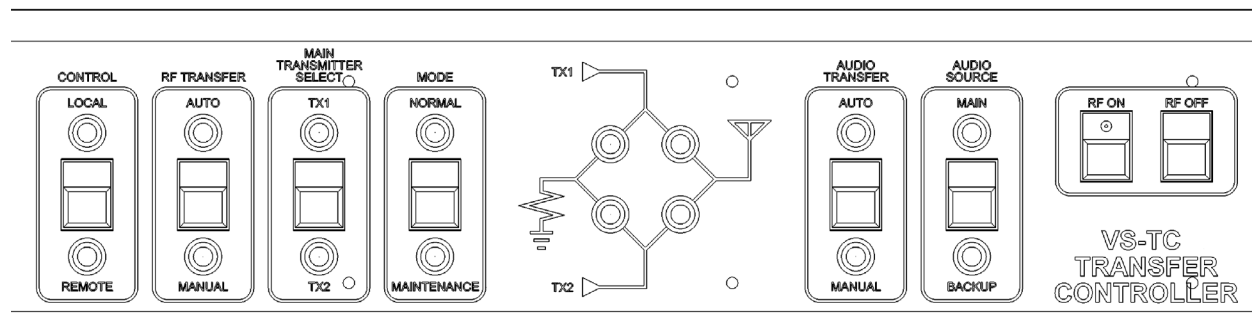

Table 3.1: Front Panel Controls and Indicators

Button or LED Name	Description
CONTROL button LOCAL, REMOTE LEDs	<p>Toggle switch that sets the local/remote control mode for the transmitter system.</p> <p>When only the LOCAL LED is on (green), the system is in local control mode. Commands issued via the front panel switches OR from the CONSOLE port (via a terminal program) OR from the transmitter's UI will have an effect on the transmitter system's operation.</p> <p>When both the LOCAL and REMOTE LEDs are on (green), the system is also enabled for remote control (i.e., local plus remote mode). Commands issued via the REMOTE I/O connector on the rear of the VS-TC will have an effect on the transmitter system's operation. Local controls will also function. In the event that there are conflicting commands between the local and remote interfaces, the remote commands have control.</p>
RF TRANSFER button AUTO, MANUAL LEDs	<p>Toggle switch that selects AUTO (automatic) or MANUAL RF transfer control of the transmitter system. The applicable LED will be on (green) to indicate the selection.</p> <p>When set to AUTO, during normal operation, the transmitter designated as main will operate into the antenna and the standby transmitter will be routed to the test load. If the main transmitter fails or its RF output falls below a preset threshold, a transfer will occur so that the standby transmitter is operating into the antenna and the main transmitter is routed to the test load.</p> <p>NOTE: The standby transmitter must have its RF power stage enabled (RF on) in order for an automatic transfer to occur.</p> <p>When set to MANUAL, the transmitter designated as main will operate into the antenna and the standby transmitter will be routed to the test load. Automatic transfer is disabled. Only manual transfers can be made via the MAIN TRANSMITTER SELECT switch.</p>
MAIN TRANSMITTER SELECT button TX1, TX2 LEDs	<p>Toggle switch that designates transmitter 1 (TX1) or transmitter 2 (TX2) as the main transmitter in the system. During normal operation, the main transmitter is routed to the antenna while the standby transmitter is routed to the test load. The applicable LED will be on (green) to indicate the transmitter that has been selected as the main transmitter.</p>

Button or LED Name	Description
MODE button NORMAL, MAINTENANCE LEDs	<p>Toggle switch that selects the maintenance status of the standby transmitter. The applicable LED will be on (green) to indicate the selection. This function is only applicable when the RF TRANSFER switch is set to MANUAL.</p> <p>When set to MAINTENANCE, the RF output of the transmitter routed to the test load will be enabled, allowing testing or maintenance on the standby transmitter.</p> <p>When set to NORMAL, the RF output of the transmitter routed to the test load will be disabled, inhibiting its RF output.</p>
RF Routing Status LEDs	<p>LEDs that indicate the RF routing status of transmitters A and B to the antenna and test load. The upper LEDs are associated with transmitter 1 (TX1). The lower LEDs are associated with transmitter 2 (TX2). The right-hand LEDs indicate the transmitter routed to the antenna. The left-hand LEDs indicate the transmitter routed to the test load.</p> <p>The LED colour indicates the state of the associated transmitter. Refer to the transmitter's documentation for more detail on the LED colour descriptions.</p>
AUDIO TRANSFER button AUTO, MANUAL LEDs	<p>Toggle switch that selects AUTO (automatic) or MANUAL AES audio transfer control. The applicable LED will be on (green) to indicate the selection.</p> <p>When set to AUTO, the main (primary) AES audio source will be applied to both transmitters. If the main AES audio source fails or its amplitude is below a preset threshold, a transfer will occur so that the backup AES audio is applied to both transmitters. If the main AES audio recovers to an acceptable level, the main AES audio will be restored as the transmitter system's source.</p> <p>Both AES audio sources are monitored in AUTO mode. If the backup audio source has also failed, no automatic transfer from MAIN to BACKUP will occur. If either AUDIO SOURCE switch is set, the AUDIO TRANSFER status will switch to MANUAL.</p> <p>When set to MANUAL, automatic transfer is disabled. Only manual transfers can be made via the AUDIO SOURCE switch.</p>

Button or LED Name	Description
AUDIO SOURCE button MAIN, BACKUP LEDs	<p>Toggle switch that designates the main or backup AES audio source as the active source applied to both transmitters. The applicable LED will be on (green) to indicate the audio source that has been selected as the active AES source.</p> <p>When either AES source is manually selected, the AUDIO TRANSFER status switches to MANUAL.</p>
RF ON button (integral LED)	<p>Push-button switch that enables the RF power stage of the transmitter that is routed to the antenna, assuming other conditions (system interlock, TX link serial communications, RF coaxial transfer relay, etc.) are intact. The integral LED will be on (green) to indicate the RF status is on.</p> <p>In MAINTENANCE mode, pressing the RF ON switch enables both transmitters.</p>
RF OFF button (no LED)	<p>Red push-button switch that disables the RF power stage of the transmitter that is routed to the antenna. The RF ON switch's integral LED will be off to indicate the RF status is off.</p> <p>In the RF off state, the MODE status automatically switches to NORMAL (test load transmitter disabled).</p> <p>In MAINTENANCE mode, pressing the RF OFF switch disables both transmitters.</p>

Local Operation

There are three methods to locally interface with the VS-TC:

- Using the controls and indicators on the VS-TC's front panel, described above.
- Using the front panel UI of either of the associated transmitters.
- Using a terminal program (e.g., PuTTY) on a laptop or PC that is connected to the CONSOLE port on the VS-TC's front panel. See [Using the CONSOLE Port, on page 3.33](#). This method is available in both local and local+remote modes.

For information on operating the system from a remote location (e.g., remote control site), refer to [Remote Operation, on page 3.33](#).

Using the Transmitter's UI

When the associated transmitter is configured to recognize the VS-TC (i.e., the transfer controller feature is enabled), various additional UI menus are enabled on the transmitter UI that allow control and monitoring of the VS-TC.

NOTE: Refer to the associated transmitter's Operations and Maintenance Manual for details on navigating the front panel UI.

VS TRANSMITTERS:

The Transfer Ctrl menu is in the User Settings menu (see [Figure 3.2](#)).

Figure 3.2: User Settings -> Transfer Control Option

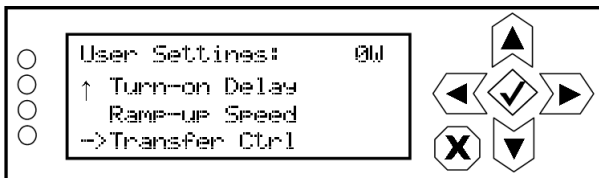

Use the up and down buttons to select Transfer Ctrl. Press the accept (checkmark) button to enter the Transfer Ctrl menu (see [Figure 3.3 on page 3.7](#)).

Figure 3.3: Transfer Control Menu

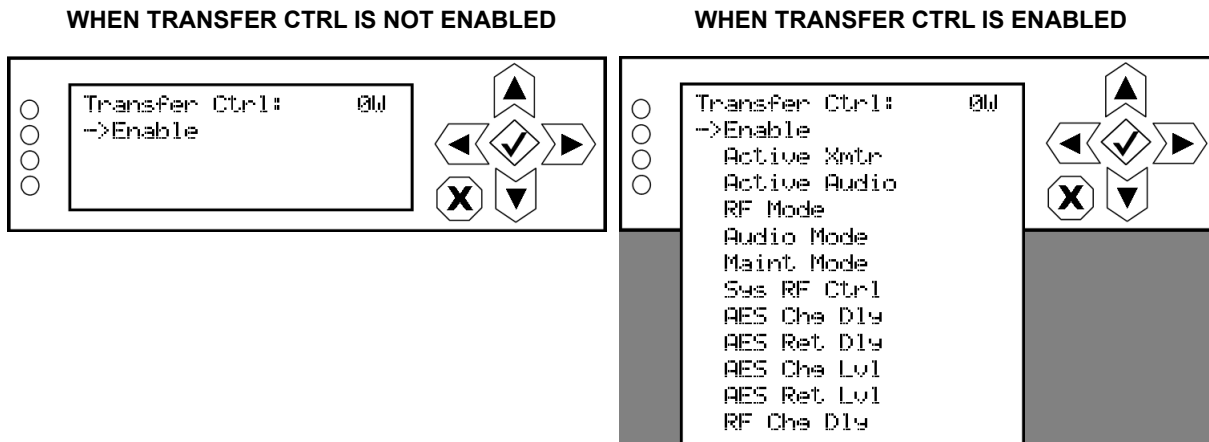

IMPORTANT! In order for RF output to be enabled, Transfer Ctrl must be enabled and the transmitters set to RF ON when the transmitters are connected to the VS-TC.

VX TRANSMITTERS:

The Transfer Control menu is in the Settings -> System menu (see [Figure 3.4](#)).

Figure 3.4: User Settings -> Transfer Control Option (VX)

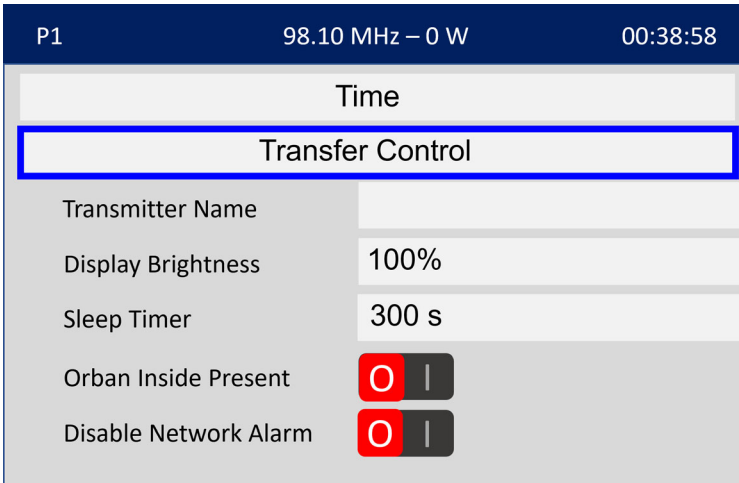

Use the front panel rotary knob to select Transfer Control. Press to enter the Transfer Control menu (see [Figure 3.5](#)).

Figure 3.5: Transfer Control Menu (VX)

WHEN TRANSFER CTRL IS NOT ENABLED



WHEN TRANSFER CTRL IS ENABLED

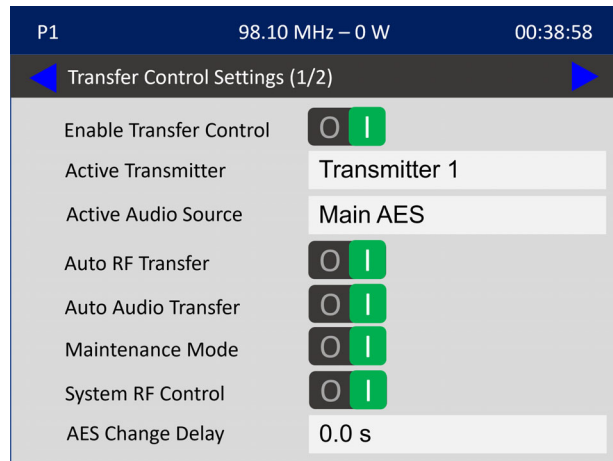

SCREEN 1 OF 2 SHOWN

IMPORTANT! In order for RF output to be enabled, Transfer Control must be enabled and the transmitters set to RF ON when the transmitters are connected to the VS-TC.

The following menus that pertain to the VS-TC are available:

- [Enabling the VS-TC in the Transmitter](#)
- [Selecting the Active Transmitter, on page 3.11](#)
- [Selecting the Active Audio Source, on page 3.13](#)
- [Selecting the RF Transfer Mode, on page 3.15](#)
- [Setting the Audio Transfer Mode, on page 3.17](#)
- [Selecting the Maintenance Mode, on page 3.19](#)
- [Setting System RF Control, on page 3.21](#)
- [Setting the AES Changeover Delay, on page 3.23](#)
- [Setting the AES Return Delay, on page 3.25](#)
- [Setting the AES Changeover Level, on page 3.27](#)
- [Setting the AES Return Level, on page 3.29](#)
- [Setting the RF Changeover Delay, on page 3.31](#)

Enabling the VS-TC in the Transmitter

VS TRANSMITTERS:

From the VS transmitter's front panel UI, you can enable and disable the VS-TC. When enabled, various other UI screens are displayed in the Transfer Control menu (see right-hand side of [Figure 3.3 on page 3.7](#)). To view the Enable screen (see [Figure 3.6](#)) and enable the transfer control function, select Enable in the Transfer Ctrl menu and press the right arrow or the accept (checkmark) button.

Figure 3.6: Enable Screen

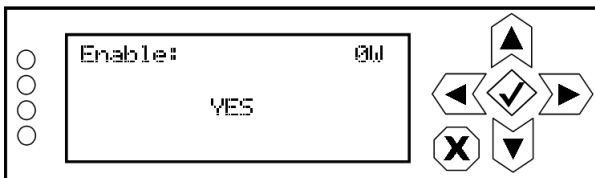

Use the up and down buttons to toggle between YES (to enable) and NO (to disable). Selecting YES enables the other transfer controller sub-menus to display in the Transfer Ctrl menu.

Press the accept (checkmark) button to save the change. Press cancel (X) to discard changes and return to the previous menu.

VX TRANSMITTERS:

From the VX front panel, you can enable and disable the VS-TC. When enabled, various other UI screens are displayed in the Transfer Control menu (see right-hand side of [Figure 3.5 on page 3.8](#)). To enable the transfer control function in the Transfer Control menu, set the Enable Transfer Control toggle switch to I (enabled) (see [Figure 3.7](#)).

Figure 3.7: Enable Screen (VX)

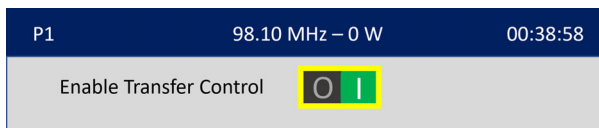

Use the front panel rotary knob to toggle between I (to enable) and O (to disable) and to select. Press Confirm in the confirmation prompt to reboot the transmitter and apply the setting. Press Cancel to abort. Selecting I enables the other transfer controller sub-menus to display in the Transfer Control menu, after the transmitter reboot.

Selecting the Active Transmitter

VS TRANSMITTERS:

From the VS transmitter's front panel UI, you can select the active transmitter (TX 1 or TX 2) for the system (i.e., the transmitter routed to the antenna system). To view the Active Xmtr screen (see [Figure 3.8](#)), select Active Xmtr in the Transfer Ctrl menu and press the right arrow or the accept (checkmark) button.

Figure 3.8: Active Xmtr Screen

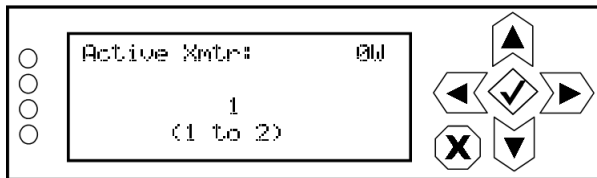

Use the up and down buttons to toggle between 1 (TX 1) and 2 (TX 2). The transmitter that is selected will be routed to the antenna system and the other will be routed to the dummy load, in NORMAL (RF inhibited) mode. Press the accept (checkmark) button to save the change. Press cancel (X) to discard changes and return to the previous menu.

NOTE: Making changes in this screen has the same effect as pressing the MAIN TRANSMITTER SELECT buttons (TX1 or TX2) on the VS-TC's front panel.

VX TRANSMITTERS:

From the VX front panel UI, you can select the active transmitter (Transmitter 1 or Transmitter 2) for the system (i.e., the transmitter routed to the antenna system). The Active Transmitter setting is on the Transfer Control Settings screen (1 of 2) (see [Figure 3.5 on page 3.8](#)).

Use the front panel rotary knob to select the Active Transmitter field, which displays the selection screen shown in [Figure 3.9 on page 3.12](#).

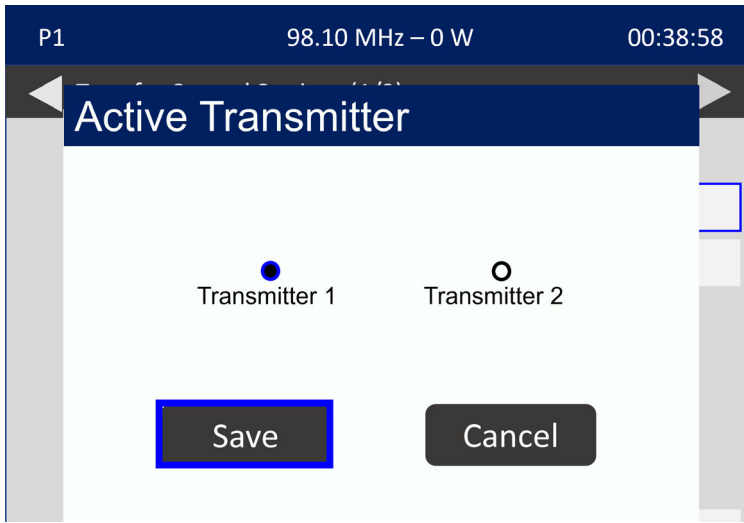
Figure 3.9: Active Transmitter Screen (VX)

Use the front panel rotary knob to select Transmitter 1 or Transmitter 2, and select. The selected option displays a highlighted ordinal, as shown for Transmitter 1 in [Figure 3.9](#). Highlight and select Save to apply the setting. Select Cancel to return to the previous screen. The saved selection will display in the Active Transmitter field in [Figure 3.5 on page 3.8](#).

NOTE: Making changes in this screen has the same effect as pressing the MAIN TRANSMITTER SELECT buttons (TX1 or TX2) on the VS-TC's front panel.

Selecting the Active Audio Source

VS TRANSMITTERS:

From the VS transmitter's front panel UI, you can select the active AES audio source (MAIN or BACKUP) that will be applied to both transmitters. To view the Active Audio screen (see [Figure 3.10](#)), select Active Audio in the Transfer Ctrl menu and press the right arrow or the accept (checkmark) button.

Figure 3.10: Active Audio Screen

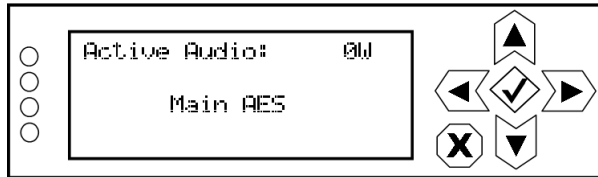

Use the up and down buttons to toggle between Main AES and Backup AES. The audio source that is selected will be applied to both VS transmitters. Press the accept (checkmark) button to save the change. Press cancel (X) to discard changes and return to the previous menu.

NOTE: Making changes in this screen has the same effect as pressing the AUDIO SOURCE buttons (MAIN or BACKUP) on the VS-TC's front panel.

VX TRANSMITTERS:

From the VX front panel UI, you can select the active audio source (Main AES or Backup AES) that will be applied to both transmitters. The Active Audio Source setting is on the Transfer Control Settings screen (1 of 2) (see [Figure 3.5 on page 3.8](#)).

Use the front panel rotary knob to select the Active Audio Source field, which displays the selection screen shown in [Figure 3.11 on page 3.14](#).

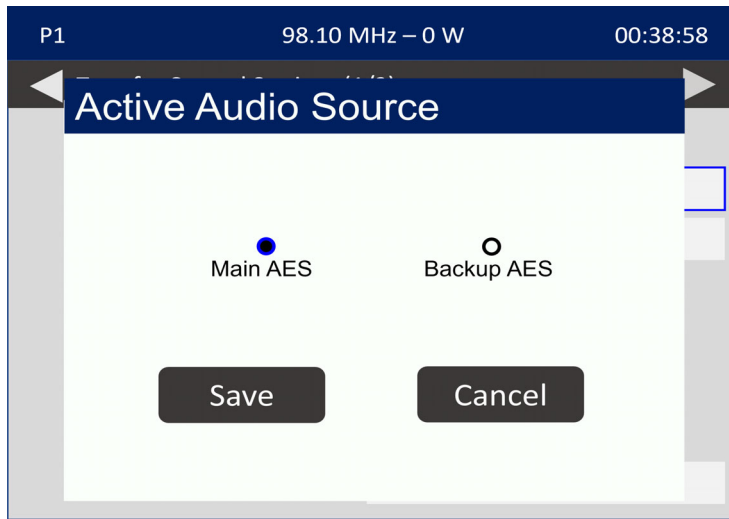
Figure 3.11: Active Audio Source Screen (VX)

Use the front panel rotary knob to select Main AES or Backup AES, and select. The selected option displays a highlighted ordinal, as shown for Main AES in [Figure 3.11](#). Highlight and select Save to apply the setting. Select Cancel to return to the previous screen. The saved selection will display in the Active Audio Source field in [Figure 3.5 on page 3.8](#).

NOTE: Making changes in this screen has the same effect as pressing the AUDIO SOURCE buttons (MAIN or BACKUP) on the VS-TC's front panel.

Selecting the RF Transfer Mode

VS TRANSMITTERS:

From the VS transmitter's front panel UI, you can set the RF transfer mode (automatic or manual changeover) for the transmitter system.

In automatic mode, the main transmitter is on-air unless its RF output falls below a preset threshold for longer than a preset delay (0 to 300 s). This causes an RF transfer and the standby transmitter becomes the on-air transmitter. The low RF output threshold is set using the VS transmitters in their UI's User Settings -> Fwd Low screen. The RF transfer delay is set using the VS transmitters in their UI's System Settings -> Transfer Ctrl -> RF Chg Dly screen (see [Setting the RF Changeover Delay, on page 3.31](#)) or using a terminal program via the CONSOLE port (see [RF Changeover Delay, on page 3.40](#)).

In Manual mode, the active transmitter is on-air and there is no automatic changeover. To view the RF Mode screen (see [Figure 3.12](#)), select RF Mode in the Transfer Ctrl menu and press the right arrow or the accept (checkmark) button.

Figure 3.12: RF Mode Screen

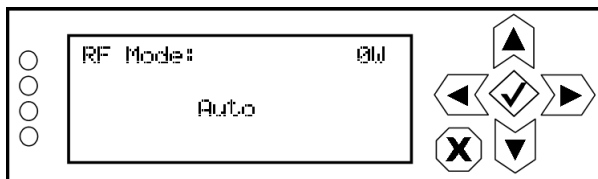

Use the up and down buttons to toggle between Auto (enables changeover) and Manual (disables changeover). Press the accept (checkmark) button to save the change. Press cancel (X) to discard changes and return to the previous menu.

NOTE: Making changes in this screen has the same effect as pressing the RF TRANSFER buttons (AUTO or MANUAL) on the VS-TC's front panel.

VX TRANSMITTERS:

From the VX front panel, you can enable and disable automatic RF transfer for the transmitter system.

In automatic mode, the main transmitter is on-air unless its RF output falls below a preset threshold for longer than a preset delay (0.1 to 300 s). This causes an RF transfer and the standby transmitter becomes the on-air transmitter. The low RF output threshold is set using the transmitters in their UI's Settings -> Transmitter -> Forward Low screen. The RF transfer delay is set using the transmitters in their UI's Settings -> System -> Transfer Control -> RF Change Delay screen (see [Setting the RF Changeover Delay, on page 3.31](#)) or using a terminal program via the CONSOLE port (see [RF Changeover Delay;, on page 3.40](#)).

In manual mode (i.e., automatic transfer disabled), the active transmitter is on-air and there is no automatic changeover.

To enable automatic RF transfer in the Transfer Control Settings menu (see [Figure 3.13](#)), set the Auto RF Transfer toggle switch to I (enabled).

Figure 3.13: Auto RF Transfer Selection (VX)

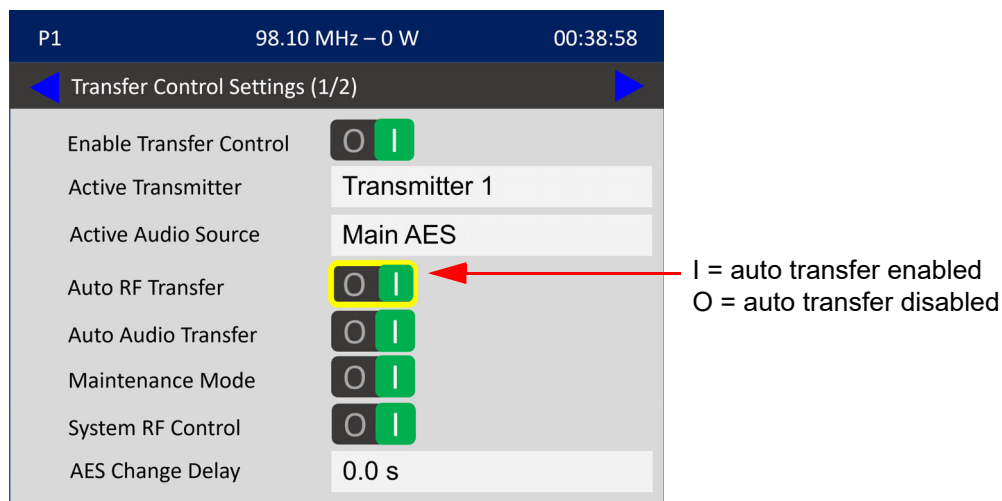

Use the front panel rotary knob to toggle between I (to enable) and O (to disable), then press to select and apply the setting.

NOTE: Making changes in this screen has the same effect as pressing the RF TRANSFER buttons (AUTO or MANUAL) on the VS-TC's front panel.

Setting the Audio Transfer Mode

VS TRANSMITTERS:

From the VS transmitter's front panel UI, you can set the audio transfer mode (automatic or manual changeover) for the transmitter system. In automatic mode, the main AES audio is active unless its amplitude falls below a preset threshold for longer than a preset delay period (see [Setting the AES Changeover Delay, on page 3.23](#)). This causes an audio transfer and the backup audio becomes active. The system will return to the main AES source if the main AES level is above the preset return level for longer than the preset return delay period (see [Setting the AES Return Level, on page 3.29](#) and [Setting the AES Return Delay, on page 3.25](#)). In Manual mode, the selected audio is active and there is no automatic changeover. To view the Audio Mode screen (see [Figure 3.14](#)), select Audio Mode in the Transfer Ctrl menu and press the right arrow or the accept (checkmark) button.

Figure 3.14: Audio Mode Screen

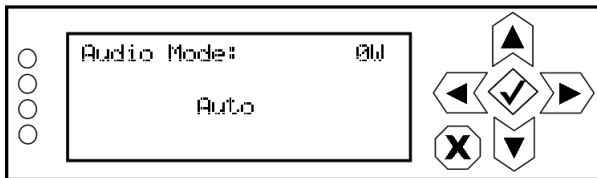

Use the up and down buttons to toggle between Auto (enables changeover) and Manual (disables changeover). Press the accept (checkmark) button to save the change. Press cancel (X) to discard changes and return to the previous menu.

NOTE: Making changes in this screen has the same effect as pressing the AUDIO TRANSFER buttons (AUTO or MANUAL) on the VS-TC's front panel.

VX TRANSMITTERS:

From the VX front panel UI, you can enable and disable automatic RF transfer for the transmitter system.

In automatic mode, the main AES audio is active unless its amplitude falls below a preset threshold for longer than a preset delay period (see [Setting the AES Changeover Delay, on page 3.23](#)). This causes an audio transfer and the backup audio becomes active. The system will return to the main AES source if the main AES level is above the preset return level for longer than the preset return delay period (see [Setting the AES Return Level, on page 3.29](#) and [Setting the AES Return Delay, on page 3.25](#)).

In manual mode (i.e., automatic transfer disabled), the selected audio is active and there is no automatic changeover. To enable automatic audio transfer in the Transfer Control Settings menu (see [Figure 3.15](#)), set the Auto RF Transfer toggle switch to I (enabled).

Figure 3.15: Auto Audio Transfer Selection (VX)

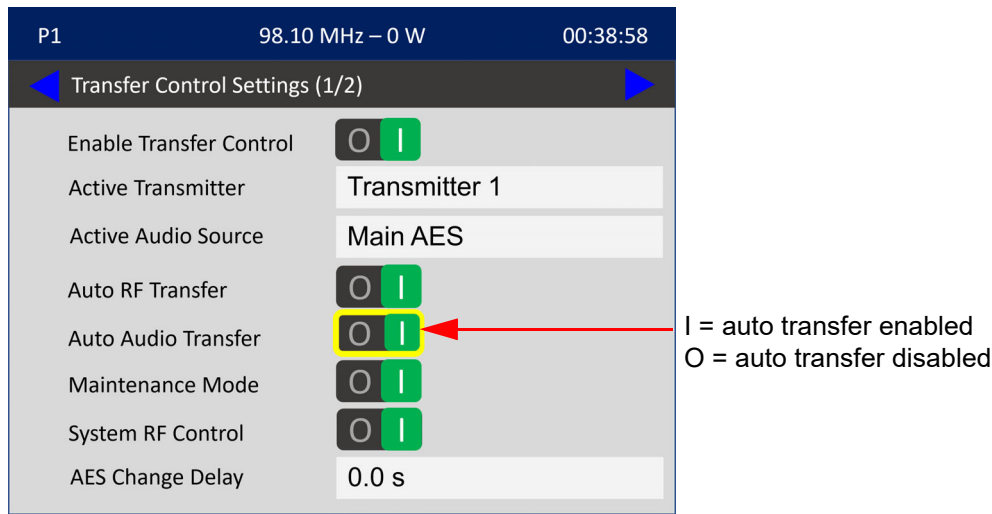

Use the front panel rotary knob to toggle between I (to enable) and O (to disable), then press to select and apply the setting.

NOTE: Making changes in this screen has the same effect as pressing the AUDIO TRANSFER buttons (AUTO or MANUAL) on the VS-TC's front panel.

Selecting the Maintenance Mode

VS TRANSMITTERS:

From the VS transmitter's front panel UI, you can set the maintenance mode (normal or maintenance) for the transmitter system. In normal mode, the standby transmitter is routed to the dummy load, but its RF is inhibited. In this mode, automatic changeover is possible. In maintenance mode, the standby transmitter's RF output is enabled into the dummy load to allow testing and maintenance. In this mode, automatic RF changeover is disabled. To view the Maintenance Mode screen (see [Figure 3.16](#)), select Maint Mode in the Transfer Ctrl menu and press the right arrow or the accept (checkmark) button.

Figure 3.16: Maintenance Mode Screen

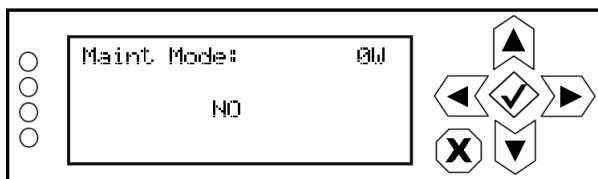

Use the up and down buttons to toggle between NO (normal mode) and YES (maintenance mode). Press the accept (checkmark) button to save the change. Press cancel (X) to discard changes and return to the previous menu.

NOTE: Making changes in this screen has the same effect as pressing the MODE buttons (NORMAL or MAINTENANCE) on the VS-TC's front panel.

VX TRANSMITTERS:

From the VX front panel UI, you can enable and disable the maintenance mode for the transmitter system.

In normal mode (i.e., maintenance mode disabled), the standby transmitter is routed to the dummy load, but its RF is inhibited. In this mode, automatic changeover is possible.

In maintenance mode, the standby transmitter's RF output is enabled into the dummy load to allow testing and maintenance. In this mode, automatic RF changeover is disabled.

To enable maintenance mode in the Transfer Control Settings menu (see [Figure 3.17](#)), set the Maintenance Mode toggle switch to I (enabled).

Figure 3.17: Maintenance Mode Selection (VX)

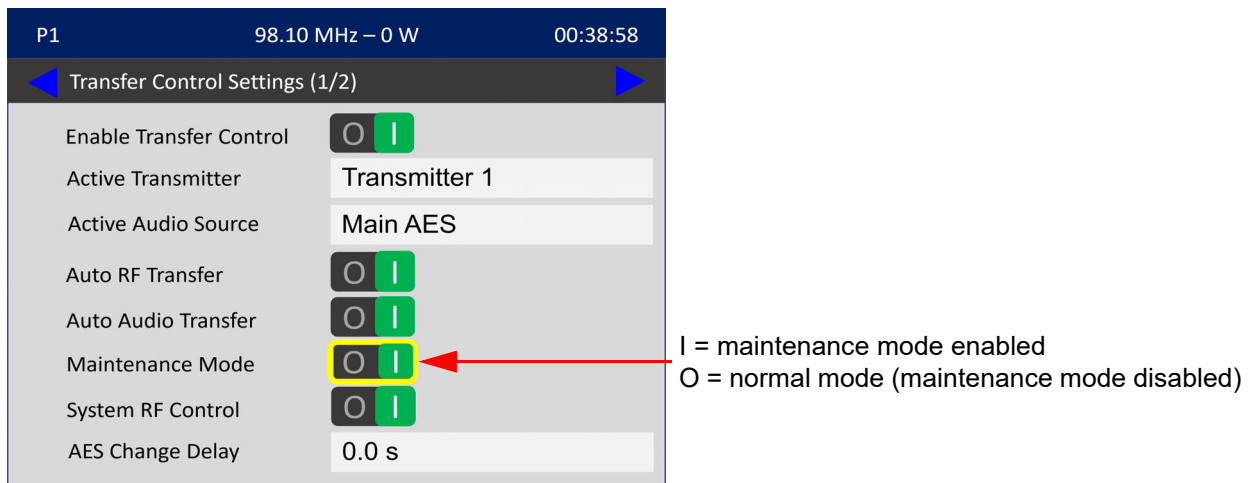

Use the front panel rotary knob to toggle between I (maintenance mode) and O (normal mode), then press to select and apply the setting.

NOTE: Making changes in this screen has the same effect as pressing the MODE buttons (NORMAL or MAINTENANCE) on the VS-TC's front panel.

Setting System RF Control

VS TRANSMITTERS:

From the VS transmitter's front panel UI, you can control the system's RF status (RF on or RF off). If RF On is selected, the on-air transmitter's RF power stage is enabled (the standby transmitter depends on the maintenance mode). If RF Off is selected, the RF power stage for both transmitters will be disabled. To view the System RF Control screen (see [Figure 3.18](#)), select Sys RF Ctrl in the Transfer Ctrl menu and press the right arrow or the accept (checkmark) button.

Figure 3.18: System RF Control Screen

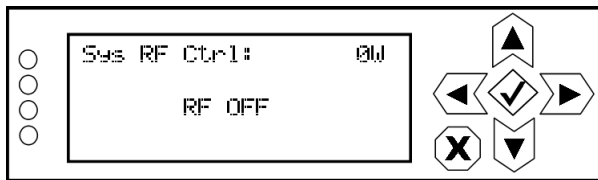

Use the up and down buttons to toggle between RF ON and RF OFF. Press the accept (checkmark) button to save the change. Press cancel (X) to discard changes and return to the previous menu.

NOTE: The VS-TC sends 'RF mute' commands to the VS transmitters to enable or disable their RF outputs. Both VS transmitters must be configured for RF On to operate in the main-standby system.

NOTE: Making changes in this screen has the same effect as pressing the RF ON or RF OFF button on the VS-TC's front panel.

VX TRANSMITTERS:

From the VX front panel UI, you can control the system's RF status (RF on or RF off).

If System RF Control is enabled (RF on), the on-air transmitter's RF power stage is enabled (the standby transmitter depends on the maintenance mode).

If System RF Control is disabled (RF off), the RF power stage for both transmitters will be disabled.

To enable System RF Control in the Transfer Control Settings menu (see [Figure 3.19](#)), set the System RF Control toggle switch to I (enabled).

Figure 3.19: System RF Control Selection (VX)

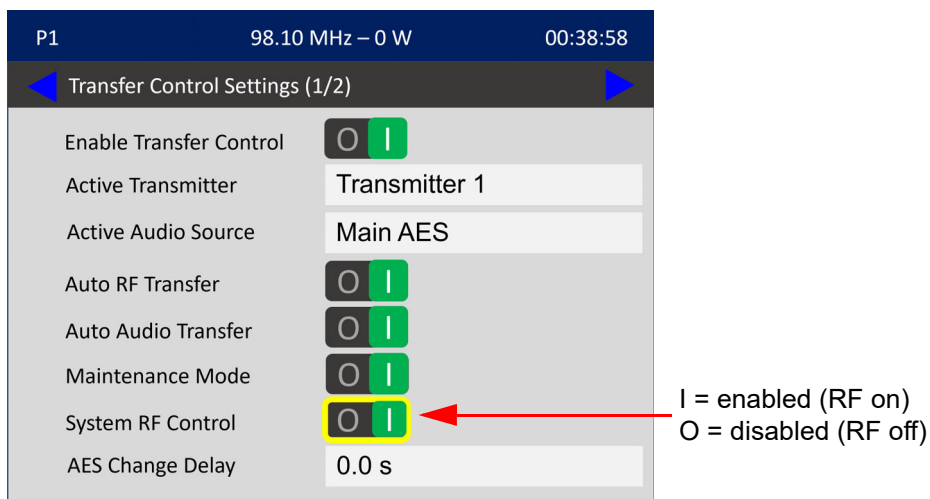

Use the front panel rotary knob to toggle between I (enabled, RF on) and O (disabled, RF off), then press to select and apply the setting.

NOTE: The VS-TC sends 'RF mute' commands to the transmitters to enable or disable their RF outputs. Both transmitters must be configured for RF On to operate in the main-standby system.

NOTE: Making changes in this screen has the same effect as pressing the RF ON or RF OFF button on the VS-TC's front panel.

Setting the AES Changeover Delay

VS TRANSMITTERS:

From the VS transmitter's front panel UI, you can set the desired amount of time to wait before initiating an AES changeover after the main AES level falls below its preset threshold. This value is only relevant when the audio transfer mode is set to automatic. To view the AES Changeover Delay screen (see [Figure 3.20](#)), select AES Chg Dly in the Transfer Ctrl menu and press the right arrow or the accept (checkmark) button.

Figure 3.20: AES Changeover Delay Screen

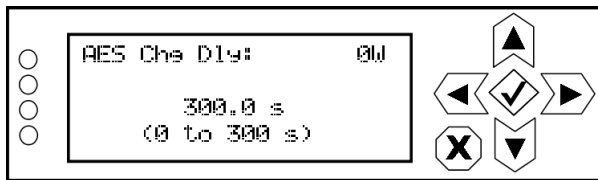

Use the up and down buttons to select a value between 0.1 and 300 s (in 0.1 s increments). The factory default delay is 300 s. Press the accept (checkmark) button to save the change. Press cancel (X) to discard changes and return to the previous menu.

NOTE: *Setting the value to 0 will automatically revert the value to its previous setting.*

VX TRANSMITTERS:

From the VX front panel UI, you can set the desired amount of time to wait before initiating an AES changeover after the main AES level falls below its preset threshold. This value is only relevant when the audio transfer mode is set to automatic. The AES Change Delay setting is on the Transfer Control Settings screen (1 of 2) (see [Figure 3.5 on page 3.8](#)).

Use the front panel rotary knob to select the AES Change Delay field, which displays the setting screen shown in [Figure 3.21](#).

Figure 3.21: AES Change Delay Setting Screen (VX)

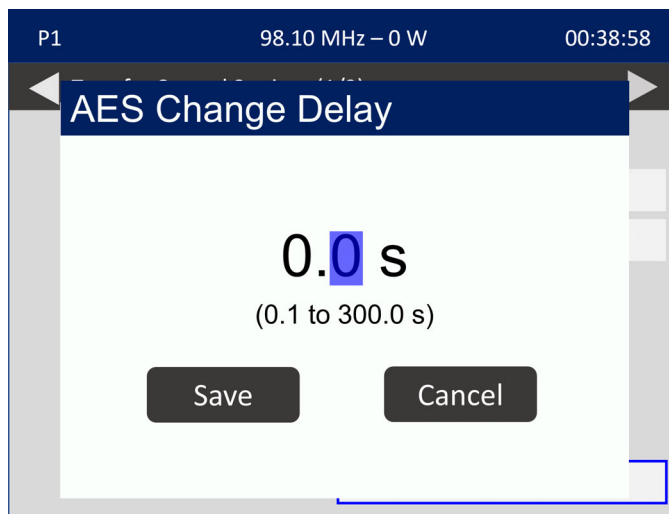

Use the Front Panel rotary knob to edit and select a value between 0.1 and 300.0 s (in 0.1 s increments). The factory default is 300 s. Press the Save button to apply the change. Press the Cancel button to discard the change and return to the previous menu. The saved selection will display in the AES Change Delay field in [Figure 3.5 on page 3.8](#).

NOTE: *Setting the value to 0 will automatically revert the value to its previous setting.*

Setting the AES Return Delay

VS TRANSMITTERS:

From the VS transmitter's front panel UI, you can set the desired amount of time to wait before the main AES audio will be restored as the active source, upon its level exceeding the AES Return Threshold. This value is only relevant when the audio transfer mode is set to automatic. To view the AES Return Delay screen (see [Figure 3.22](#)), select AES Ret Dly in the Transfer Ctrl menu and press the right arrow or the accept (checkmark) button.

Figure 3.22: AES Return Delay Screen

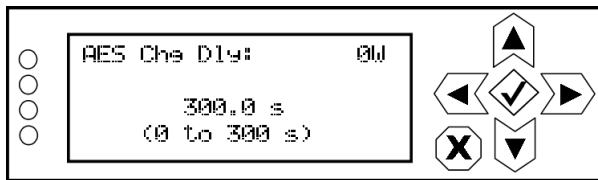

Use the up and down buttons to select a value between 0.1 and 300 s (in 0.1 s increments). The factory default delay is 300 s. Press the accept (checkmark) button to save the change. Press cancel (X) to discard changes and return to the previous menu.

NOTE: *Setting the value to 0 will automatically revert the value to its previous setting.*

VX TRANSMITTERS:

From the VX front panel UI, you can set the desired amount of time to wait before the main AES audio will be restored as the active source, upon its level exceeding the AES Recovery Threshold. This value is only relevant when the audio transfer mode is set to automatic.

To view the AES Recovery Delay field, go to Transfer Control Settings screen 2 of 2 (see [Figure 3.23](#)).

Figure 3.23: Transfer Control Settings (screen 2 of 2) (VX)

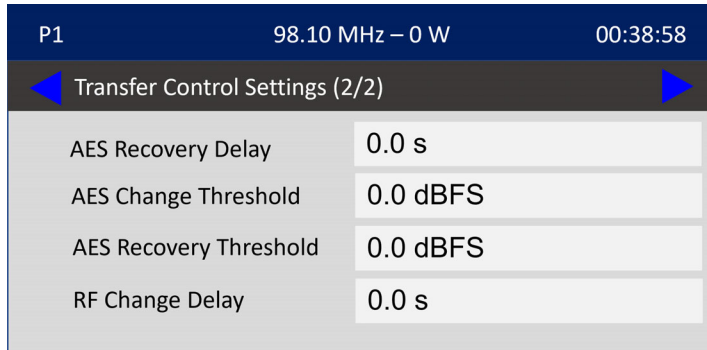

Use the front panel rotary knob to select the AES Change Delay field, which displays the setting screen shown in [Figure 3.24](#).

Figure 3.24: AES Recovery Delay Setting Screen (VX)

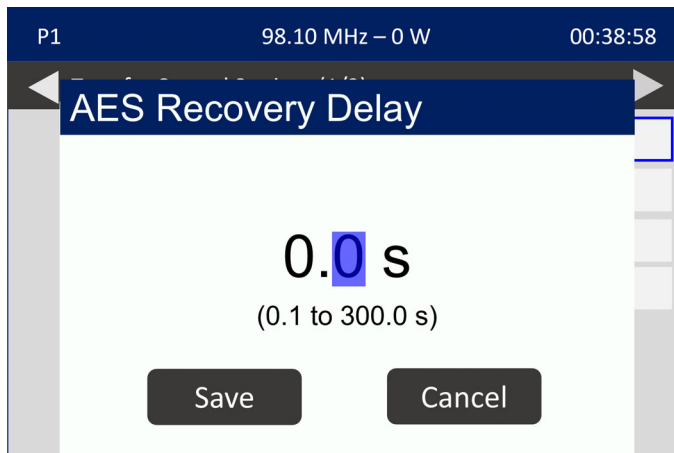

Use the Front Panel rotary knob to edit and select a value between 0.1 and 300.0 s (in 0.1 s increments). The factory default is 300 s. Press the Save button to apply the change. Press the Cancel button to discard the change and return to the previous menu. The saved selection will display in the AES Recovery Delay field in [Figure 3.23](#).

NOTE: *Setting the value to 0 will automatically revert the value to its previous setting.*

Setting the AES Changeover Level

VS TRANSMITTERS:

From the VS transmitter's front panel UI, you can set the threshold below which an AES transfer will initiate (after the AES changeover delay period). This value is only relevant when the audio transfer mode is set to automatic. To view the AES Changeover Level screen (see [Figure 3.20](#)), select AES Chg Lvl in the Transfer Ctrl menu and press the right arrow or the accept (checkmark) button.

Figure 3.25: AES Changeover Level Screen

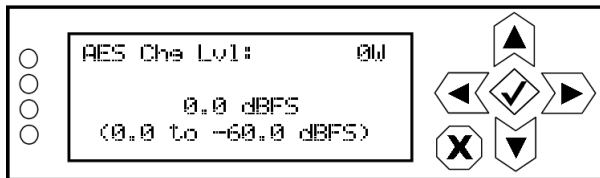

Use the up and down buttons to select a value between -0.1 and -60.0 dBFS (in 0.1 dBFS increments). The factory default level is -60.0 dBFS. Press the accept (checkmark) button to save the change. Press cancel (X) to discard changes and return to the previous menu.

NOTE: *Setting the value to 0.0 will automatically revert the value to its previous setting.*

VX TRANSMITTERS:

From the VX front panel UI, you can set the threshold below which an AES transfer will initiate (after the AES changeover delay period). This value is only relevant when the audio transfer mode is set to automatic. The AES Change Threshold setting is on the Transfer Control Settings screen (1 of 2) (see [Figure 3.23 on page 3.26](#)).

Use the front panel rotary knob to select the AES Change Threshold field, which displays the setting screen shown in [Figure 3.26](#).

Figure 3.26: AES Change Threshold Setting Screen (VX)

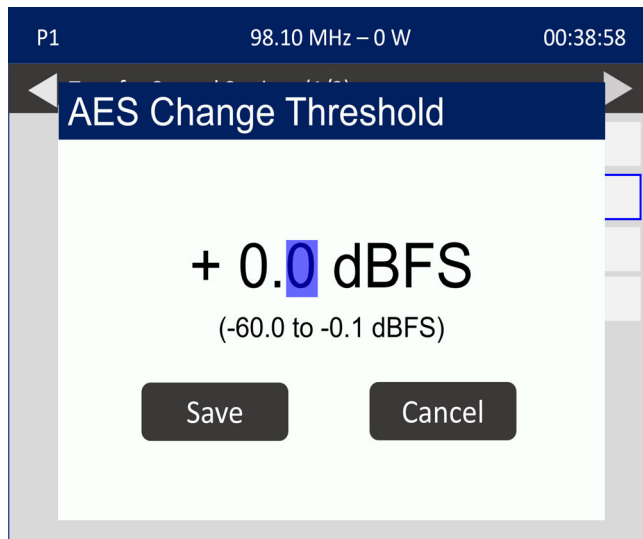

Use the Front Panel rotary knob to edit and select a value between -60.0 and -0.1 dBFS (in 0.1 dBFS increments). The factory default level is -60.0 dBFS. Press the Save button to apply the change. Press the Cancel button to discard the change and return to the previous menu. The saved selection will display in the AES Recovery Delay field in [Figure 3.23](#).

NOTE: *Setting the value to 0.0 will automatically revert the value to its previous setting.*

Setting the AES Return Level

VS TRANSMITTERS:

From the VS transmitter's front panel UI, you can set the threshold above which the main AES audio will be restored as the active source (after the AES return delay period). This value is only relevant when the audio transfer mode is set to automatic. To view the AES Return Level screen (see [Figure 3.27](#)), select AES Ret Lvl in the Transfer Ctrl menu and press the right arrow or the accept (checkmark) button.

Figure 3.27: AES Return Level Screen

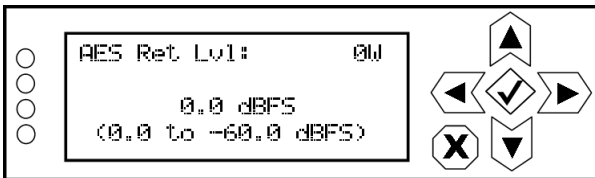

Use the up and down buttons to select a value between -0.1 and -60.0 dBFS (in 0.1 dBFS increments) and must also be of equal or greater amplitude as the AES Changeover Level. The factory default level is -60.0 dBFS. Press the accept (checkmark) button to save the change. Press cancel (X) to discard changes and return to the previous menu.

NOTE: *Setting the value to 0.0 will automatically revert the value to its previous setting.*

VX TRANSMITTERS:

From the VX front panel UI, you can set the threshold above which the main AES audio will be restored as the active source (after the AES recovery delay period). This value is only relevant when the audio transfer mode is set to automatic. The AES Recovery Threshold setting is on the Transfer Control Settings screen (1 of 2) (see [Figure 3.23 on page 3.26](#)).

Use the front panel rotary knob to select the AES Recovery Threshold field, which displays the setting screen shown in [Figure 3.28](#).

Figure 3.28: AES Recovery Threshold Setting Screen (VX)

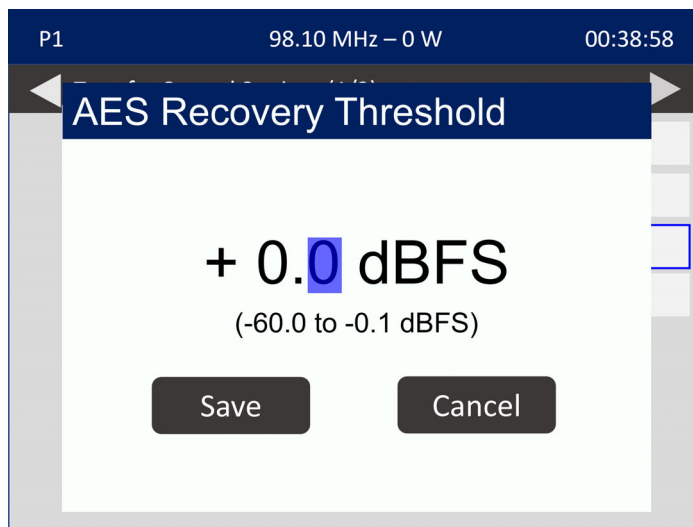

Use the Front Panel rotary knob to edit and select a value between -60.0 and -0.1 dBFS (in 0.1 dBFS increments). The factory default level is -60.0 dBFS. Press the Save button to apply the change. Press the Cancel button to discard the change and return to the previous menu. The saved selection will display in the AES Recovery Threshold field in [Figure 3.23 on page 3.26](#).

NOTE: *Setting the value to 0.0 will automatically revert the value to its previous setting.*

Setting the RF Changeover Delay

VS TRANSMITTERS:

From the VS transmitter's front panel UI, you can set the desired amount of time to wait before initiating an RF changeover after the main transmitter's RF output falls below its preset low threshold. This value is only relevant when the RF transfer mode is set to automatic. To view the RF Changeover Delay screen (see [Figure 3.29](#)), select RF Chg Dly in the Transfer Ctrl menu and press the right arrow or the accept (checkmark) button.

Figure 3.29: RF Changeover Delay Screen

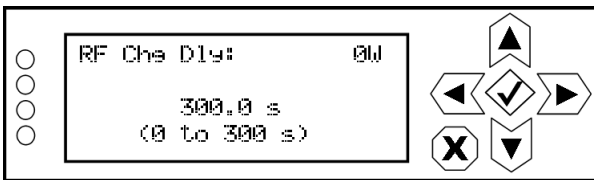

Use the up and down buttons to select a value between 0.1 and 300 s (in 0.1 s increments). The factory default delay is 300 s. Press the accept (checkmark) button to save the change. Press cancel (X) to discard changes and return to the previous menu.

NOTE: *Setting the value to 0 will automatically revert the value to its previous setting.*

VX TRANSMITTERS:

From the VX front panel UI, you can set the desired amount of time to wait before initiating an RF changeover after the main transmitter's RF output falls below its preset low threshold. This value is only relevant when the RF transfer mode is set to automatic. The RF Change Delay setting is on the Transfer Control Settings screen (1 of 2) (see [Figure 3.23 on page 3.26](#)).

Use the front panel rotary knob to select the RF Change Delay field, which displays the setting screen shown in [Figure 3.30](#).

Figure 3.30: RF Change Delay Setting Screen (VX)

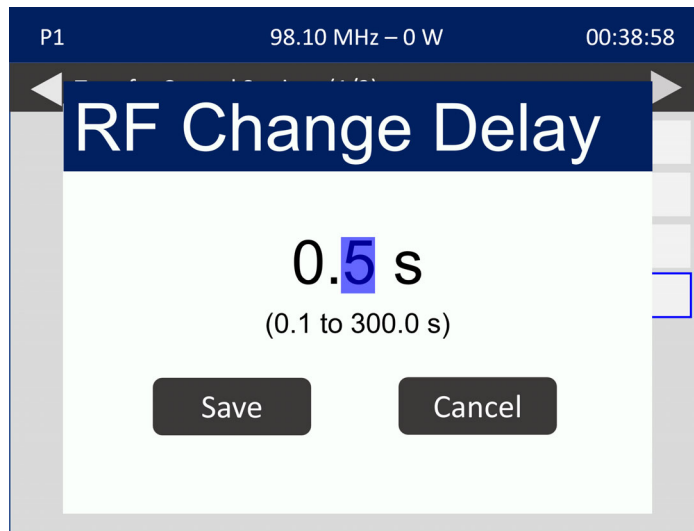

Use the Front Panel rotary knob to edit and select a value between 0.1 and 300 s (in 0.1 s increments). The factory default delay is 300 s. Press the Save button to apply the change. Press the Cancel button to discard the change and return to the previous menu. The saved selection will display in the RF Change Delay field in [Figure 3.23 on page 3.26](#).

NOTE: *Setting the value to 0.0 will automatically revert the value to its previous setting.*

Remote Operation

You can control and monitor the main-standby transmitter system without accessing the local controls described in [Controls and Indicators, on page 3.3](#).

To accept any remote commands, the system must first be placed in the remoted enabled mode (local + remote control) by setting the front panel CONTROL switch to REMOTE mode (see [Controls and Indicators, on page 3.3](#)).

There are two methods to remotely interface with the VS-TC:

- Using a terminal program (e.g., PuTTY) on a laptop or PC that is connected to the CONSOLE port on the VS-TC's front panel. See [Using the CONSOLE Port](#).
- Using discrete input/output wiring connected between a remote control site and the REMOTE I/O connector on the rear of the VS-TC. See Section 2 - Preparation for Use and Installation for more details on the required control/monitor connections.

Using the CONSOLE Port

1. Connect the USB cable (Nautel Part # UB98) between the CONSOLE USB port on the front panel of the VS-TC and an available USB port on a PC or laptop. If necessary, follow normal Windows Update procedures to install a driver for the USB device.
2. Ensure a terminal program (e.g., PuTTY) is installed on the PC or laptop. If necessary, download putty.exe from <http://www.chiark.greenend.org.uk/~sgtatham/putty/download.html>. Choose the first download in the list and save it to your desktop.
3. Determine the COM port number that has been assigned to the USB connection.
 - ❖ Open the Control Panel Device Manager. The exact procedure will vary depending on the version of Windows you are using.
 - ❖ Expand the Ports (COM & LPT) section.
 - ❖ Note the COM port identified as "USB Serial Port". In the example shown in [Figure 3.31 on page 3.34](#), it is COM10.

Figure 3.31: Device manager - COM Port Identification

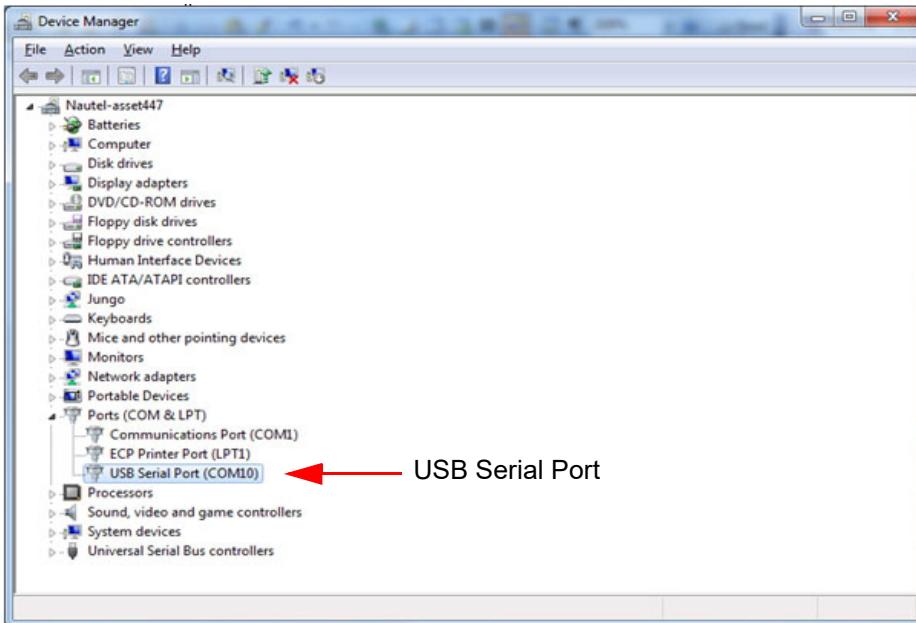

4. Open the PuTTY serial terminal program. Set the Connection Type to Serial.
5. See Figure 3.32. Enter the COM port number identified in Step 3 in the Serial line field (e.g., COM10). Enter 115200 in the Speed field. Click Open.

Figure 3.32: PuTTY Configuration Screen

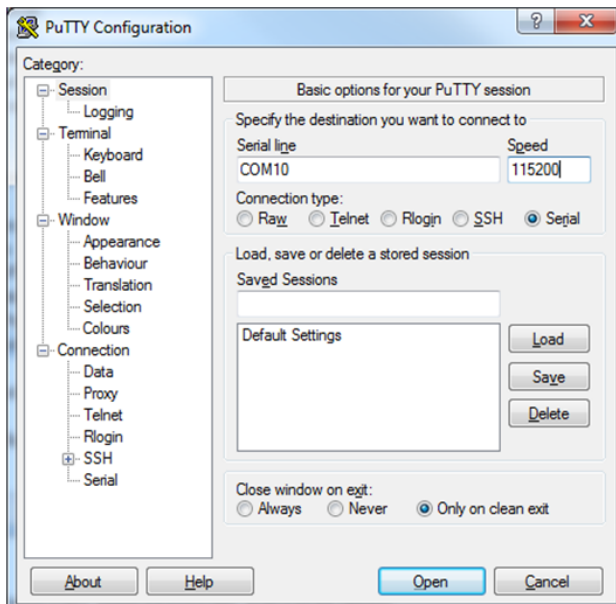

6. Press Enter to display the prompt to enter the serial menu. Type serialmenu to enter the menu.

Type "serialmenu" to enter the menu
Type "erialmenu" to enter the menu
Type "rialmenu" to enter the menu
Type "ialmenu" to enter the menu
Type "almenu" to enter the menu
Type "lmenu" to enter the menu
Type "menu" to enter the menu
Type "enu" to enter the menu
Type "nu" to enter the menu
Type "u" to enter the menu

NOTE: After typing "u", the menu in [Figure 3.33](#) will appear.

Figure 3.33: Terminal Program Main Menu

```
VS Transfer Controller version 1.1.0.1 ← SOFTWARE VERSION
                                     (may not be exactly as shown)

Main Menu
=====
F) Show Faults
M) Show Meters
C) Configure Thresholds
T) Set Active Transmitter (TX1)
A) Set Active Audio Source (MAIN)
X) Set RF Transfer Mode (MANUAL) ← Current state shown
Y) Set Audio Transfer Mode (MANUAL)   in parentheses
N) Set Maintenance Mode (NORMAL)
R) Turn RF On/Off (RF ON)
D) Restore Factory Defaults
E) Reset CPU into NCodeUploader mode
Q) Quit

Enter your choice:
```

Enter the desired alpha character (e.g., F or f to Show Faults) to display the applicable sub-menu. The following sub-menus are available:

- ❖ F) Show Faults sub-menu - see page 3.37
- ❖ M) Show Meters sub-menu - see page 3.37
- ❖ C) Configure Thresholds sub-menu - see page 3.38
 - AES Changeover Delay: - see page 3.38
 - AES Changeover Threshold: - see page 3.39
 - AES Return Delay: - see page 3.39
 - AES Return Threshold: - see page 3.40
 - RF Changeover Delay: - see page 3.40
- ❖ T) Set Active Transmitter sub-menu - see page 3.41
- ❖ A) Set Active Audio Source sub-menu - see page 3.42
- ❖ X) Set RF Transfer Mode sub-menu - see page 3.43
- ❖ Y) Set Audio Transfer Mode sub-menu - see page 3.44
- ❖ N) Set Maintenance Mode sub-menu - see page 3.45
- ❖ R) Turn RF On/Off sub-menu - see page 3.46
- ❖ D) Restore Factory Defaults sub-menu - see page 3.47
- ❖ E) Reset CPU into NCodeUploader Mode sub-menu - see page 3.48

Enter Q to quit the terminal program.

SHOW FAULTS SUB-MENU

When you enter F (or f) as your choice in the Main Menu (see [Figure 3.33 on page 3.35](#)), a list of active alarms is displayed:

```
Active alarms:  
Main AES Unlocked  
Backup AES Unlocked
```



Only active faults are listed

See [SECTION 4: Troubleshooting](#) for a complete list of faults that can appear in the Active alarms list, as well as fault descriptions and suggested troubleshooting actions.

SHOW METERS SUB-MENU

When you enter M (or m) as your choice in the Main Menu (see [Figure 3.33 on page 3.35](#)), the following meters, and their current values, are displayed:

```
24V Supply A: 24.1 V  
24V Supply B: 24.4 V  
1.8V Supply: 1.82 V  
3.3V Supply: 3.32 V  
15V Supply: 15.1 V  
Main AES Peak: -90.0 dBFS  
Backup AES Peak: -90.0 dBFS
```

CONFIGURE THRESHOLDS SUB-MENU

When you enter C (or c) as your choice in the Main Menu (see [Figure 3.33 on page 3.35](#)), the following menu is displayed:

```

Thresholds Menu
=====
A) AES Changeover Delay      (300.0 s)
T) AES Changeover Threshold  (-60.0 dBFS)
R) AES Return Delay          (300.0 s)
V) AES Return Threshold      (-60.0 dBFS)
F) RF Changeover Delay       (300.0 s)
Q) Return to previous menu

```

Enter your choice:

From the Thresholds Menu, there are four additional sub-menus that allow specific parameter configuration. Enter the desired alpha character (e.g., A or a for AES Changeover Delay) to display the applicable sub-menu. Enter Q to return to the Main Menu.

AES CHANGEOVER DELAY: When you enter A (or a) as your choice in the Thresholds Menu, you can set the desired amount of time to wait before initiating an AES changeover after the main AES level falls below its preset threshold. The value must be between 0.1 and 300 s (see below).

NOTE: *Setting the value to 0 will automatically revert the value to its previous setting.*

```

Enter your choice: a
Enter AES changeover delay (0.0 to 300.0 s) > 0.1 ← e.g., enter 0.1

```

```

Thresholds Menu
=====
A) AES Changeover Delay      (0.1 s) ← New value displayed upon
T) AES Changeover Threshold  (-60.0 dBFS)      return to Thresholds Menu
R) AES Return Delay          (300.0 s)
V) AES Return Threshold      (-60.0 dBFS)
F) RF Changeover Delay       (300.0 s)
Q) Return to previous menu

```

Enter your choice:

AES CHANGEOVER THRESHOLD: When you enter T (or t) as your choice in the Thresholds Menu, you can set the threshold below which an AES transfer will initiate (after the AES changeover delay period). The value must be between -0.1 and -60 dBFS (see below).

NOTE: *Setting the value to 0 will automatically revert the value to its previous setting.*

Enter your choice: t
 Enter AES changeover threshold (0.0 to -60.0 dBFS) > -0.1  e.g., enter -0.1

Thresholds Menu

=====

- A) AES Changeover Delay (300.0 s)
- T) AES Changeover Threshold (-0.1 dBFS)  **New value displayed upon return to Thresholds Menu**
- R) AES Return Delay (300.0 s)
- V) AES Return Threshold (-60.0 dBFS)
- F) RF Changeover Delay (300.0 s)
- Q) Return to previous menu

Enter your choice:

AES RETURN DELAY: When you enter R (or r) as your choice in the Thresholds Menu, you can set the desired amount of time to wait before the main AES audio will be restored as the active source, upon its level exceeding the AES Return Threshold. The value must be between 0.1 and 300 s (see below).

NOTE: *Setting the value to 0 will automatically revert the value to its previous setting.*

Enter your choice: r
 Enter AES return delay (0.0 to 300.0 s) > 0.1  e.g., enter 0.1

Thresholds Menu

=====

- A) AES Changeover Delay (300.0 s)
- T) AES Changeover Threshold (-60.0 dBFS)
- R) AES Return Delay (0.1 s)  **New value displayed upon return to Thresholds Menu**
- V) AES Return Threshold (-60.0 dBFS)
- F) RF Changeover Delay (300.0 s)
- Q) Return to previous menu

Enter your choice:

AES RETURN THRESHOLD: When you enter V (or v) as your choice in the Thresholds Menu, you can set the threshold above which the main AES audio will be restored as the active source (after the AES return delay period). The value must be between -0.1 and -60 dBFS, and must also be of equal or greater amplitude as the AES Changeover Threshold value (see below).

NOTE: *Setting the value to 0 will automatically revert the value to its previous setting.*

Enter your choice: t
 Enter AES changeover threshold (0.0 to -60.0 dBFS) > -0.1  e.g., enter -0.1

Thresholds Menu
 =====

- A) AES Changeover Delay (300.0 s)
- T) AES Changeover Threshold (-60.0 dBFS)
- R) AES Return Delay (300.0 s)
- V) AES Return Threshold (-0.1 dBFS)  New value displayed upon return to Thresholds Menu
- F) RF Changeover Delay (300.0 s)
- Q) Return to previous menu

Enter your choice:

RF CHANGEOVER DELAY: When you enter F (or f) as your choice in the Thresholds Menu, you can set the desired amount of time to wait before initiating an RF changeover after the main transmitter’s RF level falls below its preset threshold. The value must be between 0.1 and 300 s (see below).

NOTE: *Setting the value to 0 will automatically revert the value to its previous setting.*

Enter your choice: f
 Enter RF changeover delay (0.0 to 300.0 s) > 0.1  e.g., enter 0.1

Thresholds Menu
 =====

- A) AES Changeover Delay (300.0 s)
- T) AES Changeover Threshold (-60.0 dBFS)
- R) AES Return Delay (300.0 s)
- V) AES Return Threshold (-60.0 dBFS)
- F) RF Changeover Delay (0.1 s)  New value displayed upon return to Thresholds Menu
- Q) Return to previous menu

Enter your choice:

SET ACTIVE TRANSMITTER SUB-MENU

When you enter T (or t) as your choice in the Main Menu (see [Figure 3.33 on page 3.35](#)), you can set the active transmitter for operation into the antenna system. The other transmitter will be routed to the dummy load. Selection options are '1' (for TX 1) or '2' (for TX 2) (see below).

Enter your choice: t

Select the active TX (1 or 2) > 2  e.g., enter 2 for TX 2

VS Transfer Controller version 1.1.0.1

Main Menu

=====

F) Show Faults

M) Show Meters

C) Configure Thresholds

T) Set Active Transmitter (TX2) 

New setting displayed upon
return to Main Menu

A) Set Active Audio Source (MAIN)

X) Set RF Transfer Mode (MANUAL)

Y) Set Audio Transfer Mode (MANUAL)

N) Set Maintenance Mode (NORMAL)

R) Turn RF On/Off (RF ON)

D) Restore Factory Defaults

E) Reset CPU into NCodeUploader mode

Q) Quit

Enter your choice:

SET ACTIVE AUDIO SOURCE SUB-MENU

When you enter A (or a) as your choice in the Main Menu (see [Figure 3.33 on page 3.35](#)), you can set the active audio source that will be applied to the transmitters. Selection options are '1' (for main AES source) or '2' (for backup AES source) (see below).

Enter your choice: a
Select the Main (1) or Backup (2) audio source > 2  e.g., enter 2 for BACKUP

VS Transfer Controller version 1.1.0.1

Main Menu

=====

- F) Show Faults
- M) Show Meters
- C) Configure Thresholds
- T) Set Active Transmitter (TX2)
- A) Set Active Audio Source (BACKUP) 
- X) Set RF Transfer Mode (MANUAL)
- Y) Set Audio Transfer Mode (MANUAL)
- N) Set Maintenance Mode (NORMAL)
- R) Turn RF On/Off (RF ON)
- D) Restore Factory Defaults
- E) Reset CPU into NCodeUploader mode
- Q) Quit

New setting displayed upon return to Main Menu

Enter your choice:

SET RF TRANSFER MODE SUB-MENU

When you enter X (or x) as your choice in the Main Menu (see [Figure 3.33 on page 3.35](#)), you can enable or disable the automatic RF transfer mode for the system. Selection options are 'y' (to enable automatic RF transfer) or 'n' (to disable automatic RF transfer; i.e., manual transfer mode) (see below).

```
Enter your choice: x
Enable automatic RF transfer (y or n) > y ← e.g., enter y to enable
```

```
VS Transfer Controller version 1.1.0.1
```

```
Main Menu
```

```
=====
```

```
F) Show Faults
M) Show Meters
C) Configure Thresholds
T) Set Active Transmitter (TX2)
A) Set Active Audio Source (BACKUP)
X) Set RF Transfer Mode (AUTO) ← New setting displayed upon
Y) Set Audio Transfer Mode (MANUAL) ← return to Main Menu
N) Set Maintenance Mode (NORMAL)
R) Turn RF On/Off (RF ON)
D) Restore Factory Defaults
E) Reset CPU into NCodeUploader mode
Q) Quit
```

```
Enter your choice:
```

In AUTO mode, the main transmitter is on-air unless its RF output falls below a preset threshold for longer than a preset delay (0 to 300 s). This causes an RF transfer and the standby transmitter becomes the on-air transmitter. The low RF output threshold is set using the transmitters in the UI's User Settings -> Fwd Low screen. The RF transfer delay is set using the transmitters in the UI's System Settings -> Transfer Ctrl -> RF Chg Dly screen (see [Setting the RF Changeover Delay, on page 3.31](#)) or using a terminal program via the CONSOLE port (see [RF Changeover Delay, on page 3.40](#)).

In MANUAL mode, the active transmitter is on-air and there is no automatic changeover.

SET AUDIO TRANSFER MODE SUB-MENU

When you enter Y (or y) as your choice in the Main Menu (see [Figure 3.33 on page 3.35](#)), you can enable or disable the automatic AES audio transfer status for the system. Selection options are 'y' (to enable automatic audio transfer) or 'n' (to disable automatic audio transfer; i.e., manual transfer mode) (see below).

```
Enter your choice: y
Enable automatic audio transfer (y or n) > y ← e.g., enter y to enable
```

```
VS Transfer Controller version 1.1.0.1
```

```
Main Menu
```

```
=====
```

```
F) Show Faults
M) Show Meters
C) Configure Thresholds
T) Set Active Transmitter (TX2)
A) Set Active Audio Source (BACKUP)
X) Set RF Transfer Mode (AUTO)
Y) Set Audio Transfer Mode (AUTO) ← New setting displayed upon
N) Set Maintenance Mode (NORMAL) ← return to Main Menu
R) Turn RF On/Off (RF ON)
D) Restore Factory Defaults
E) Reset CPU into NCodeUploader mode
Q) Quit
```

```
Enter your choice:
```

In AUTO mode, the main AES audio is active unless its amplitude falls below a preset threshold for longer than a preset delay period (see [Setting the AES Changeover Delay, on page 3.23](#)). This causes an audio transfer and the backup audio becomes active. The system will return to the main AES source if the main AES level is above the preset return level for longer than the preset return delay period (see [AES Return Threshold:, on page 3.40](#) and [AES Return Delay:, on page 3.39](#)).

In MANUAL mode, the selected audio is active and there is no automatic changeover.

SET MAINTENANCE MODE SUB-MENU

When you enter N (or n) as your choice in the Main Menu (see [Figure 3.33 on page 3.35](#)), you can enable or disable the RF output of the transmitter being routed to the dummy load. This is typically enabled to allow maintenance or testing of the standby, or off-air transmitter. Selection options are 'y' (to enable standby operation into the dummy load; i.e., MAINTENANCE mode) or 'n' (to disable standby operation into the dummy load; NORMAL mode) (see below).

```
Enter your choice: y
Enable (y) or Disable (n) standby TX > y ← e.g., enter y to enable
```

```
VS Transfer Controller version 1.1.0.1
```

```
Main Menu
```

```
=====
```

```
F) Show Faults
M) Show Meters
C) Configure Thresholds
T) Set Active Transmitter (TX2)
A) Set Active Audio Source (BACKUP)
X) Set RF Transfer Mode (AUTO)
Y) Set Audio Transfer Mode (AUTO)
N) Set Maintenance Mode (MAINTENANCE) ← New value displayed upon
R) Turn RF On/Off (RF ON) return to Main Menu
D) Restore Factory Defaults
E) Reset CPU into NCodeUploader mode
Q) Quit
```

```
Enter your choice:
```

TURN RF ON/OFF SUB-MENU

When you enter R (or r) as your choice in the Main Menu (see [Figure 3.33 on page 3.35](#)), you can enable or disable the RF power stage of the active transmitter. When in remote mode, this is the equivalent of using the front panel RF On and RF off push-buttons. Selection options are 'y' (for RF On) or 'n' (for RF Off) (see below).

```
Enter your choice: r
Turn RF On (y) or Off(n) > n ← e.g., enter n for RF Off
```

```
VS Transfer Controller version 1.1.0.1
```

```
Main Menu
```

```
=====
```

```
F) Show Faults
```

```
M) Show Meters
```

```
C) Configure Thresholds
```

```
T) Set Active Transmitter (TX2)
```

```
A) Set Active Audio Source (BACKUP)
```

```
X) Set RF Transfer Mode (AUTO)
```

```
Y) Set Audio Transfer Mode (AUTO)
```

```
N) Set Maintenance Mode (MAINTENANCE) ←
```

```
R) Turn RF On/Off (RF OFF)
```

```
D) Restore Factory Defaults
```

```
E) Reset CPU into NCodeUploader mode
```

```
Q) Quit
```

New value displayed upon
return to Main Menu

```
Enter your choice:
```

NOTE: The VS-TC sends 'RF mute' commands to the transmitters to enable or disable their RF outputs. Both transmitters must be configured for RF On to operate in the main-standby system.

RESTORE FACTORY DEFAULTS SUB-MENU

When you enter D (or d) as your choice in the Main Menu (see [Figure 3.33 on page 3.35](#)), you can restore the VS-TC to its factory default state. Selection options are 'y' (to restore) or 'n' (to maintain current settings) (see below).

```
Enter your choice: d
Restore factory defaults (y or n) > y ← e.g., enter y to restore
                                       factory defaults

VS Transfer Controller version 1.1.0.1

Main Menu
=====
F) Show Faults
M) Show Meters
C) Configure Thresholds
T) Set Active Transmitter (TX1)
A) Set Active Audio Source (MAIN)
X) Set RF Transfer Mode (MAN)
Y) Set Audio Transfer Mode (MAN)
N) Set Maintenance Mode (NORMAL)
R) Turn RF On/Off (RF OFF)
D) Restore Factory Defaults
E) Reset CPU into NCodeUploader mode
Q) Quit
```

Enter your choice:

Default thresholds settings are as follows:

- ❖ AES Changeover Delay = 300.0 s
- ❖ AES Changeover Threshold = -60.0 dBFS
- ❖ AES Return Delay = 300.0 s
- ❖ AES Return Threshold = -60.0 dBFS
- ❖ RF Changeover Delay = 300.0 s

RESET CPU INTO NCodeUPLOADER MODE SUB-MENU

When you enter E (or e) as your choice in the Main Menu (see [Figure 3.33 on page 3.35](#)), you can reset the VS-TC's CPU into NCodeUploader mode. This is typically done to perform a firmware (software) upgrade to the VS-TC. Selection options are 'y' (to proceed) or 'n' (to return to the Main Menu) (see below).

NOTE: Proceeding with this function will take the transmitter system off-air.

```
Enter your choice: e
```

```
The system will be off-air while this unit's firmware is upgraded.  
Proceed (y or n) > n
```

```
VS Transfer Controller version 1.1.0.1
```

e.g., enter n to cancel
and return to Main Menu

```
Main Menu
```

```
=====
```

```
F) Show Faults  
M) Show Meters  
C) Configure Thresholds  
T) Set Active Transmitter (TX2)  
A) Set Active Audio Source (BACKUP)  
X) Set RF Transfer Mode (AUTO)  
Y) Set Audio Transfer Mode (AUTO)  
N) Set Maintenance Mode (MAINTENANCE)  
R) Turn RF On/Off (RF OFF)  
D) Restore Factory Defaults  
E) Reset CPU into NCodeUploader mode  
Q) Quit
```

```
Enter your choice:
```

Selecting 'y' to proceed will disable the transmitter system's RF output and enter the terminal program into NCodeUploader mode, where you can perform a firmware update. See [Upgrading Firmware, on page 3.49](#) for more details.

Upgrading Firmware

This section provides instructions to upgrade the firmware on the VS-TC's transfer control PWB.

Requirements

To perform an upgrade you will need:

- USB cable (Nautel Part # UB98, provided in the ancillary kit)
- PC or laptop with a terminal program installed such as PuTTY or Teraterm. (this procedure assumes PuTTY is installed)
- The latest version of NCodeUploader.exe installed. If necessary, download it from:

<ftp://www3.nautel.com/Utilities/NCodeUploader/>

Procedure

Perform the following steps to upgrade the firmware:

1. Connect the USB cable (Nautel Part # UB98) between the CONSOLE USB port on the front panel of the VS-TC and an available USB port on a PC or laptop. If necessary, follow normal Windows Update procedures to install a driver for the USB device.
2. Determine the COM port number that has been assigned to the USB connection.
 - ❖ Open the Control Panel Device Manager. The exact procedure will vary depending on the version of Windows you are using.
 - ❖ Expand the Ports (COM & LPT) section.
 - ❖ Note the COM port identified as "USB Serial Port". In the example shown in [Figure 3.31 on page 3.34](#), it is COM10.
3. Open the PuTTY serial terminal program. Set the Connection Type to Serial.
4. See [Figure 3.32 on page 3.34](#). Enter the COM port number identified in [Step 2](#) in the Serial line field (e.g., COM10). Enter 115200 in the Speed field. Click Open. The screen in [Figure 3.34 on page 3.50](#) should appear.

Figure 3.34: Serial Menu Console Screen

```
COM10 - PuTTY
Type "erialmenu" to enter the menu
Type "rialmenu" to enter the menu
Type "ialmenu" to enter the menu
Type "almenu" to enter the menu
Type "lmenu" to enter the menu
Type "menu" to enter the menu
Type "enu" to enter the menu
Type "nu" to enter the menu
Type "u" to enter the menu

VS Transfer Controller version 1.0.0.9

Main Menu
=====
F) Show Faults
M) Show Meters
C) Configure Thresholds
T) Set Active Transmitter (TX1)
A) Set Active Audio Source (BACKUP)
X) Set RF Transfer Mode (MANUAL)
Y) Set Audio Transfer Mode (MANUAL)
N) Set Maintenance Mode (NORMAL)
R) Turn RF On/Off (RF OFF)
D) Restore Factory Defaults
E) Reset CPU into NCodeUploader mode
Q) Quit

Enter your choice: e

The system will be off-air while this unit's firmware is upgraded.
Proceed (y or n) > y

Entering NCodeUploader mode.
Please wait...
Ncod?üääää
```

5. Type "serialmenu" (without the quotes) to activate the console.
6. From the Main Menu, type 'E' and press Enter.
7. Type 'Y' and press Enter to confirm you want to proceed. You should see the message "Entering NCodeUploader mode. Please wait..."
8. Close PuTTY. A dialog box will ask if you want to close the session. Click OK to continue.
9. Run NCodeUploader.exe. The screen in [Figure 3.35 on page 3.51](#) will display.
10. Click the Settings button in the top right corner to set up the serial port. The screen in [Figure 3.36 on page 3.51](#) will display.
11. See [Figure 3.36 on page 3.51](#). Ensure the serial port selected in the drop down box is correct for your computer. Ensure the checkbox for 'Use debugging dialog' is unchecked. Ensure the checkbox for 'Attempt high speed programming' is checked. Click OK to apply the settings and go back to the main dialog.
12. In the main dialog of the NCodeUploader program (see [Figure 3.35 on page 3.51](#)), click the Upload DSP Firmware button. After a brief pause, the screen in [Figure 3.37 on page 3.52](#) will display.
13. Click OK to proceed to the programming dialog. You may receive a message about loading files. Click OK again. The screen in [Figure 3.38 on page 3.52](#) will display.

Figure 3.35: NCodeUploader Main Screen

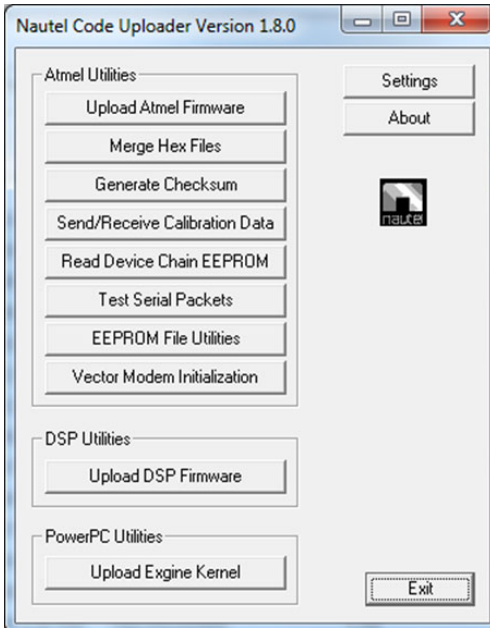

Figure 3.36: NCodeUploader - Settings Screen

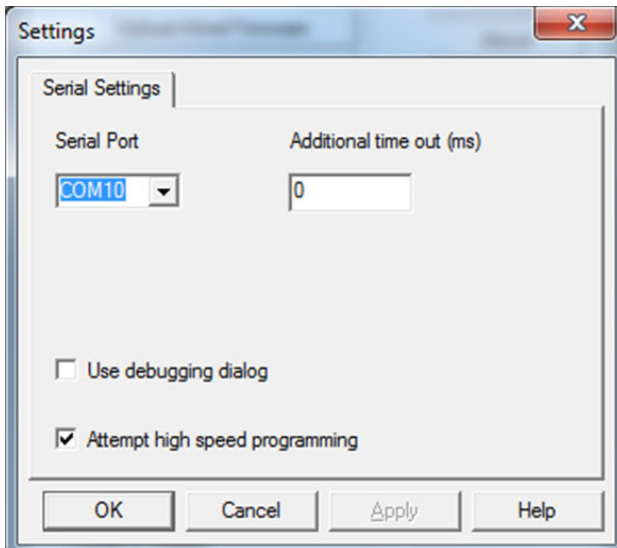

Figure 3.37: NCodeUploader - Successful Connection Screen

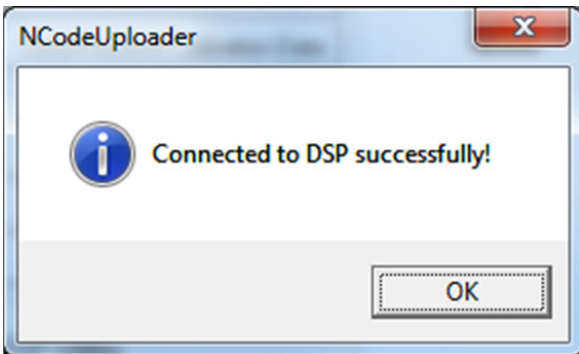
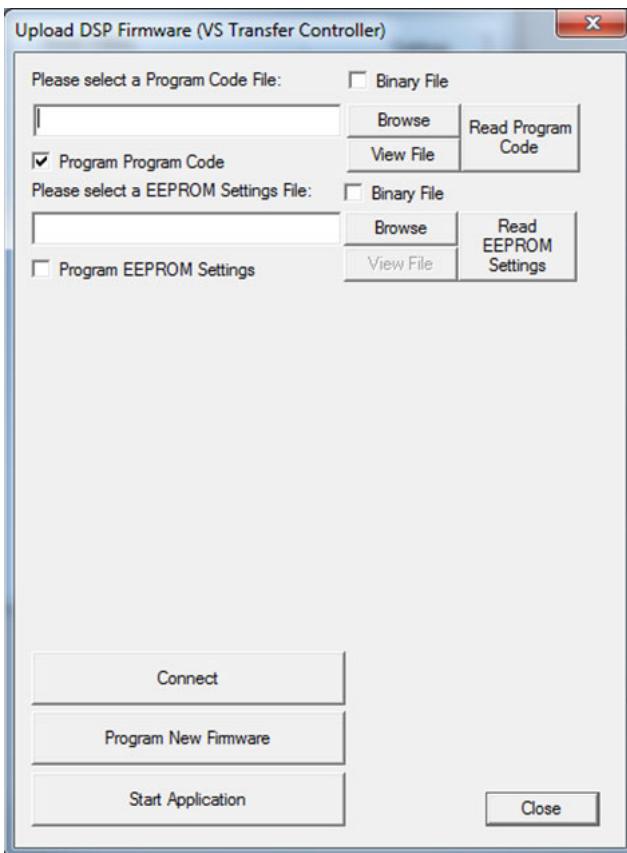
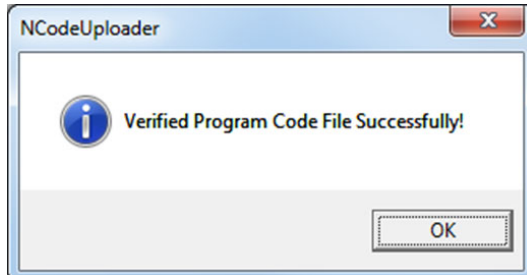

Figure 3.38: Upload DSP Firmware Screen



14. Ensure the checkboxes are checked exactly as shown in [Figure 3.38 on page 3.52](#). Click the Browse button for the Program Code File. Select the file, which will have the naming convention VS-TC_NAPC166_VX.Y.Z.A.hex.
 - ❖ X.Y.Z.A gives the version number to be programmed.
 - ❖ Do not select the file with the word "merged" at the end of the filename.
15. Upon successful loading of the file, the screen in [Figure 3.39](#) will display. Click OK.

Figure 3.39: Successful Verification of Program Code



16. See [Figure 3.38 on page 3.52](#). Click Program New Firmware to proceed with the upgrade. A progress bar (see [Figure 3.39](#)) will display and move from 0 to 100%. Wait for this to complete.

Figure 3.40: Program New Firmware - Progress Bar

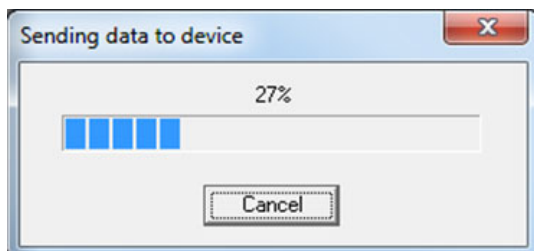

17. Upon successful upgrade, the screen in [Figure 3.41](#) will display. Click OK to return to the screen in [Figure 3.38 on page 3.52](#).

Figure 3.41: Successful Firmware Upgrade

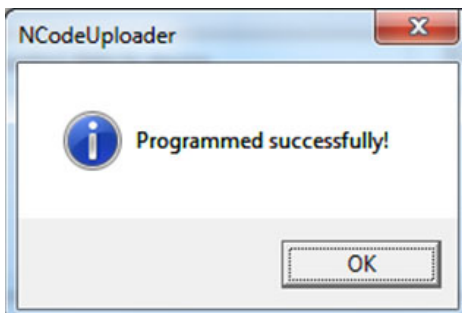

18. See [Figure 3.38 on page 3.52](#). Click Start Application. The screen in [Figure 3.42](#) will display. The front panel LEDs on the VS-TC should turn on after a few seconds. Click OK.

Figure 3.42: NCode Uploader DSP Operational

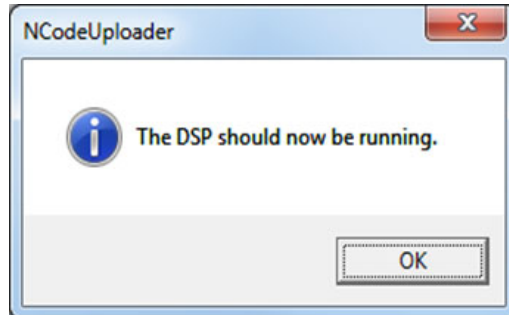

19. Close NCodeUploader and remove the USB cable. The firmware upgrade is complete. The VS-TC may need a few seconds to reboot.

SECTION 4: TROUBLESHOOTING

NOTE: It is highly recommended that troubleshooting personnel be familiar with the operation of the . Refer to the Operating section of this manual as an aid in troubleshooting.

This section contains information intended to aid in responding to faults with the VS-TC, including:

- [Identifying a Fault - see page 1.4.1](#)
- [Types of Faults - see page 1.4.2](#)
- [Checking Cable Connections - see page 1.4.4](#)

The remaining sections of this manual contain theory of operation, parts lists, electrical schematics and mechanical drawings that may also assist in troubleshooting or repairing the VS-TC.

Identifying a Fault

There are several ways to monitor the VS-TC's operational status and determine if a fault is occurring:

- Check the Alarms menu of the associated transmitters' front panel UI. See the associated transmitter's documentation for more information on navigating its front panel UI. The VS-TC related alarms are also listed in [Table 4.1 on page 4.2](#).

NOTE: With the exception of the alarms listed in [Table 4.1 on page 4.2](#), the associated transmitters have their own separate fault list, which are beyond the scope of this manual. Refer to the transmitter's Troubleshooting Manual for instructions on responding to transmitter related alarms.

- Check the Show Faults menu of a terminal program (e.g., PuTTY) on a PC or laptop that is connected to the CONSOLE port on the front panel of the VS-TC. See the Operating section of this manual for details on using the terminal program interface and to [Table 4.1 on page 4.2](#) for a list of faults that may appear.
- Check the remote monitoring station, if applicable, that is connected using discrete wiring to the REMOTE I/O (A1J5) D-sub connector on the rear of the VS-TC. See [Table 2.2: Remote Alarm and Status Outputs, on page 2-9](#) in Section 2 of this manual for a list of status and alarm outputs that can be remotely monitored.

The options described above allow the user to determine the VS-TC's operational status at almost any time. In the event that the VS-TC becomes non-operational, some simple troubleshooting procedures can be followed to return it to operational status. This section outlines some common errors and warnings that may occur, along with the procedures to correct each problem.

Types of Faults

Table 4.1 lists the VS-TC faults that may appear on any of the local or remote monitoring methods described in [Identifying a Fault, on page 4.1](#), as well as brief descriptions and suggested troubleshooting action.

NOTE: Faults are listed alphanumerically. The displayed fault name may vary slightly between the Alarms screen on the transmitter front panel UI and the Show Faults list in the terminal program.

Table 4.1: List of Faults

Fault	Description and Troubleshooting Action
AES Changeover	This fault occurs when an automatic AES transfer has occurred. The AES audio source designated as MAIN is no longer feeding the transmitters and the BACKUP AES source is active.
Bkup AES Low	This fault occurs when the backup AES audio level is less than the AES Changeover Threshold. May also be accompanied by a Bkup AES Unlock fault (see its description and troubleshooting action). If no accompanying alarm exists, suspect a problem with the external audio processor or studio feed. This fault is active regardless of the automatic AES transfer state (enabled or disabled).
Bkup AES Unlock	This fault occurs when the main AES cable is not connected. This fault is active regardless of the automatic AES transfer state (enabled or disabled). Check the main AES feed.
Main AES Low	This fault occurs when the main AES audio level is less than the AES Changeover Threshold. May also be accompanied by a Main AES Unlock fault (see its description and troubleshooting action). If no accompanying alarm exists, suspect a problem with the external audio processor or studio feed. This fault is active regardless of the automatic AES transfer state (enabled or disabled).
Main AES Unlock	This fault occurs when the main AES cable is not connected. This fault is active regardless of the automatic AES transfer state (enabled or disabled). Check the main AES feed.
Relay Intlk Open	This fault occurs when the RF coaxial transfer switch interlock did not close after the last changeover. Check the switch operation.
Relay Pos Fail	This fault occurs when the position indicator of the RF coaxial transfer switch (S1) did not move to the desired transmitter after the last changeover. Attempt to perform a manual changeover. Check the switch operation.
RF Changeover	This fault occurs when an automatic RF transfer has occurred. The VS transmitter designated as MAIN is now operating into the dummy load and the BACKUP transmitter is on air. The alarm will clear if the main transmitter recovers from its fault or if the main transmitter state is modified manually.

Fault	Description and Troubleshooting Action
Sys Intlk Open	This fault occurs if the external system interlock circuit is open. Check all external interlocks connected to the VS-TC.
TX 1 Comm Fail	This fault occurs if TX 1 has not communicated with the VS-TC within the past two (2) seconds. This fault is active regardless of the automatic RF transfer state (enabled or disabled).
TX 1 Failure	This fault occurs if either the TX 1 Comm Fail or TX 1 Output Low fault is occurring. This fault is active regardless of the automatic RF transfer state (enabled or disabled). The alarm clears when both of the above conditions are cleared or when the automatic RF transfer state is manually modified.
TX 1 Output Low	This fault occurs if TX 1 experiences a Forward Power Low Alarm. This fault is active regardless of the automatic RF transfer state (enabled or disabled). Refer to the VS Troubleshooting Manual to respond to the fault.
TX 2 Comm Fail	This fault occurs if TX 2 has not communicated with the VS-TC within the past two (2) seconds. This fault is active regardless of the automatic RF transfer state (enabled or disabled).
TX 2 Failure	This fault occurs if either the TX 2 Comm Fail or TX 2 Output Low fault is occurring. This fault is active regardless of the automatic RF transfer state (enabled or disabled). The alarm clears when both of the above conditions are cleared or when the automatic RF transfer state is manually modified.
TX 2 Output Low	This fault occurs if TX 2 experiences a Forward Power Low Alarm. This fault is active regardless of the automatic RF transfer state (enabled or disabled). Refer to the VS Troubleshooting Manual to respond to the fault.
+15V Fail	This fault occurs if the +15 V supply on the transfer control PWB (A1) is outside of its acceptable voltage range (between +13.5 V and +16.5 V).
+1.8V Fail	This fault occurs when the +1.8 V supply is below 1.62 V (90%). The fault clears when the +1.8 V supply level exceeds 1.71 V (95%).
+24V A Fail	This fault occurs when 24 V dc supply A level is below 21.6 V (90%). The fault clears when 24 V supply A level exceeds 22.8 V (95%).
+24V B Fail	This fault occurs when 24 V dc supply A level is below 21.6 V (90%). The fault clears when 24 V supply A level exceeds 22.8 V (95%).
+3.3V Fail	This fault occurs when the +3.3 V supply is below 2.97 V (90%). The fault clears when the +3.3 V supply level exceeds 3.13 V (95%).

Checking Cable Connections

Verify that the VS-TC's internal cables are connected properly as follows:

1. Remove the VS-TC's top cover.
2. Inspect the cables and connections. If a connector is unseated or disconnected, reconnect it to its mate as identified in [Table 4.2](#).
3. Reinstall the VS-TC's top cover.

Table 4.2: Connector Mating Information

Connector	Mate
W1P1	A1J10
W1P2	U1J1
W2P1	A1J11
W2P2	A2J2

SECTION 5: THEORY OF OPERATION

This section contains theory of operation for the VS-TC Transfer Controller and the main-standby transmitter system. Frequency reference is made to electrical schematics (SD-#s), which are located in [Section 7, "Electrical Schematics"](#) of this manual.

Topics in this section include:

- [System Overview](#)
- [Power Loss and Recovery, on page 5.2](#)
- [VS-TC Transfer Controller, on page 5.2](#)

System Overview

See electrical schematic Figure SD-1 (for VS150C systems), SD-2 (for VS300 systems), or SD-3 (for VX150 to VX600 transmitters). The VS-TC (A1) is the controlling interface between a pair of FM broadcast transmitters (A2 and A3) connected in a main-standby arrangement. The VS-TC controls the ON/OFF state of the RF power stages of both transmitters by interrupting their interlock (RF mute) circuits and causing an RF on/off command.

The VS-TC allows local or remote selection of the transmitter to be designated as the main (on-air) transmitter. In operation, an internal RF coaxial switch (A1U1) routes the RF output of the main transmitter to the antenna system and routes the RF output of the standby transmitter to the station test load. The standby transmitter's RF mute circuit will be activated and its RF power stage will be turned off unless the override option is selected locally by setting the front panel MODE switch to the MAINTENANCE position.

Provision is also made to apply a main and a backup program source. Under normal operating conditions the main source provides program to both transmitters. If the main program source fails and the system was set for automatic audio transfer, the VS-TC will initiate a changeover to the backup program source. Recovery of the main program source will automatically restore it as the active program.

The VS-TC has provision to set various thresholds that control RF transfer and audio transfer. You can set a threshold and a delay period for the automatic AES audio transfer function. You can also set a delay period for the RF transfer control function. The RF transfer threshold is linked to the transmitter's 'Low Fwd Pwr Alarm'. See [Section 3, "Operating Instructions"](#) for more detailed information on these settings.

VS-TC to VX Serial Converter Assembly (Units 4 and 5)

For each VX150 to VX600 transmitter used in a system, a VS-TC to VX serial converter assembly (Units 4 and 5, if applicable, see electrical schematic Figure SD-3) is installed between the appropriate XMTR LINK port(s) on the VS-TC and the XMTR LINK port(s) on the VX transmitter(s). This assembly performs a serial RS485-to-RS422 conversion to allow connection compatibility for the VX transmitter(s).

Power Loss and Recovery

All audio and RF transfer settings are stored in non-volatile memory allowing the system to recover to the last known state in the event of a power loss to the VS-TC.

The recovery time to backup audio source depends on the audio transfer delay when in auto transfer mode only. If the backup audio source has become active in AUTO audio transfer mode (due to a main audio source failure) and a power loss occurs, upon power recovery the audio source will default to the MAIN audio source input, then transfer to BACKUP audio source after the programmed audio transfer delay if the MAIN audio source level is still below the main audio transfer threshold.

VS-TC Transfer Controller

See electrical schematic Figure SD-4. Components in the VS-TC control the routing of the RF output of each transmitter. The output of one transmitter is routed to the antenna. The output of the other transmitter is routed to the test load. The VS-TC contains the transfer control PWB (A1), the button/LED PWB (A2) and the RF coaxial transfer switch (U1).

Transfer Control PWB (A1)

See electrical schematics Figure SD-4 and SD-5 through SD-7.

The transfer control PWB controls the operation of the VS-TC. Its functions include:

- Interfaces with all remote inputs and outputs by accepting operational commands and providing the appropriate status signals. Remote interface connections are made to the REMOTE I/O (A1J5) D-sub connector on the rear panel.
- Interfaces with the front panel push-buttons to interpret local commands and provide the appropriate LED status signal.
- Controls the position of the RF coaxial transfer switch (A1U1) by monitoring local commands from the front panel switches and remote commands from the rear panel interface.

- Accepts the main and backup program input sources and monitors the main input to ensure it maintains an acceptable level. During normal operation, the main program input source will be split to provide the program inputs for both transmitters A and B. If the main program input source falls below a user-established threshold, a circuit will initiate a changeover to the backup source. Audio connections are made to the AES IN MAIN (A1J6) and AES IN BACKUP (A1J7) XLR connectors on the rear panel.
- Accepts and monitors the user-provided system interlock input applied to SYSTEM INTERLOCK (A1J4) connector on the rear panel. If a short circuit exists between terminals 1 and 2 and +15 V dc is applied to A1J5-5, the interlock is intact and the transmitter system will operate as expected. If an open circuit exists - indicative of a compromised external interlock circuit - the RF output of both transmitters will be inhibited.
- Provides communication with the transmitters via serial bus connections. This interface provides control and status information from each transmitter using Tx Data, Rx Data and ground lines. Serial connections are made to the XMTR LINK TX1 (A1J3A) and XMTR LINK TX2 (A1J3B) connectors on the rear panel.
- Accepts +24 V dc from each transmitter (for VS150C systems) or from ac-dc power supplies (for VS300, VX150 to VX600, and stand-alone systems) as the power source for the VS-TC. The 24 V dc inputs are ORed and converted to various low level dc supplies (15 V, 3.3 V, 2.5 V and 1.8 V) used throughout the VS-TC. Only one 24 V dc input is required for operation. If operating the VS-TC with VS300 or VX150 to VX600 transmitters, or without a transmitter, one or two external ac-dc power sources are required. The ancillary kit provides two +24 V dc power supplies (Nautel Part # **UG116**) and two ac line cords (Nautel Part # JN25) to facilitate this purpose.

Button/LED PWB (A2)

See electrical schematics Figures SD-4 and SD-8. The button/LED PWB provides the local control and monitoring peripheral for the system. It contains push-button switches that select the local/remote control mode, the RF transfer control mode (automatic or manual), the main transmitter (TX 1 or TX2), the standby transmitter's operational mode [normal (inhibited) or maintenance (operational)], the audio transfer control mode (automatic or manual), the active audio source (main or backup) and the RF on/off status of the system. It also contains LEDs that indicate the status of the switch selections and the RF routing status of the transmitters (to antenna and test load). All switches and LEDs protrude through the VS-TC's front panel.

The CONSOLE port provides a means to connect serially (USB to RS-232 interface) to the VS-TC. This allows the ability, using a terminal program (e.g., PuTTY), to configure the VS-TC.

Input power (+3.3 V dc) is provided by transfer control PWB (A1).

Refer to [Section 3, "Operating Instructions"](#) for more detailed information on button, LED and CONSOLE port functions.

RF Coaxial Transfer Switch (U1)

See electrical schematics Figure SD-1 through SD-4. The RF coaxial transfer switch (U1) provides a means to route the RF outputs of the two transmitters to the antenna system or the test load. The transfer control PWB (A1) uses local controls from the front panel or remote controls applied to the rear panel to determine the position of the switch (position 1 = transmitter 1 to antenna, transmitter 2 to test load; position 2 = transmitter 2 to antenna, transmitter 1 to test load).

TRANSMITTER 1 TO ANTENNA OPERATION. When transmitter 1 to antenna operation is selected, the transfer control PWB applies 24 V to the RF coaxial transfer switch's + POS1 input (U1J1-1). The RF coaxial switch will be configured for position 1 and the output of transmitter 1 will be routed to the antenna (directional coupler) via port 1. The output of transmitter 2 will be routed to the test load via port 4.

TRANSMITTER 2 TO ANTENNA OPERATION. When transmitter 2 to antenna operation is selected, the transfer control PWB applies 24 V to the RF coaxial transfer switch's + POS2 input (U1J1-3). The RF coaxial switch will be configured for position 2 and the output of transmitter 2 will be routed to the antenna (directional coupler) via port 1. The output of transmitter 1 will be routed to the test load via port 4.

RF COAXIAL SWITCH INTERLOCKS. A micro-switch within the RF coaxial transfer switch opens and closes as required to ensure that RF power is disabled during a switch transfer and that RF power is re-enabled when the transfer is complete and the switch is in the correct position.

POSITION 1 AND 2 INDICATORS. A micro-switch within the RF coaxial transfer switch alternates contacts as required to provide a contact closure that indicates that the switch is in position 1 (TX 1 to air) or position 2 (TX 2 to air). A fault occurs if the indicated switch position is not the same as the desired switch position.

SECTION 6: PARTS LIST

This section contains reference designation lists that provide descriptive and provisioning information for all electrical and mechanical parts that have an assigned reference designation and form a part of the subject equipment.

Topics in this section include

- [How to Locate Information About a Specific Part](#)
- [Column Content](#)
- [Common Abbreviations/Acronyms on page 6.2](#)

How to Locate Information About a Specific Part

To locate the information for a specific part, the assigned reference designation for the part must be known. In addition, the Nautel nomenclature (e.g., NAX271B) assigned to the assembly containing the part or the full reference designation, including the reference designation of all higher assemblies, must be known.

Column Content

The following paragraphs provide an explanation of the purpose and contents of each column in the reference designation lists.

Component Level, Stock Code Column

This column contains the *Component Level* number (01 through 10, as required) and the Nautel *Stock Code* (part number) assigned to each part.

Component Level

This number represents the level of a component in relation to the highest level parts list. In this case the highest level parts list is the VS-TC's overall parts list.

Components that are directly descended from the highest level parts list are component level 01. The associated stock code and description for level 01 items appear in bold text in the reference designation list, followed by their sub-assembly components, as applicable. Level 01 items are sorted alphanumerically.

Components that are directly descended from component level 01 items are component level 02. The associated stock code and description for level 02 items appear below their associated level 01 component, slightly indented, followed by their sub-assembly components, as applicable. Level 02 items are sorted alphanumerically.

Component level 03 through 10 items, as applicable, descend similarly to component level 02 items, with continuing indentations to identify each new level.

Stock Code

This number is Nautel's drawing number for Nautel manufactured parts, Nautel's configuration control number for assemblies that are under configuration control management, or Nautel's inventory management number for purchased parts. When a Nautel configuration control number (e.g. NAPC*) is shown in this column, its sub-assembly reference designation items are listed below it.

Description Column

This column contains the name and descriptive information for each part. The key word is presented first, followed by the adjective identifiers.

Reference Designation Column

This column contains the reference designation(s) for a specific part. When multiple reference designations apply to a part, they are sorted alphanumerically. These designations are assigned in accordance with the requirements of IPC-2612-2010 - Sectional Requirements for Electronic Diagramming Documentation (Schematic and Logic Descriptions).

Common Abbreviations/Acronyms

The following abbreviations/acronyms may appear in the Description of Part column:

- SMT: Denotes item is designed to be installed using Surface Mount Technology.
- MTA: Denotes item is a Mass Termination Assembly connector.
- SIP: Single In-line Package
- DIP: Dual In-line Package
- IDC: Denotes item is an Insulation Displacement connector for ribbon cable.

StockCode: 235-5650-01

Page 1 of 5

Description: VS-TC to VX Serial Converter Assy,

<u>Component Lvl.</u>	<u>StockCode</u>	<u>Description</u>	<u>Reference Designation</u>
01	235-5652-02	VS-TC to VX Serial Adapter Assy (RS422)	A01
01	235-5652-03	VX to VS-TC Serial Adapter Assy (RS485)	A02
01	JT263	Conn, Gender Changer, D-Sub, M/M, 9 Pin	U02
01	UA180	Cable Cat6E, 5ft, Shld, Blue, 26AWG, 75degC, nogua	W01, W02
01	UH326	Converter, Serial to Serial, RS485/RS422, D-Sub, M	U01
		END OF ITEM	

StockCode: NAX271B

Description: Transfer Control Assy, (VS-TC),

<u>Component Lvl.</u>	<u>StockCode</u>	<u>Description</u>	<u>Reference Designation</u>
01	230-5004	CableSet Assy - Transfer Controller	
02	JP51	Conn, Recept, Ribbon Cable, 40 pin	W2P1, W2P2
02	UA247	Cable, D-sub, 9-pin, M/F, Mold ed, 1ft	W01
01	230-8005-02	Ancillary Kit, VS-TC	
02	198-5025-01	Panel Screw Kit	
02	230-5024-01	RF Interface Cable Assy	
02	230-5025	Remote I/O 15V Jumper Conn Assy	
01	KC96	Relay, RF Coaxial, Transfer, 4-Port, 24Vdc, N-F	U01
01	NAPC166A	Transfer Control PWB Assy	A01
02	CCFS04	Cap,SMT,Ceramic,0.01uF,10%,50V,X7R,0603	C045, C048, C049, C050, C053, C054, C057, C060, C061, C062, C063, C064, C066, C067, C068, C070,, C071, C072, C073, C074, C075, C076, C077, C080, C081, C082, C084, C085, C087, C088, C089, C094,, C095, C096, C102
02	CCFS10	Cap,SMT,Ceramic,1uF,10%,25V,X7R,1206	C043, C046
02	CCFS23	Cap,SMT,Ceramic,18pF,2%,50V, C0G,0603	C018, C020
02	CCFS52	Cap, SMT, Ceramic, 0.1uF, 10%, 25V X7R, 0603	C002, C003, C004, C005, C006, C007, C008, C009, C010, C011, C012, C013, C014, C015, C016, C017,, C019, C022, C023, C024, C025, C026, C027, C028, C029, C030, C031, C032, C033, C034, C035, C036,, C037, C038, C039, C040, C041, C042, C044, C047, C051, C052, C055, C056, C058, C059, C065, C069,, C078, C079, C083, C086, C092, C100
02	CCFS53	Cap, SMT, Ceramic,47uF,20%, 6.3V, 1210	C001
02	CCFS57	Cap,SMT,Ceramic,10uF,20%,6.3V, X5R,0805	C021
02	CCFS72	Cap, SMT, Ceramic, 10uF, 10%, X7R, 50V, 2220	C093, C101
02	CT68	Cap, SMT, Electrolytic, 68uF, 20%, 63V	C097, C103
02	CTFS04	Cap,SMT,Tantalum,100uF,10%,10V,2917	C098, C099
02	CTFS07	Capacitor, SMT, Tantalum, 100uF, 10%, 20V, 2917	C090, C091
02	H AJ66	Terminal, SMT, Test Point, PWB	TP01, TP02

StockCode: NAX271B

Page 3 of 5

Description: Transfer Control Assy, (VS-TC),

<u>Component Lvl.</u>	<u>StockCode</u>	<u>Description</u>	<u>Reference Designation</u>
02	JF47	Conn, Header,Square Post,Gold, Dual,40-pin	J12
02	JQ15	Conn, Post Shunt, 2 Pos, .10 C entreline	E01
02	JQ16	Conn, Header, SIP, 12 Pin Breakaway, 10 Ctr	XE01
02	JQ34	Conn, Socket, D-Sub, 9 pin, PW B Mt	J10
02	JQ53	Conn, Header, Ribbon Cbl, 40- Pin	J11
02	JR51	Terminal Block,2-pos,PWB Mount	J04
02	JS13	Conn, Socket, D-Sub, 25 pin, P WB Mt	J05
02	JT171	Conn, Jack, Twist-Lock, 2.5x 5.7mm, 5A, RA PWB Mou	J01, J02
02	JT77	Connector,Modular,Dual,RJ-45 Jack Rt Agl, PWB	J03
02	JT87	Conn,3-pin,PWB Mount, Fem, XLR	J06, J07
02	JT88	Conn,3-pin,PWB Mount,Male,XLR	J08, J09
02	LCFS01	Inductor, SMT, Choke, 600ohms, 2A, 0805	L01, L02
02	LS22	Choke,SMT,Common Mode,2200 ohm ,200mA,1206	L03, L04, L05, L06
02	LS35	Inductor, SMT, Shielded, DR Series, 15uH, 4A RMS	L07, L08, L09, L10
02	QBNS01	Transistor,SMT,NPN,Switch/Amp ,SOT-23	Q02, Q04
02	QDLS01	Diode, SMT, LED, Green, (560nm), 0603	DS02, DS03
02	QDLS07	Diode, SMT, LED, Amber, (592nm), 0603	DS01
02	QDRS01	Diode,SMT,Switching,250V,0.2A, SOD-323	CR01, CR02, CR03, CR05, CR06, CR07, CR09, CR10, CR11, CR12, CR13, CR14, CR15, CR16, CR17, CR18,, CR19, CR20, CR21, CR22, CR24
02	QDSS03	Diode, SMT, Shottky, 40V, 3A, SMA	CR23, CR25, CR26, CR27
02	QDZS04	Diode,SMT,Zener,39V,5%,3W,SMB	CR04, CR08
02	QR71	Transistor, FET, P-channel, D2Pak	Q01, Q03
02	RAD26	Resistor, SMT, MF, 1210 Ohms, 1% 1/4W	R030, R041, R044, R051, R053, R061, R063, R064, R073, R074, R075, R079, R087, R088, R089, R098,, R100, R110, R115, R119, R127
02	RAD69	Resistor, SMT, 590 Ohms, 1%, 1 W, 2512	R116, R117
02	RAE34	Resistor,SMT,MF,49.9R,1%,1/10W 0603	R097, R099, R106, R109
02	RFFS01	Resistor,SMT,MF,0.0ohms,Jumper ,0603	R013, R124, R140
02	RFFS15	Resistor, SMT, MF, 12.1ohms, 1%, 1/10W, 0603	R026, R031, R035, R040, R042, R046, R048, R052, R054, R056, R060, R062
02	RFFS18	Resistor, SMT, MF, 22.1ohms, 1%, 1/10W, 0603	R022
02	RFFS23	Resistor, SMT, MF, 56.2ohms, 1%, 1/10W, 0603	R118
02	RFFS26	Resistor, SMT, MF, 100ohms, 1%, 1/10W, 0603	R002, R003, R005, R006
02	RFFS27	Resistor, SMT, MF, 121ohms, 1%, 1/10W, 0603	R014, R017

StockCode: NAX271B

Page 4 of 5

Description: Transfer Control Assy, (VS-TC),

<u>Component Lvl.</u>	<u>StockCode</u>	<u>Description</u>	<u>Reference Designation</u>
02	RFFS28	Resistor, SMT, MF, 150ohms, 1%, 1/10W, 0603	R016, R133
02	RFFS29	Resistor,SMT,MF,182ohms,1%, 1/10W,0603	R091, R101
02	RFFS30	Resistor, SMT, MF, 221ohms, 1%, 1/10W, 0603	R001, R004
02	RFFS34	Resistor,SMT,MF,475ohms,1%, 1/10W,0603	R092, R094, R102, R105
02	RFFS37	Resistor, SMT, MF, 825ohms, 1%, 1/10W, 0603	R122
02	RFFS38	Resistor,SMT,MF,1000ohms,1%, 1/10W,0603	R023, R025, R036, R129, R135
02	RFFS39	Resistor,SMT,MF,1210ohms,1%, 1/10W,0603	R015, R021
02	RFFS41	Resistor,SMT,MF,1820ohms,1%, 1/10W,0603	R123
02	RFFS46	Resistor, SMT, MF, 4750ohms, 1%, 1/10W, 0603	R037, R039, R047, R050, R057, R059, R066, R068, R070, R071, R080, R081, R084, R085, R093, R095,, R103, R107, R112, R120, R125, R130, R131, R136, R141
02	RFFS49	Resistor,SMT,MF,8250ohms,1%, 1/10W,0603	R029, R034, R139
02	RFFS50	Resistor,SMT,MF,10.0Kohms,1%, 1/10W,0603	R007, R009, R011, R012, R018, R019, R028, R032, R033, R038, R043, R045, R049, R055, R058, R065,, R067, R069, R072, R076, R078, R082, R083, R086, R090, R096, R104, R108, R111, R113, R114, R121,, R126, R128, R132, R137
02	RFFS51	Resistor,SMT,MF,12.1Kohms,1%, 1/10W,0603	R020, R027, R134
02	RFFS54	Resistor,SMT,MF,22.1Kohms,1%, 1/10W,0603	R008
02	RFFS58	Resistor, SMT, MF, 47.5Kohms, 1%, 1/10W, 0603	R138
02	RFFS66	Resistor, SMT, MF, 221Kohms, 1%, 1/10W, 0603	R010
02	RX62	Thermistor, PTC, SMT, 1206, 1.5-6 Ohm, 30V Max, 0.	RT01
02	SA60	Switch,SMT,Mom.,1PSTNO	S01
02	TZ88	Transformer,SMT,50 ohms,0.03 to 125MHz	T01, T02, T03, T04
02	UDAS01	IC,SMT,Trans Array, 7 Darl., SOIC-16	U15, U20
02	UDLS03	IC,SMT,CMOS,Hex Schm,Trig,Inv, SOIC-14	U10, U12, U17, U21
02	UDLS04	IC,SMT,CMOS,8-Bit Shft Reg,Parl/P, SOIC-16	U24
02	UDLS05	IC,SMT,CMOS,8-Bit Shft Reg,Par O/P, SOIC-16	U13, U19
02	UDLS06	IC,SMT,CMOS,Quad Tri-State Buf fer, SOIC-14	U25
02	UDOS01	IC,SMT,Dual Optocoupler,SOIC-8	U14, U18, U22, U23, U26, U27, U28, U29, U32, U33, U35
02	UDTS07	IC, SMT, Full Duplex RS485 RxTx, SOIC-8	U03, U09, U30, U31
02	ULAS02	IC,SMT,Opamp,Quad,Rail-To-Rail ,SOIC-14	U11, U16
02	UT100	Oscillator, SMT, 25MHz, 50ppm, 3.3V	Y02
02	UT110	IC, Voltage Regulator, 1.5A, ADJ, Low Drop	U01
02	UW228	IC, SMT, SPI Flash, 16Mbit, 133MHz, 8-SOIC	U02
02	UW80	IC,SMT,SRC,Async,2-ch,TQFP-48	U04, U08

StockCode: NAX271B

Page 5 of 5

Description: Transfer Control Assy, (VS-TC),





<u>Component Lvl.</u>	<u>StockCode</u>	<u>Description</u>	<u>Reference Designation</u>
02	UW90	IC,SMT,Quad 2 TO 1 DATA Sel/ Mux 3 States Output,3	U07
02	UX125	IC, SMT, Wide Inout Buck Converter, SOIC8	U34, U36
02	UX161	IC, SMT, Micro, 128K, 8K SRAM, 3.3V, TQFP-100	U05
02	UX83	IC,SMT,2.5V Reference,0.1%,SOT -23-6	U06
02	XFFS03	Crystal,SMT,Fund,Par Res, 3.6864MHz,Comm	Y01
<hr/>			
01	NAPX49	Button/LED PWB, VS-TC	A02
02	CCFS52	Cap, SMT, Ceramic, 0.1uF, 10%, 25V X7R, 0603	C01, C02, C04
02	CX33	Cap,SMT,Ceramic,4.7uF,20%,10V, X5R,1206	C03
02	JA97	Conn, USB, Vertical PCB Mount, Type B	J01
02	JQ53	Conn, Header, Ribbon Cbl, 40- Pin	J02
02	QM16	Diode, LED, Bicolor, Red & Green	DS01, DS02, DS03, DS04, DS05, DS06, DS07, DS08, DS09, DS10, DS11, DS12, DS13, DS14, DS15, DS16
02	RFFS28	Resistor, SMT, MF, 150ohms, 1%, 1/10W, 0603	R01, R02, R03, R04, R05, R06, R07, R08, R09, R10, R11, R12, R13, R14, R15, R16, R17
02	RFFS46	Resistor, SMT, MF, 4750ohms, 1%, 1/10W, 0603	R19
02	RFFS50	Resistor,SMT,MF,10.0Kohms,1%,1/10W,0603	R18
02	SA69	Switch, MOM, SPDT, PB, Black, LED-Green	S07
02	SA70	Switch, MOM, SPDT, PB, Black, No LED	S01, S02, S03, S04, S05, S06
02	SA71	Switch, MOM, SPDT, PB, RED No LED	S08
02	UX118	IC, SMT, USB to RS232, 28-SSOP	U01
END OF ITEM			

SECTION 7: ELECTRICAL SCHEMATICS

This section contains electrical schematics and logic diagrams for the transmitter. Block diagrams, simplified electrical schematics, and logic diagrams may be included. Refer to [Table 7.1 on page 7.2](#) for an itemized listing.

Component Values

Unless otherwise specified on the logic or schematic diagram, the following defaults apply:

-  5 Capacitor values are shown in microfarads (uF) (e.g. 5 uF)
-  10 Resistor values are shown in ohms (e.g. 10 ohms; K = 1,000 and M = 1,000,000)
Resistor power ratings are not shown when less than 0.5 W
-  Unidentified diodes are part number BAS21HT1 (Nautel Part # QDRS01)
-  24V Unidentified transient suppressors are part number 0603E SDA-TR1 (Nautel Part # QR70)

Graphic and Logic Symbols

The graphic symbols used on electrical schematics are in accordance with IPC-2612-2010 - Sectional Requirements for Electronic Diagramming Documentation (Schematic and Logic Descriptions).

The logic symbols used on electrical schematics and logic diagrams are in accordance with IPC-2612-2010.

Reference Designations

Referenced designations were assigned in accordance with IPC-2612-2010.

Each electrical symbol is identified with its basic reference designation. To obtain the full reference designation for a specific part, prefix this basic identifier with the reference designation assigned to all higher assemblies. For example, the complete designation for a resistor (R1) on a printed wiring board (A1), that is part of a larger board (A2), would be A2A1R1.

Unique Symbols

Nautel uses unique symbols on electrical schematics to describe logic (two-state) signals. These signals differ from single-state signals or analog signals that may have multiple values.

Type of Inputs and Outputs

On electrical schematics, names used to describe logic (two-state) input and output signals are prefixed with a # symbol.

Logic Level Convention

The # prefix identifies an input or output signal that has two distinct states: high and low.

The suffix on an input or output signal name identifies the active (true) state of the signal. The high suffix (+) indicates the more positive of the two levels used to represent the logic states. The low suffix (-) indicates the less positive of the two levels.

Two types of logic, positive and negative, may be represented on a particular schematic. In positive logic, high represents the active (true) state, and low represents the inactive (false) state. In negative logic, low represents the active (true) state, and high represents the inactive (false) state.

Identifying Schematic Diagrams

Each electrical schematic in this section is identified by a number that is both the figure number and the page number. The numbers are assigned sequentially and are prefixed by the letters SD. The electrical schematics and logic diagrams included in this section are listed in [Table 7.1](#).

Table 7.1: List of Electrical Schematics

Figure #	Title
SD-1	VS150C Main-Standby Transmitter System
SD-2	VS300 Main-Standby Transmitter System
SD-3	VX150 to VX600 Main-Standby Transmitter System
SD-4	NAX271B VS-TC Transfer Controller
SD-5	NAPC166A Transfer Control PWB (Sheet 1 of 3)
SD-6	NAPC166A Transfer Control PWB (Sheet 2 of 3)
SD-7	NAPC166A Transfer Control PWB (Sheet 3 of 3)
SD-8	NAPX49 Button/LED PWB

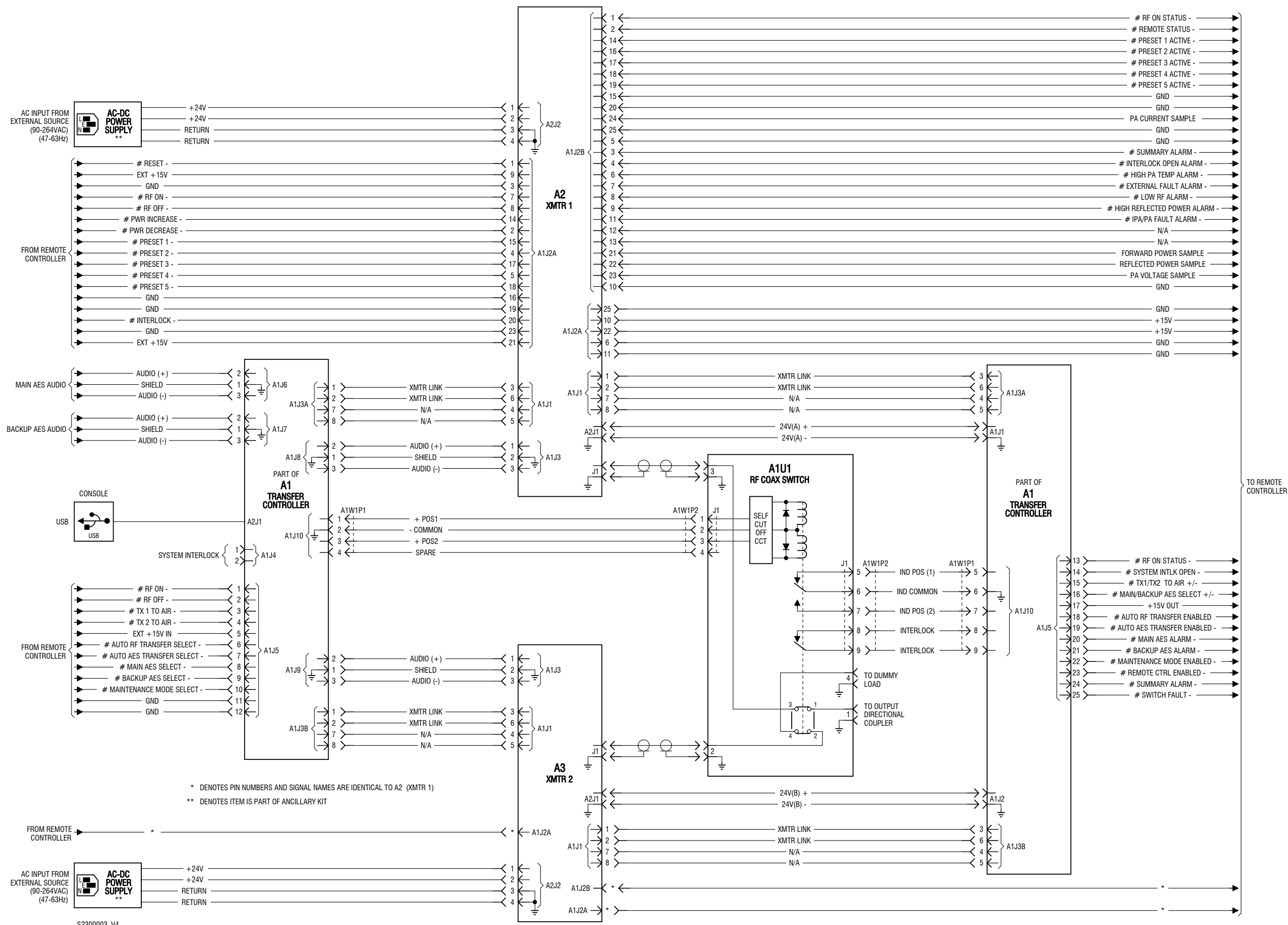
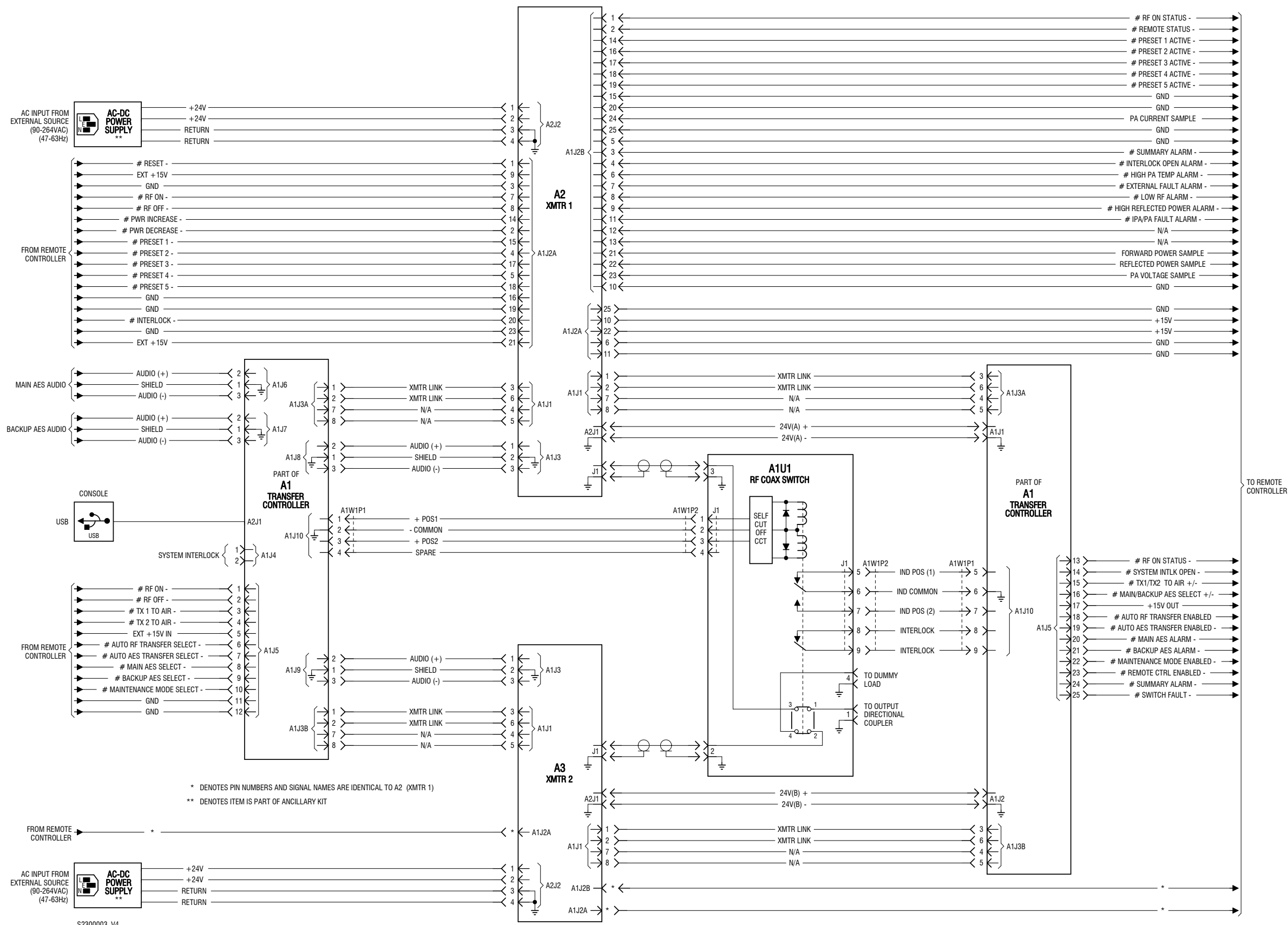
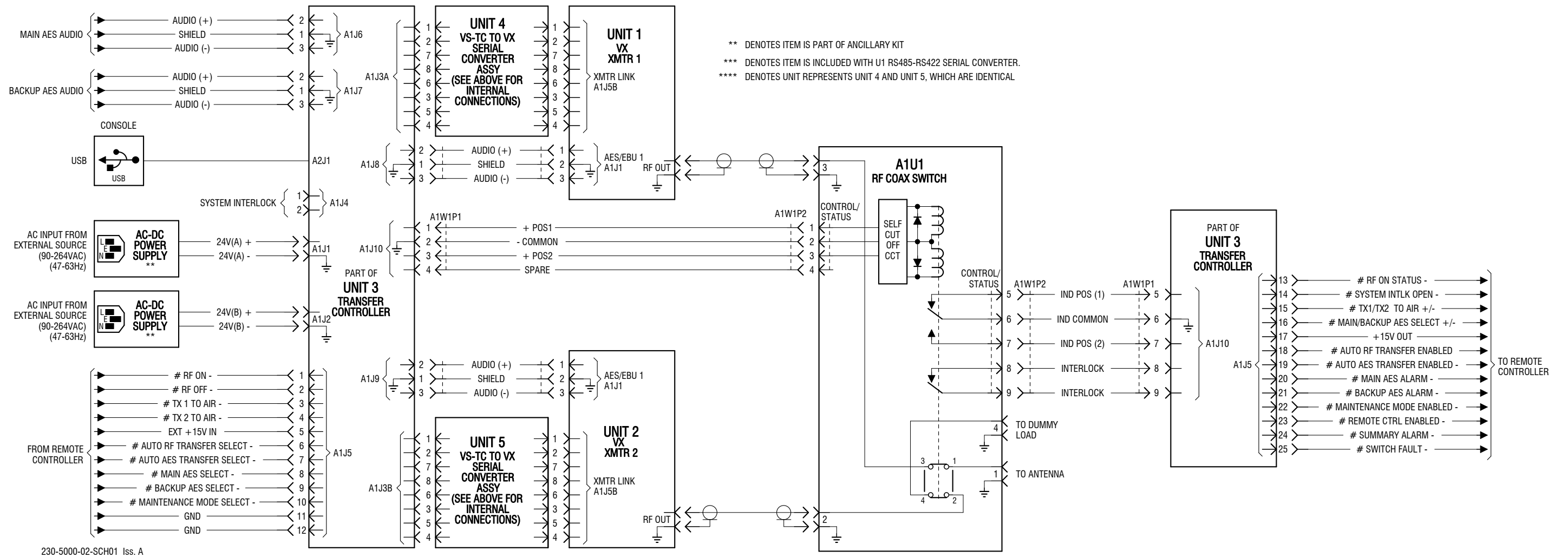
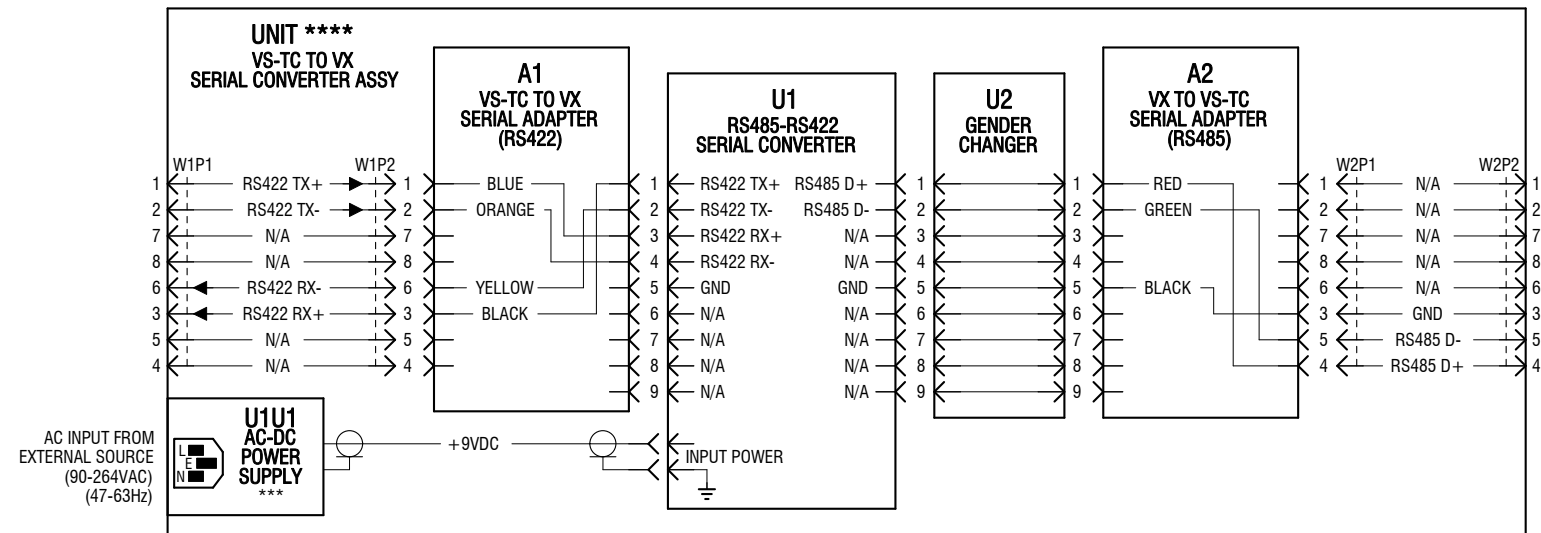

Figure SD-1: Electrical Schematic - VS150C Main-Standby Transmitter System



S2300003 V4

Figure SD-2: Electrical Schematic - VS300 Main-Standby Transmitter System



230-5000-02-SCH01 Iss. A

Figure SD-3: Electrical Schematic - VX150 to VX600 Main-Standby Transmitter System

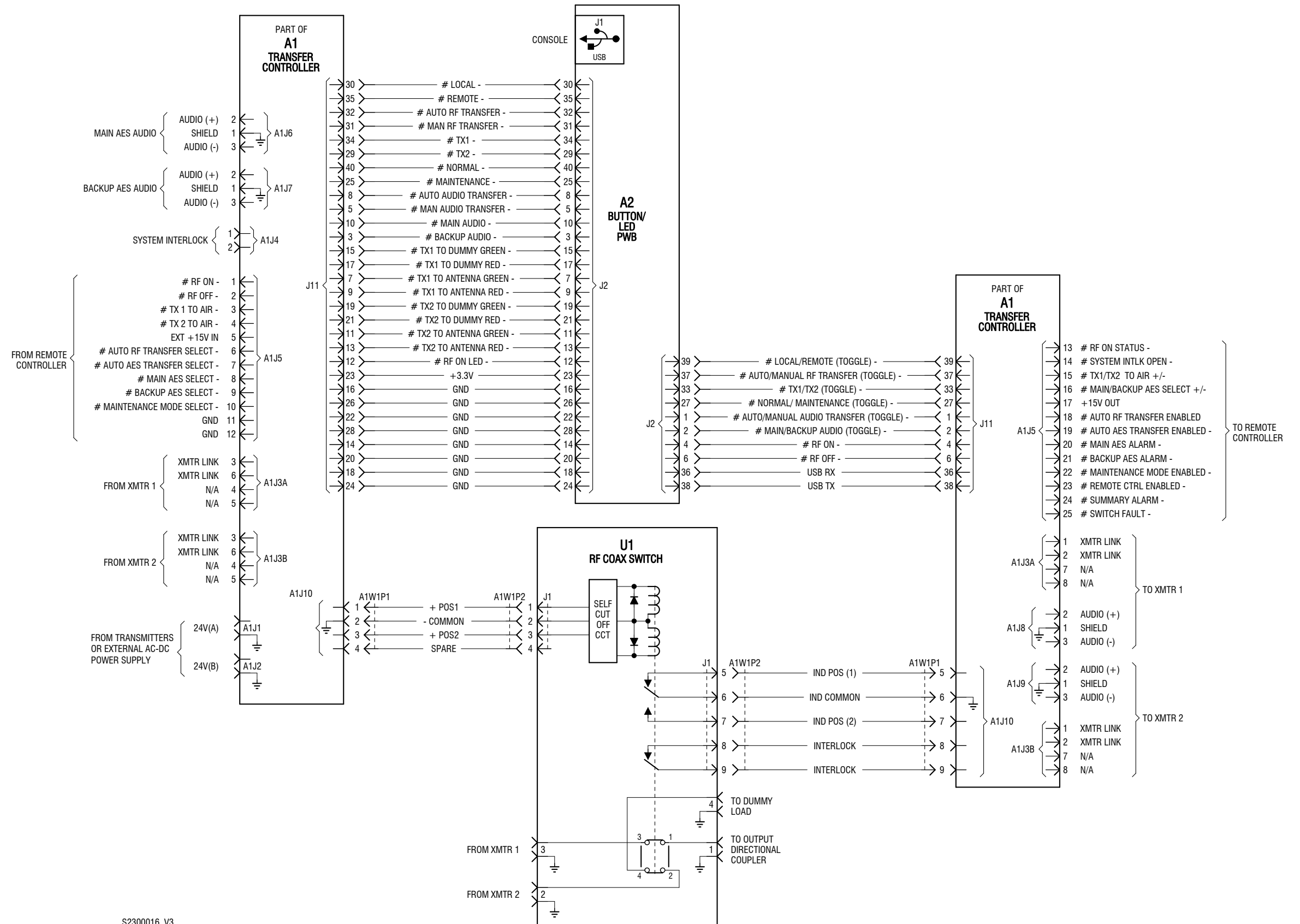

S2300016 V3

Figure SD-4: Electrical Schematic - NAX271B VS-TC Transfer Controller

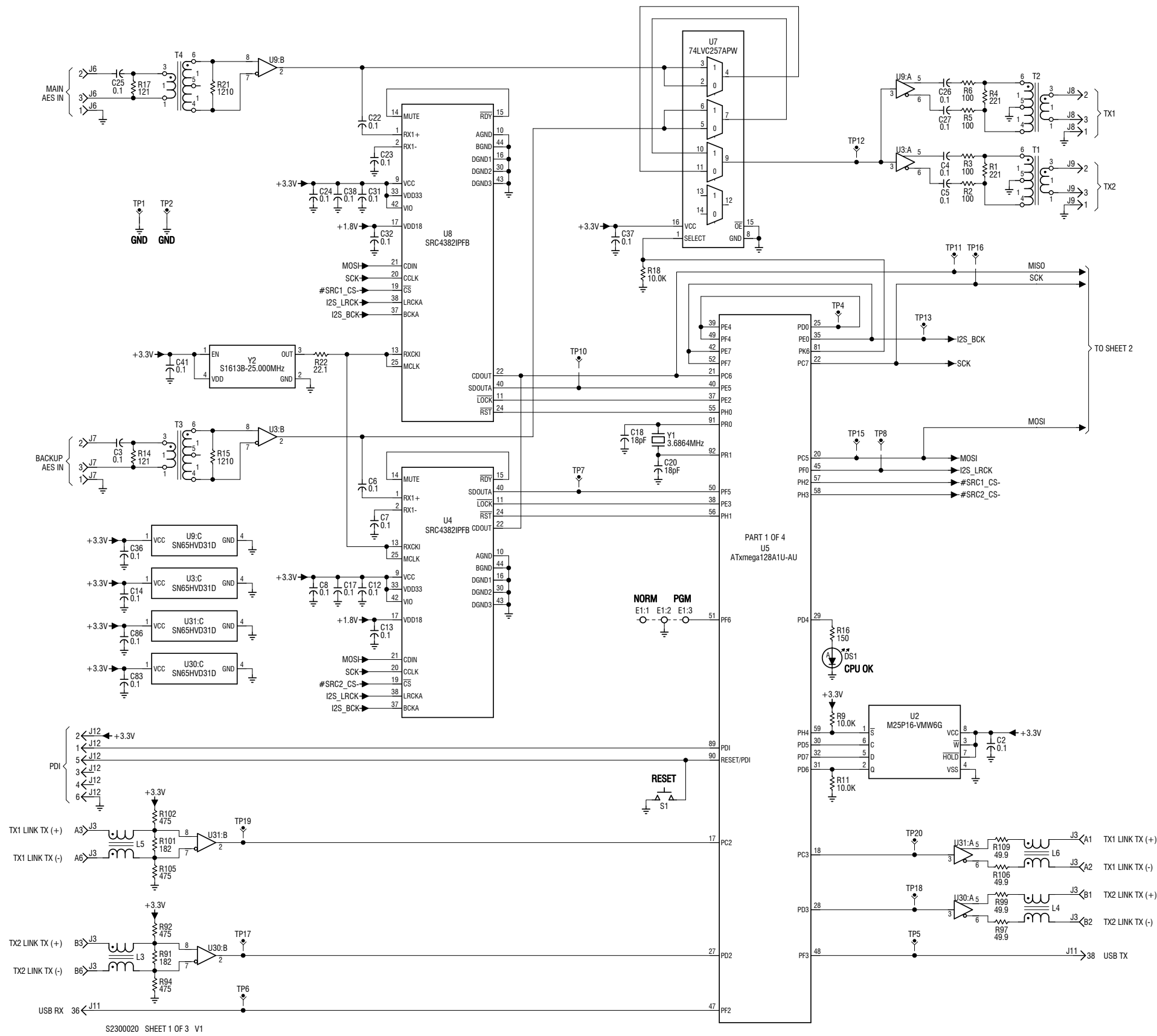

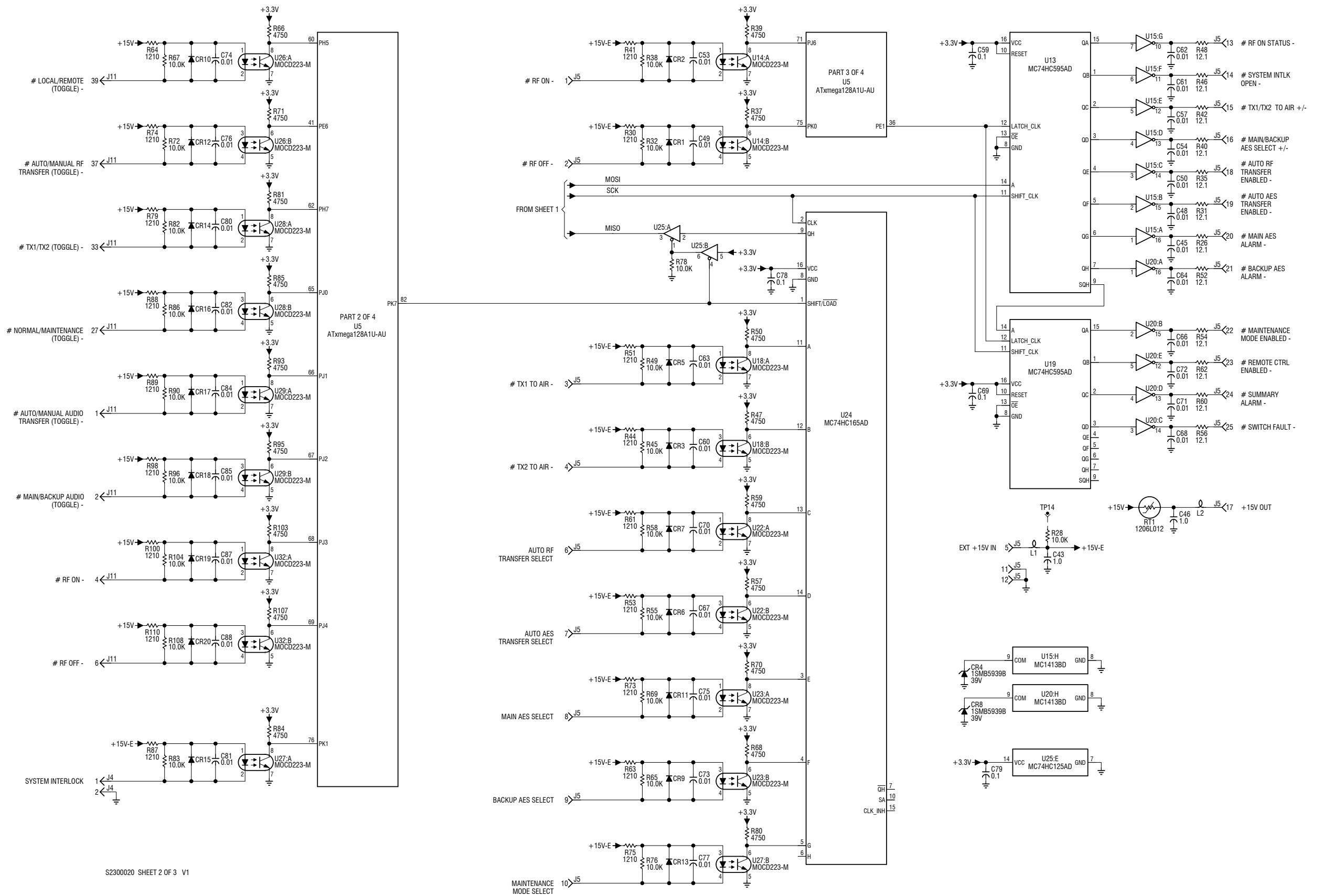
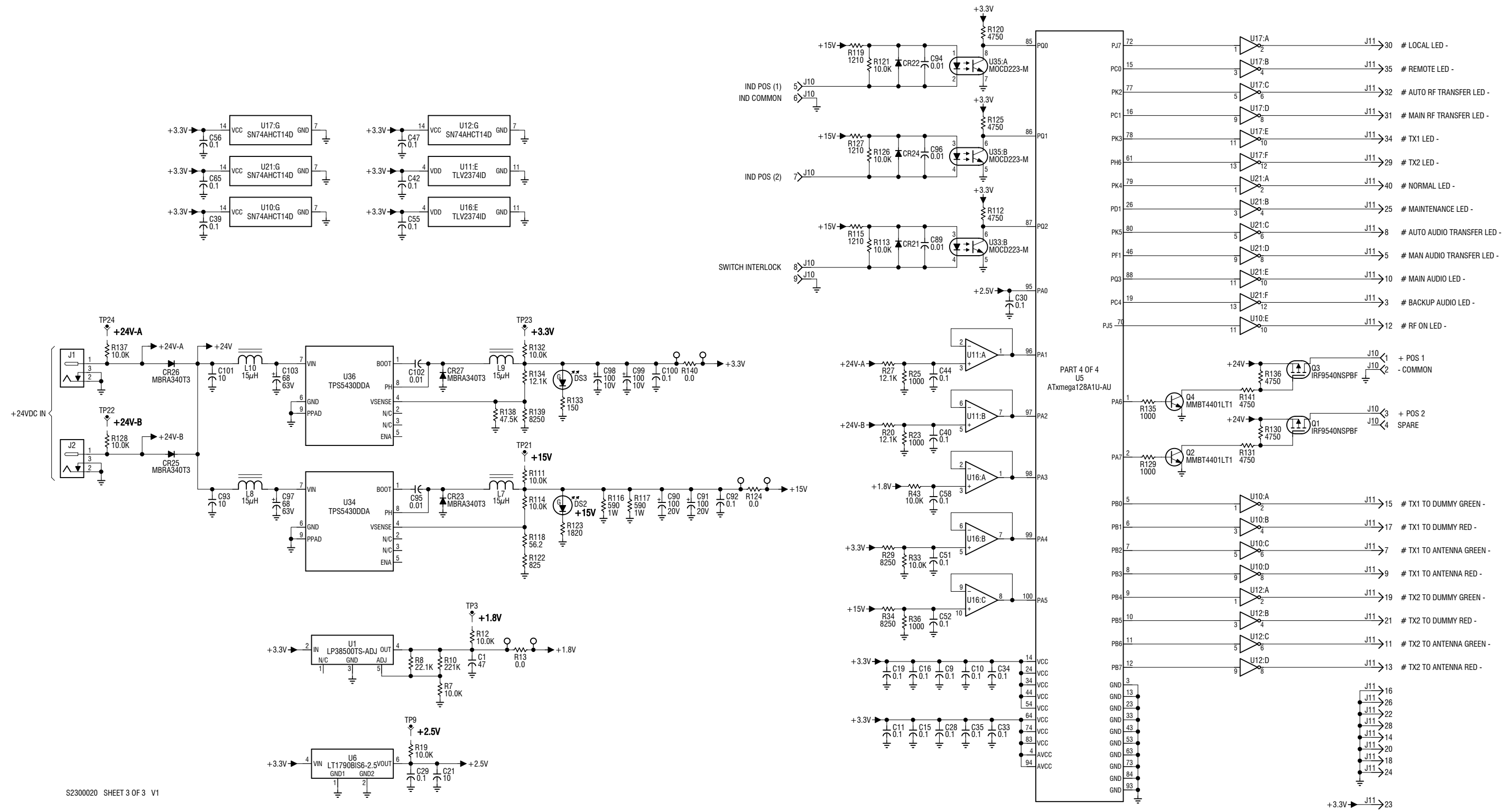
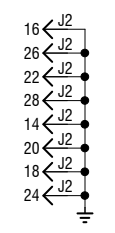
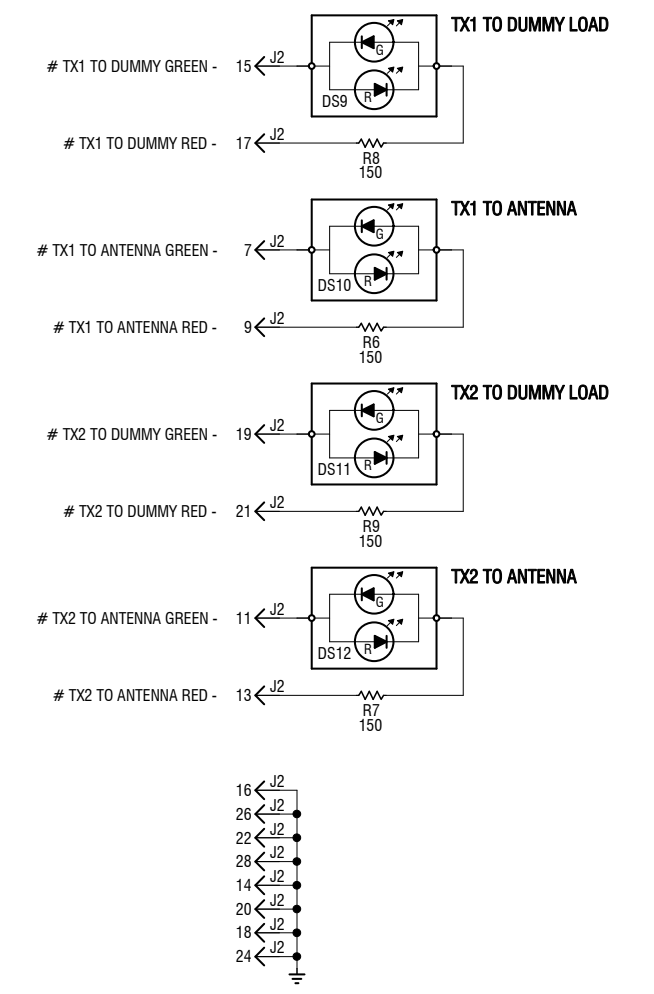
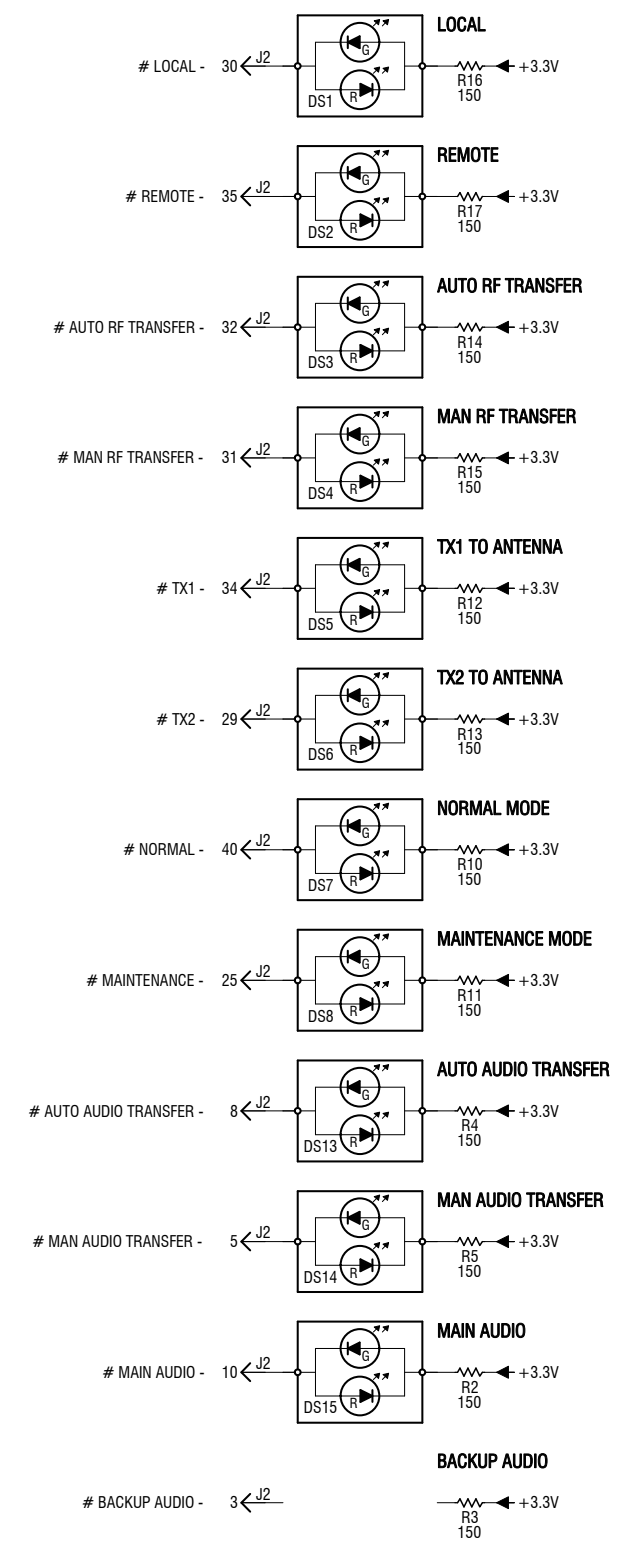
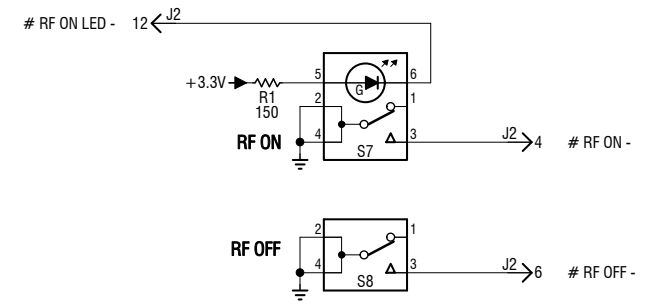
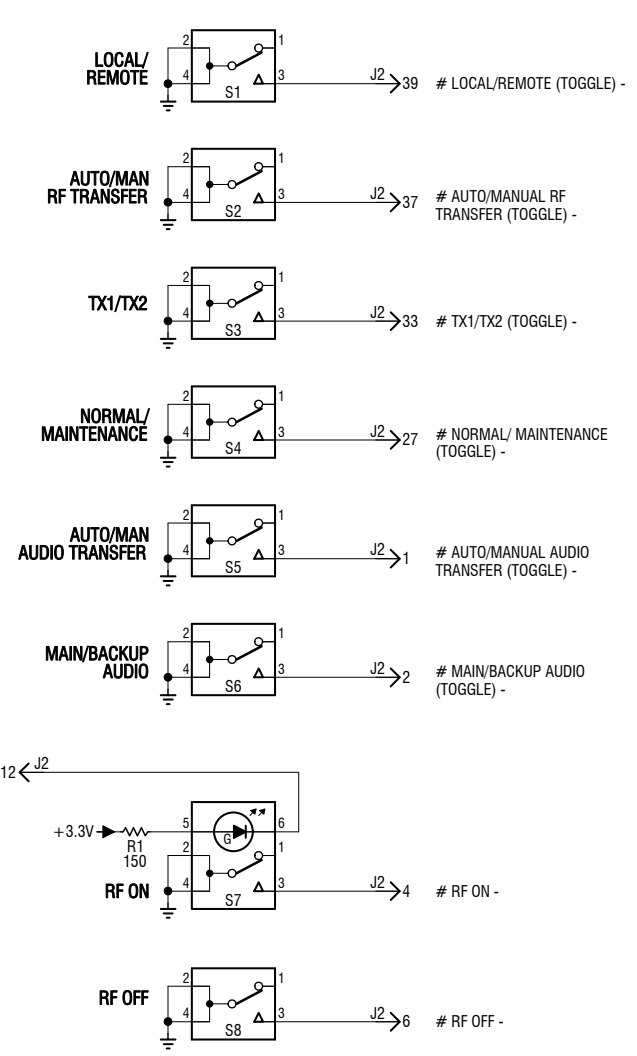
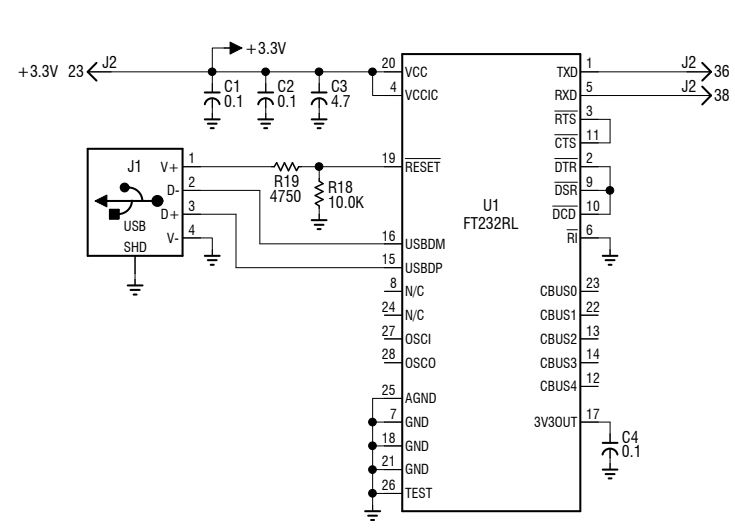

Figure SD-6: Electrical Schematic - NAPC166A Transfer Control PWB (Sheet 2 of 3)



S2300020 SHEET 3 OF 3 V1

Figure SD-7: Electrical Schematic - NAPC166A Transfer Control PWB (Sheet 3 of 3)



S2300006 V1

Figure SD-8: Electrical Schematic - NAPX49 Button/LED PWB

SECTION 8: MECHANICAL DRAWINGS

This section contains mechanical drawings for the VS-TC Transfer Controller and its assemblies. Refer to [Table 8.1 on page 8.1](#) for an itemized list.

Assembly detail drawings for assemblies and modules that have separate manuals are not included. Refer to the appropriate maintenance manual for the assembly detail of these assemblies.

Identifying Mechanical Drawings

Each mechanical drawing in this section is identified by a number that is both the figure number and the page number. The numbers are assigned sequentially and are prefixed by the letters MD. Drawings in this section are listed in [Table 8.1 on page 8.1](#).

Content of Mechanical Drawings

Mechanical drawings are illustrations that depict the location of electrical components and show assembly outline detail. Dimensional information is included, where appropriate.

When a module or assembly is the subject of its own assembly detail drawing, and it is also shown in a higher level assembly, the detail depicted in the higher level assembly may have minor differences from the module or assembly actually installed. In this case, always refer to the assembly detail drawing of the module or assembly for detailed information.

Table 8.1: List of Mechanical Drawings

Figure #	Title
MD-1	Assembly Detail - VS-TC Transfer Controller
MD-2	Assembly Detail - NAPC166A Transfer Control PWB
MD-3	Assembly Detail - NAPX49 Button/LED PWB
MD-4	Data Sheet - RF Coaxial Switch (KC96)

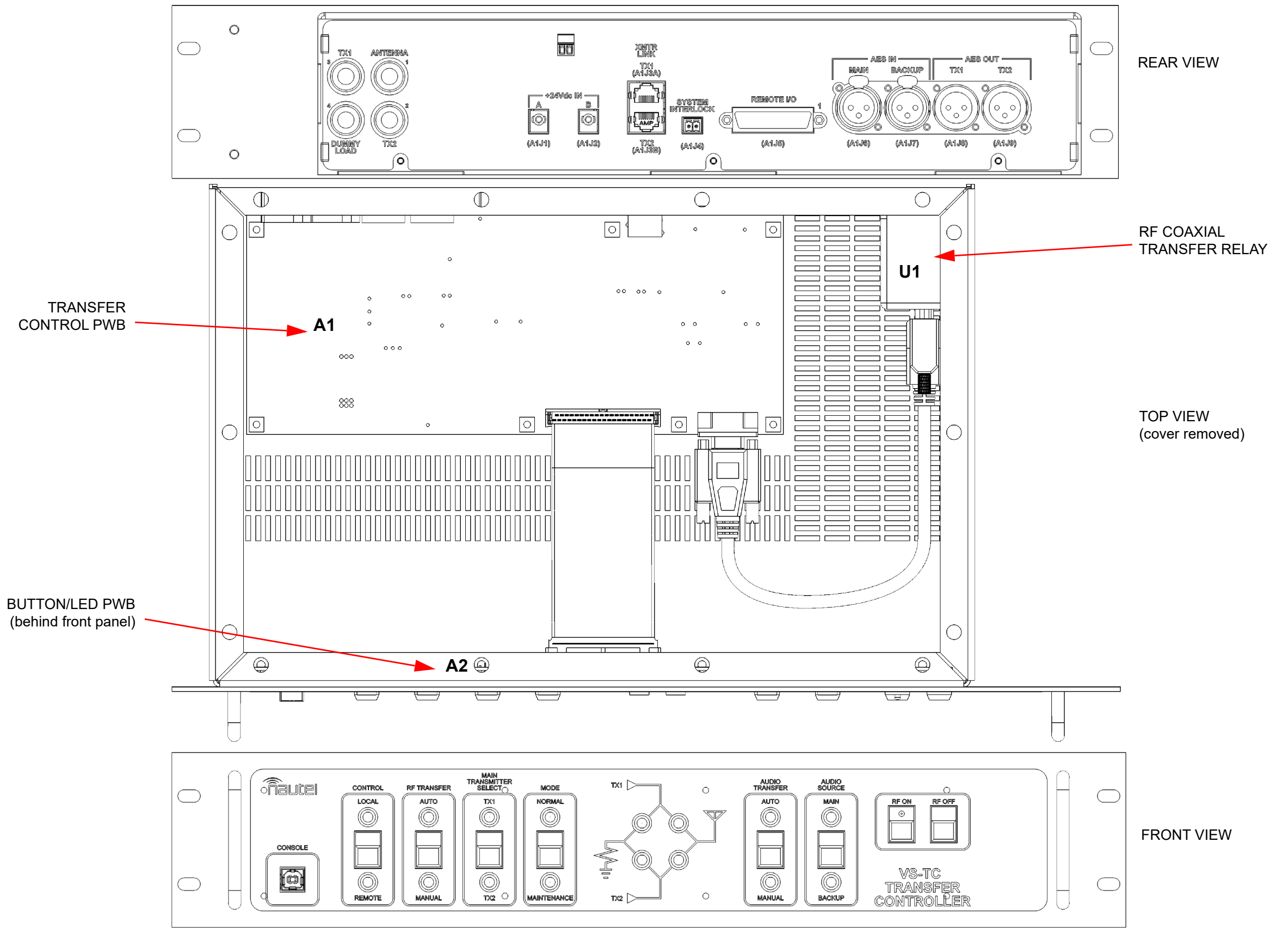

Figure MD-1: Assembly Detail - NAX271B VS-TC Transfer Controller

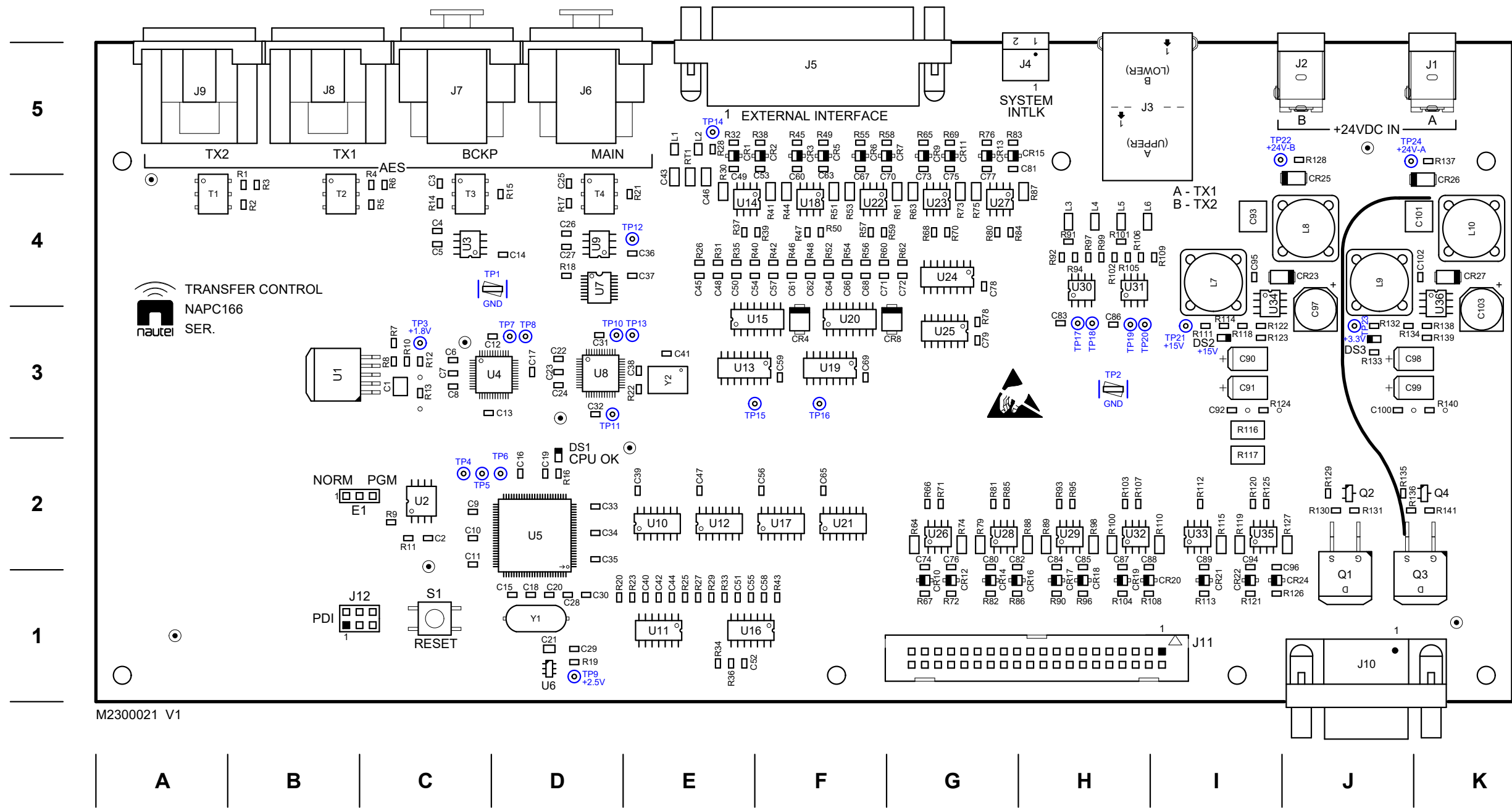

Figure MD-2: Assembly Detail - NAPC166A Transfer Control PWB

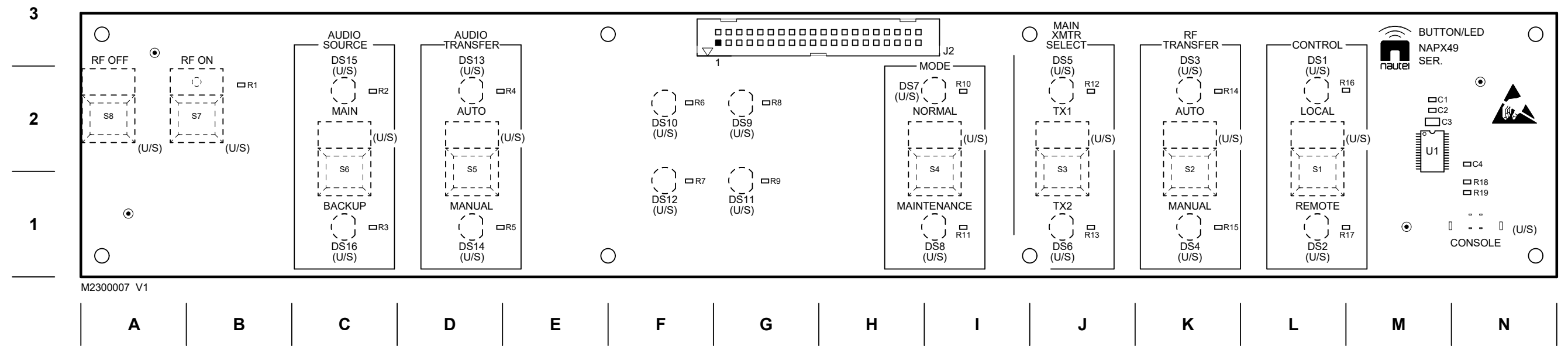
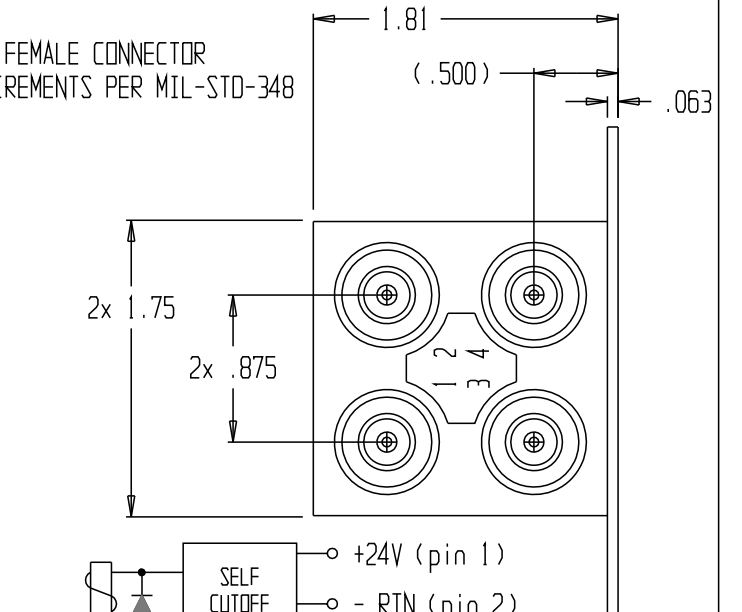
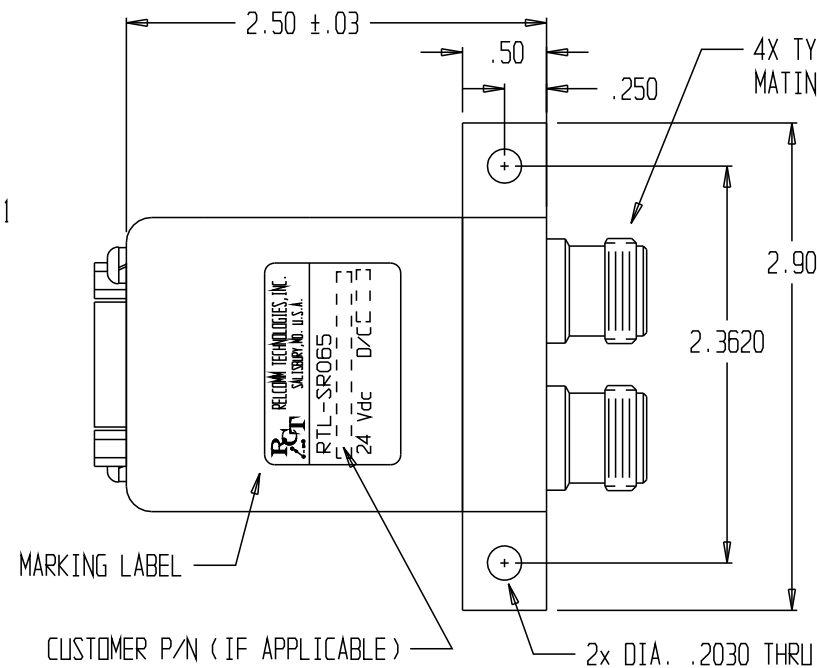
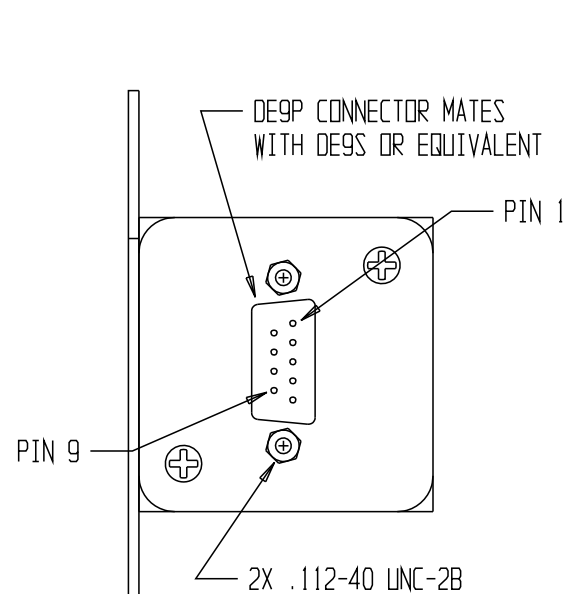

Figure MD-3: Assembly Detail - NAPX49 Button/LED PWB

NOTES:

1. INTERPRET CALLOUTS/SYMBOLS PER ASME Y14.5M-1994.
2. VERIFICATION OF CHARACTERISTICS ARE IN REFERENCE WITH MIL-DTL-3928.
3. INTERLOCK CIRCUIT PROVIDES OPEN CIRCUIT DURING SWITCHING AND 1 millisec minimum PRIOR TO RF CONTACTS OPENING FOR EITHER POSITION SELECTED.
4. POWER SPECIFIED IS RATED FOR THE FOLLOWING CONDITIONS; SEA LEVEL, 40° C, AND A LOAD VSWR OF 1.10:1 THROUGH ANY SINGLE CHANNEL. SHOULD TWO CHANNELS BE ACTIVE SIMULTANEOUSLY, COMBINED THROUGH POWER SHOULD NOT EXCEED THIS RATING. FOR CONDITIONS OTHER THAN SPECIFIED, POWER DERATING FACTORS MUST BE APPLIED. (These factors can be found on the 'Power Chart' in the RelComm catalogue or consult with factory.)



CHARACTERISTICS:

NOMINAL IMPEDANCE (OHM) -----	50		
FREQUENCY RANGE (MHz) -----	DC-108	108-250	250-1000
V.S.W.R. (MAX) -----	1.10:1	1.10:1	1.15:1
INSERTION LOSS (dB MAX) -----	0.05	0.06	0.15
ISOLATION (dB MIN) -----	85	85	85
RF POWER THRU (WATTS CW) -----	1500	1200	550 (see note 4)

TEMPERATURE RANGE (OPERATING) --	-30°C - +70°C
TEMPERATURE RANGE (STORAGE) ----	-45°C - +90°C
SWITCHING ACTION (LATCHING)-----	MAKE BEFORE BREAK
OPERATING VOLTAGE (OVER TEMP) --	20 - 28 Vdc
SWITCHING VOLTAGE (MAX @ 25°C) -	18 Vdc
ACTUATING CURRENT (mA MAX) ----	280 @ 24 Vdc & 25°C
SWITCHING TIME (MAX) -----	20 MSEC
LIFE (MINIMUM PER POSITION) ----	1*10^6 CYCLES
INDICATOR RATING -----	5 WATTS TYP., 175 Vdc MAX., .25 A MAX.
WEIGHT (OZ) -----	10.0 NDM

DE9P PIN	TERMINAL FUNCTION
1	+ POS 1
2	- COMMON
3	+ POS 2
4	SPARE
5	IND POS (1)
6	IND COMMON
7	IND POS (2)
8	INTERLOCK
9	INTERLOCK

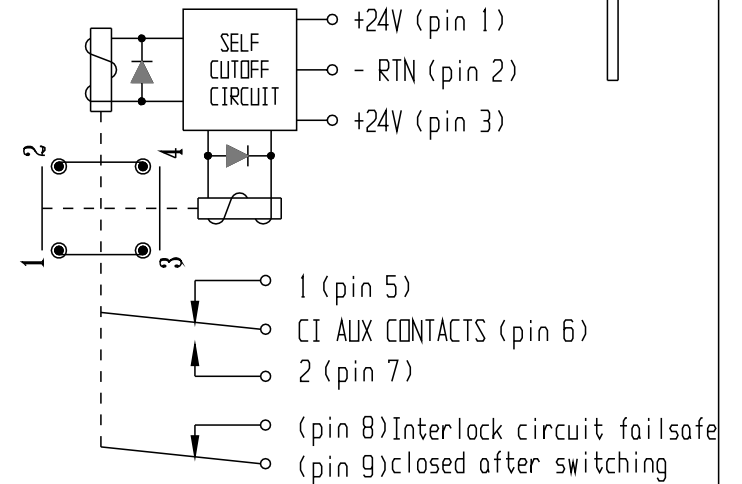

SCHEMATIC SHOWS POSITION 1 LAST ENERGIZED

POS. 1 1-2 3-4 (OPEN) 1-3 2-4 (OPEN)
 1-3 2-4 (CLOSED) POS. 2 1-2 3-4 (CLOSED)

MATERIALS/FINISH:

HOUSING -----	ALUMINUM/NICKEL
COVER -----	ALUMINUM/BLACK ANODIZED
CONNECTORS ---	BRASS/NICKEL
CONN INSUL ---	TEFLON
INT RF INSUL -	HIGH TEMP PLASTIC
CONTACTS -----	BERYLLIUM COPPER/GOLD

REV	ECN NO.	DATE	APPROVAL
E	update rf parameters	10/3/13	A. MAGDA
D	FREQ TO 1.0 GHz	8/2/13	B. JONES
C	IMPROVE ISOLATION	8/2/13	B. JONES
B	add notes + interlock	7/9/13	M. MAGDA
A	PRELIMINARY	7/8/13	M. MAGDA

UNLESS OTHERWISE SPECIFIED:
 DIMENSIONS ARE IN INCHES
 AND INCLUDE PLATING.
 TOLERANCES
 .XX ±.02 FRACTIONS ±
 .XXX ±.010 SURFACE QUALITY
 .XXXX ±.0050 63/ MAX

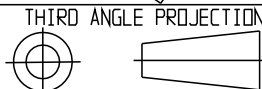

DR M. MAGDA 7/8/13
 CK B. JONES
 ENG M. MAGDA
 MFG
 QA
 THIS DRAWING AND SPECIFICATIONS ARE THE PROPERTY OF RELCOMM TECHNOLOGIES AND SHALL NOT BE REPRODUCED OR COPIED OR USED IN WHOLE OR IN PART AS THE BASIS FOR THE MANUFACTURE OR SALE OF ITEMS WITHOUT WRITTEN PERMISSION.



RELCOMM TECHNOLOGIES, INC.
 610 BEAM STREET
 SALISBURY, MARYLAND 21801

TITLE	COAXIAL TRANSFER RELAY 24 Vdc "LATCHING" W/IND & SELF CUTOFF		
SIZE	B	DWG NO.	RTL-SR065
SCALE	1:1	DO NOT SCALE DWG	SHEET 1 OF 1

Figure MD-4: Data Sheet - RF Coaxial Switch (KC96)