

---

## SECTION 4.1: RESPONDING TO ALARMS

This section provides instructions you need when performing troubleshooting on the NX10 transmitter, including the following topics:

- [Corrective Maintenance](#)
- [Electrostatic Protection - see page 4.1.3](#)
- [Identifying an Alarm - see page 4.1.4](#)
- [Troubleshooting an Alarm - see page 4.1.6](#)
- [Accessing the Inside of the Transmitter - see page 4.1.44](#)
- [Troubleshooting Tips - see page 4.1.46](#)
- [Troubleshooting RF Power Modules - see page 4.1.57](#)
- [Other Module Replacement Procedures - see page 4.1.43](#)

If none of the procedures and alarms described in this section address your problem, contact Nautel for assistance.

### Corrective Maintenance

Corrective maintenance procedures consist of identifying and correcting defects or deficiencies that arise during transmitter operation. Local and/or remote alarm signals are generated when a malfunction occurs. If an alarm condition is caused by a malfunction in the RF power stage, the transmitter may maintain operation at a reduced RF output level. The nature of the fault – and station policy – will dictate whether an immediate maintenance response is necessary. Fault analysis and rectification may be conducted from three different levels, with a different technical competence level required for each: on-air troubleshooting, remote or local, and off-air troubleshooting.

**CAUTION!** The transmitter contains many solid state devices that may be damaged if subjected to excessive heat or high voltage transients. Take every effort to ensure that circuits are not overdriven or disconnected from their loads while turned on.

### On-Air Troubleshooting

On-air troubleshooting can be performed from a remote location, or locally at the transmitter site.

---

## Remote Troubleshooting

Remote on-air troubleshooting consists of monitoring the transmitter's radiated signal using an on-air monitor or via a LAN connection, and observing the status of each remote fault alarm indicator. Information obtained from these sources should enable an operator to decide whether an alarm response may be deferred to a more convenient time, an immediate corrective action must be taken, or if a standby transmitter must be enabled (if one is available). It is recommended that the significance of remote indications, and the appropriate responses, be incorporated into a station's standard operating procedures. Refer to ["Identifying an Alarm" on page 4.1.4](#) to determine the remedial action required for a given fault.

## Local Troubleshooting

Local on-air troubleshooting consists of monitoring the transmitter's integral meters and fault alarm indicators. Analysis of this data will normally identify the type of fault, and in most cases will determine what corrective action must be taken. Refer to ["Identifying an Alarm" on page 4.1.4](#) to determine the remedial action required for a given fault.

The power amplifier stage contains an integral modular reserve (IMR) feature. This feature permits the transmitter to operate at a reduced RF output level when a malfunction occurs in one of its power modules. Station operating procedures will dictate whether a reduced RF output level is acceptable. When a reduced RF output level can be tolerated, replacement of the defective RF power module may be deferred to a convenient time. A defective RF power module may be removed from the transmitter for servicing, while the transmitter is operating, provided that the conditions in the removal instructions detailed in ["Removing an RF Power Module" on page 4.1.52](#) are met.

**WARNING! FAILURE TO FOLLOW THE RF POWER MODULE REMOVAL INSTRUCTIONS MAY RESULT IN INJURY TO THE OPERATOR AND SERIOUS PHYSICAL DAMAGE TO THE RF POWER MODULE AND TRANSMITTER.**

## Off-Air Troubleshooting

Off-air troubleshooting must be performed when the replacement of a defective RF power amplifier module, or routine on-air calibration adjustments, will not restore operation.

It is recommended that the transmitter's output be connected to a precision 50  $\Omega$  resistive dummy load (rated for at least 1.5 times the rated transmitter carrier power) before starting off-air troubleshooting procedures. If an appropriate dummy load is not available, troubleshooting for a majority of faults can be performed with RF power stage turned off. The transmitter may remain connected to its antenna system for these procedures.

**NOTE:** Reduce the RF output level to a minimal value when troubleshooting faults in the power amplifier stage while the transmitter's RF output is connected to the antenna system.

---

## Electrostatic Protection

The transmitter's assemblies contain semiconductor devices that are susceptible to damage from electrostatic discharge. The following precautions must be observed when handling an assembly which contains these devices.

**CAUTION!** Electrostatic energy is produced when two insulating materials are rubbed together. A person wearing rubber-soled shoes, walking across a nylon carpet or a waxed floor, can generate an extremely large electrostatic charge. This effect is magnified during periods of low humidity. Semiconductor devices such as integrated circuits, field-effect transistors, thyristors and Schottky diodes may be damaged by this high voltage unless adequate precautions are taken.

## Electrical Discharging of Personnel

Personnel should be electrically discharged by a suitable grounding system (e.g., anti-static mats, grounding straps) when removing an assembly from the transmitter, and while handling the assembly for maintenance procedures.

## Handling/Storage

An assembly should be placed in an anti-static bag when it is not installed in a transmitter, or when it is not undergoing maintenance. Electronic components should be stored in anti-static materials.

## Tools/Test Equipment

Testing and maintenance equipment – including soldering and unsoldering tools – should be suitable for contact with static sensitive semiconductor devices.

## Stress Current Protection

Every precaution should be taken to ensure the static sensitive semiconductor devices are protected from unnecessary stress current. This is achieved by ensuring that current is not flowing when an electrical connection is broken, and that voltages are not present on external control/monitoring circuits when they are connected.

## Identifying an Alarm

You can identify an alarm locally by viewing the front panel (see “[Front Panel UI Alarm Checks](#)”) or remotely by viewing the remote AUI’s Transmitter Status page (see “[Remote AUI Alarm Checks](#)” on page 4.1.5). After successfully identifying an alarm, attempt to determine the cause of the alarm and correct it (see “[Troubleshooting an Alarm](#)” on page 4.1.6).

### Front Panel UI Alarm Checks

There two ways to check for alarms on the front panel:

- [Alarm/Status LEDs](#)
- [View Alarms Screen](#) - see page 4.1.5

#### Alarm/Status LEDs

There are four LEDs on the left-hand side of the LCD display that provide information about the operational status of various sections of the transmitter - Controller/Exciter, Power Amplifier, Output Network and Power Supply (see [Figure 4.1.1](#)). The LEDs can glow green, amber or red. Typically, green indicates normal operation, amber indicates a warning, and red indicates a fault or error.

Figure 4.1.1: Alarm/Status LEDs

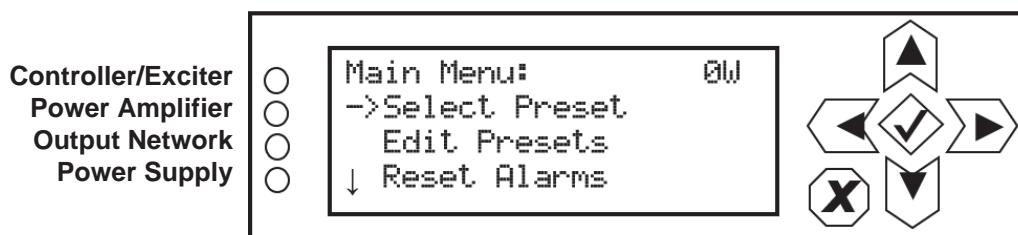

When an LED is:

- ❖ Green - transmitter is on, with no known faults that would affect the normal operation of the transmitter.
- ❖ Amber - a fault is present that affects the normal operation of the transmitter and may cause a reduction in RF power, but the transmitter is still producing RF power.
- ❖ Red - a fault is present and the transmitter is not producing RF power.

When a fault is present, the transmitter may still produce an RF output. In this case, or if the transmitter has shut down, you should schedule and commence more in-depth fault diagnosis. See “[View Alarms Screen](#)” on page 4.1.5.

### View Alarms Screen

If an alarm exists and is currently being recognized by the transmitter system, it is displayed in the View Alarms screen (Main Menu -> View Status -> View Alarms) of the front panel Display (see Figure 4.1.2). Scroll through the View Alarms screen to view the active faults.

Figure 4.1.2: View Alarms Screen

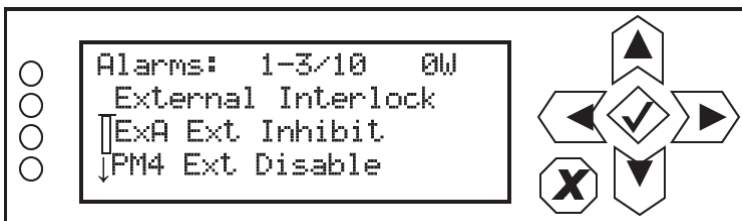

Alarm prefix indicates origin:  
 Exc: Exciter (single exciter systems)  
 ExA: Exciter A (dual exciter systems)  
 ExB: Exciter B (dual exciter systems)  
 PM#: Power Module #  
 Rk: Rack Interface  
 Exg: Engine  
 No prefix: Controller

### Remote AUI Alarm Checks

The colour of the Status button (see Figure 4.1.3 on page 4.1.5) at the bottom of the remote AUI indicates the severity of the highest offending alarm. The button can display green, amber or red. When the Status button is:

- ❖ Green - transmitter is on, with no known faults that would affect the normal operation of the transmitter.
- ❖ Amber - a fault is present that affects the normal operation of the transmitter and may cause a reduction in RF power, but the transmitter is still producing RF power.
- ❖ Red - a fault is present and the transmitter is not producing RF power.

Figure 4.1.3: Transmitter Status Page

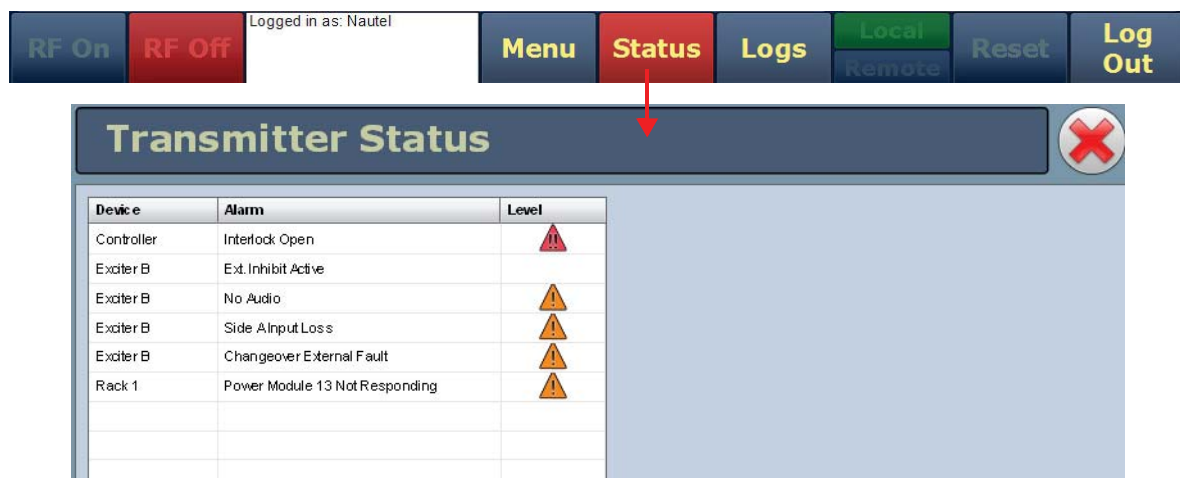

Click the Status button to view the Transmitter Status page (see [Figure 4.1.3 on page 4.1.5](#)), which displays a list of active alarms. Alarms are listed by their origin (Device column), then by name (Alarm column), and then by severity (Level column).

- The Device column displays the sub-system origin of the alarm. The sub-systems that can be displayed are:
  - ❖ Controller: All alarms in this sub-system apply to the controller.
  - ❖ Exciter A or B: All alarms in this sub-system apply to an exciter (A or B).
  - ❖ Rack #: All alarms in this sub-system apply to a rack (cabinet) (only Rack 1 for NX10).
  - ❖ Module #: All alarms in this sub-system apply to a specific RF power module (1 through 4).
  - ❖ Engine: For systems with Engine installed, all alarms in this sub-system apply to the Engine.
- The Alarm column displays the alarm name. Use this name as a cross-reference during troubleshooting (see ["Troubleshooting an Alarm" on page 4.1.6](#)).
- The Level column displays a symbol indicates the severity of the alarm, as follows:
  - ❖ One Yellow ! - low severity, normal operation of transmitter not affected
  - ❖ One Orange ! - medium severity, normal operation of transmitter affected, RF output may be reduced
  - ❖ Two Red !! - high severity, RF output is inhibited

## Troubleshooting an Alarm

Troubleshoot an alarm as follows:

**NOTE:** Before undertaking any troubleshooting, record all meter readings and note if any other alarms are displayed on the front panel UI's View Alarms page or the remote AUI's Transmitter Status page. Record all alarms.

1. Attempt to clear any latching alarms:
  - ❖ locally, using the front panel UI, by pressing the checkmark button in the Main Menu -> View Status -> Reset Alarms screen.
  - ❖ remotely, using the remote AUI, by pressing the Reset button on the bottom banner of the AUI page.

If the alarm persists, it will not clear from the display.

- 
2. Locate the alarm name in the appropriate table (see below) to determine the cause of the alarm and perform any recommended procedures in the Description and Troubleshooting Action column. This may also lead to replacing a suspect PWB, power supply or fan, as detailed in [Table on page 4.1.37](#).

- ❖ See [Table 4.1.1 on page 4.1.8](#) for Controller alarms
- ❖ See [Table 4.1.2 on page 4.1.19](#) for Exciter A/B alarms
- ❖ See [Table 4.1.3 on page 4.1.28](#) for Engine alarms
- ❖ See [Table 4.1.4 on page 4.1.29](#) for RF Power Module alarms
- ❖ See [Table 4.1.5 on page 4.1.34](#) for Rack alarms

**NOTE:** [Table 4.1.1](#) through [Table 4.1.5](#) list all **Alarms** that can occur, sorted alphanumerically for each sub-system (e.g., Controller, Exciter A/B, Module, etc.), including both the names displayed on the AUI and, if different, the front panel UI (in parentheses). The **Severity** column shows the low, medium or high severity of the alarm (see [page 4.1.6](#)). The **Description and Troubleshooting Action** column provides a brief description of the alarm, troubleshooting tips and a cross-reference to more detailed troubleshooting, as applicable.

- ❖ See [Table 4.1.6 on page 4.1.38](#) for Summary alarms

**NOTE:** [Table 4.1.6](#) lists the Summary alarms that can be configured for remote monitoring through the front panel UI or remote AUI's Remote I/O -> Remote Outputs menu (see the "Operating the Transmitter" section of the Operations & Maintenance Manual for configuration details). Each Summary alarm can be triggered by any one alarm in a specific sub-set, as shown in [Table 4.1.6](#). The **Description and Trigger Alarms** column of [Table 4.1.6](#) provides a brief description of the summary alarm and a list of the triggering alarms. To determine the root cause(s) of a Summary Alarm, check the front panel UI or remote AUI for an offending trigger alarm and refer to its troubleshooting information for more details.

3. If troubleshooting and subsequent replacement of a suspect PWB or module causes the alarm to disappear, the alarm has been successfully cleared. If the fault condition does not clear contact Nautel Customer Service for assistance.

Table 4.1.1: Troubleshooting Controller Alarms

Controller Alarm Name (AUI/UI)	Severity	Description and Troubleshooting Action
+1.2V Fail	Low	This alarm occurs if the +1.2 V rail is outside its acceptable range of 1.08 V to 1.32 V. The transmitter takes no action on this alarm. Replace the control/interface PWB (see <a href="#">"Control/Interface PWB Removal/Replacement"</a> on page 4.1.65).
+3.3V Fail	Low	This alarm occurs if the +3.3 V rail is outside its acceptable range of 2.97 V to 3.63 V. The transmitter takes no action on this alarm. Replace the control/interface PWB( see <a href="#">"Control/Interface PWB Removal/Replacement"</a> on page 4.1.65).
-15V Fail	Low	This alarm occurs if the -15 V rail is outside its acceptable range of -16.5 V to -13.5 V. The transmitter takes no action on this alarm. Replace the control/interface PWB (see <a href="#">"Control/Interface PWB Removal/Replacement"</a> on page 4.1.65).
Arc Shutback	High	This alarm indicates the transmitter has entered a shutback (see Shutback on page 3.1.10 of the Operations & Maintenance Manual for a description of the shutback routine) due to one of the rack controller’s arc detectors being activated. When this fault occurs, the transmitter immediately inhibits PDM and the transmitter's output power drops to 0 W. Once the fault clears the transmitter will automatically recover, either to the power setpoint, or to a reduced power as determined by the cutback routine (see Cutback on page 3.1.11 of the Operations & Maintenance Manual for a description of the cutback routine). Visually inspect the inside of the transmitter to locate the fault causing the arc detector to trigger.
Audio Loss Shutdown	High	This alarm occurs if the modulation level is below the preset threshold for the designated period of time set in the Audio Loss settings of the current preset, and the desired action was set to RF Inhibit. This will cause the transmitter to shut down its RF output until the exciter determines that the modulation source has returned. If this alarm is unexpected, check the audio inputs specified in the preset and verify there is signal present.
Brownout Reset	Medium	This alarm is only visible in the transmitter logs, and indicates the controller was reset because its +5 V power supply voltage was less than +4.3 V, but remained above +1.4 V, and then subsequently recovered. This alarm should occur concurrently with other alarms. Follow the troubleshooting information for the associated alarms. If the alarm persists without the presence of other alarms, replace the control/interface PWB (see <a href="#">"Control/Interface PWB Removal/Replacement"</a> on page 4.1.65).



Table 4.1.1: Troubleshooting Controller Alarms

Controller Alarm Name (AUI/UI)	Severity	Description and Troubleshooting Action
Combiner Interlock Open (Combiner Interlock)	High	This alarm will only occur if the transmitter is connected in a combined system. The alarm indicates that the interlock signal from the combiner is open. When this alarm occurs, the transmitter immediately inhibits the PDM and the transmitter's output power drops to 0 W. If this condition persists for more than 10 seconds, the transmitter will inhibit the RF power modules, fans and B+ power supply. The transmitter will automatically recover when the condition is cleared. Check the combiner for a condition that may cause it to open the interlock to the transmitter. If so, troubleshoot the cause of that condition. If not, inspect the wiring between the combiner and the transmitter and verify there is no damage. If the alarm persists, replace the control/interface PWB (see <a href="#">"Control/Interface PWB Removal/Replacement"</a> on page 4.1.65).
Controller Reset	Medium	This alarm is only visible in the transmitter logs, and indicates the controller was reset because its +5 V power supply voltage was less than 1.4 V, which normally happens due to a loss of ac power. If the controller is rebooting without losing ac power to the transmitter, check for the presence of other alarms at the time of the controller reset and follow the troubleshooting information for those alarms. Otherwise, replace the control/interface PWB (see <a href="#">"Control/Interface PWB Removal/Replacement"</a> on page 4.1.65).

Table 4.1.1: Troubleshooting Controller Alarms

Controller Alarm Name (AUI/UI)	Severity	Description and Troubleshooting Action
EEPROM Failure: Config (EEP Fail Config)	Medium	<p>This alarm occurs when the transmitter is unable to read the following settings from EEPROM upon boot-up. The transmitter will revert to its initial default settings, which may be different from the values set before the transmitter was shipped. The alarm will remain asserted until at least one of the settings are changed. Affected settings are:</p> <ul style="list-style-type: none"> <li>– Main Exciter (Defaults to A)</li> <li>– Standby Exciter Installed (Defaults to Yes)</li> <li>– Exciter Sync (Defaults to None)</li> <li>– Active Max Power Lockout (Defaults to 1)</li> <li>– RF Monitor Select (Defaults to forward power)</li> <li>– Host Watchdog Enable (Defaults to OFF, should be turned ON)</li> <li>– UI Backlight Brightness (Defaults to 100%)</li> <li>– UI Inactivity Timeout (Defaults to 10 minutes)</li> <li>– Network Configuration</li> </ul> <p>Configure the affected settings as desired. Cycle (turn off, then on) ac power to the transmitter. If the alarm persists, replace the battery on the control/interface PWB and retry the above steps. If the alarm persists, replace the control/interface PWB (see <a href="#">“Control/Interface PWB Removal/Replacement”</a> on page 4.1.65)..</p>
EEPROM Failure: Potentiometers (EEP Fail Pots)	Medium	<p>This alarm occurs when the transmitter is unable to read its RF Symmetry Adjustment calibration from EEPROM upon boot-up. The alarm will remain asserted until the RF Symmetry has been re-calibrated. When this alarm occurs, the transmitter will load a default level of exactly mid-scale for the symmetry adjustment potentiometers. Set the RF Symmetry Adjust per the factory configuration. Cycle (turn off, then on) ac power to the transmitter. If the alarm persists, replace the battery on the control/interface PWB and retry the above steps. If the alarm persists, replace the control/interface PWB (see <a href="#">“Control/Interface PWB Removal/Replacement”</a> on page 4.1.65).</p>

Table 4.1.1: Troubleshooting Controller Alarms

Controller Alarm Name (AUI/UI)	Severity	Description and Troubleshooting Action
EEPROM Failure: Remotes (EEP Fail Remotes)	Medium	This alarm occurs when the transmitter is unable to read its remote I/O configuration from EEPROM upon boot-up. The transmitter will revert to the initial default remote I/O settings and the alarm will remain asserted until a new remote input/output is configured. Reconfigure the remote I/O settings as desired. Cycle (turn off, then on) ac power to the transmitter. If the alarm persists, replace the battery on the control/interface PWB and retry the above steps. If the alarm persists, replace the control/interface PWB (see <a href="#">"Control/Interface PWB Removal/Replacement"</a> on page 4.1.65).
EEPROM Failure: Schedule (EEP Fail Schedule)	Medium	This alarm occurs when the transmitter is unable to read its schedule configuration from EEPROM upon boot-up. The transmitter will establish a new, completely blank schedule. The alarm will remain asserted until at least one new scheduled event is created. Recreate the desired schedule settings. Cycle (turn off, then on) ac power to the transmitter. If the alarm persists, replace the battery on the control/interface PWB and retry the above steps. If it still persists, replace the control/interface PWB (see <a href="#">"Control/Interface PWB Removal/Replacement"</a> on page 4.1.65).
EEPROM Failure: Thresholds (EEP Fail Thresholds)	Medium	This alarm occurs when the transmitter is unable to read the setting for the Fast SWR Shutback threshold voltage from EEPROM upon boot-up. The transmitter will revert to its initial default settings, which may be different from the values set before the transmitter was shipped. The alarm will remain asserted until the setting is changed. Contact Nautel to obtain to correct value for the Fast SWR Shutback Voltage threshold and configure the setting accordingly. Cycle (turn off, then on) ac power to the transmitter. If the alarm persists, replace the battery on the control/ interface PWB and retry the above steps. If the alarm persists, replace the control/interface PWB (see <a href="#">"Control/Interface PWB Removal/ Replacement"</a> on page 4.1.65).

Table 4.1.1: Troubleshooting Controller Alarms

Controller Alarm Name (AUI/UI)	Severity	Description and Troubleshooting Action
Exciter A or B Not Responding (Exciter A or B Offline)	Medium	This alarm occurs when the controller is configured to expect exciter A (or B) is installed, and it has failed to receive any serial response from that exciter. The alarm is cleared if the controller is configured to expect that same exciter is not installed, or if it receives a serial response from the exciter. When this alarm occurs on the standby exciter, automatic changeover will be inhibited. When this alarm occurs on the main exciter, if automatic changeovers are enabled and the main exciter is active and the standby exciter is responding to serial communication, an automatic changeover will occur. If there are two exciters in the transmitter, swap exciter positions. If the alarm follows the exciter, or there is only one exciter in the system, replace the digital AM exciter PWB (see <a href="#">"Digital AM Exciter PWB Replacement"</a> on page 4.1.69). If the alarm persists, or the alarm remains with the position, replace the control/interface PWB (see <a href="#">"Control/Interface PWB Removal/Replacement"</a> on page 4.1.65).
Exciter Changeover (Auto Changeover)	Medium	This alarm indicates that an automatic exciter changeover has occurred. This alarm will occur as a result of another alarm triggering the automatic exciter changeover. Follow the troubleshooting information for the associated alarm.
Exgine Not Responding (Exgine Offline)	Low	This alarm indicates the transmitter is configured for an IBOC mode of operation and the controller has not received any communication from the Exgine over a set period of time. The alarm will clear if the transmitter is configured for a non-IBOC mode of operation, or the controller receives a response from the Exgine. If the Exgine is operating normally, ignore this alarm. If the Exgine is not operating normally, cycle ac power to the transmitter. If the alarm persists, inspect the cabling between the Exgine and the transmitter controller. If the cabling is acceptable and the alarm persists, replace the Exgine PWB see <a href="#">"Exgine PWB Replacement"</a> on page 4.1.74). If the alarm persists, replace the control/interface PWB (see <a href="#">"Control/Interface PWB Removal/Replacement"</a> on page 4.1.65).

Table 4.1.1: Troubleshooting Controller Alarms

Controller Alarm Name (AUI/UI)	Severity	Description and Troubleshooting Action
External PDM Inhibit (External Inhibit)	High	This alarm occurs if the external PDM inhibit circuit, wired to the control/ interface PWB, is closed. When this alarm occurs, the transmitter immediately inhibits the PDM and the transmitter's output power drops to 0 W. The transmitter will automatically recover when the condition is cleared. Ensure the transmitter is set to RF Off and disconnect the PDM inhibit circuit from the transmitter. Measure the impedance of the interlock circuit. If the impedance measures short circuit (low impedance) the PDM inhibit is closed, and it will be necessary to locate the external device that is causing this condition. If the impedance does not measure short circuit, verify the PDM inhibit circuitry has been properly configured. If the PDM inhibit circuitry is properly configured and the alarm persists, replace the control PWB (see <a href="#">"Control/Interface PWB Removal/Replacement"</a> on page 4.1.65). See also <a href="#">"Controller: External PDM Inhibit"</a> on page 4.1.46.
External Reset	Medium	This alarm is only visible in the transmitter logs, and indicates the controller was reset by triggering the controller's reset pin. If this alarm continues to occur unexpectedly, replace the control/interface PWB (see <a href="#">"Control/Interface PWB Removal/Replacement"</a> on page 4.1.65).
Fast SWR Shutback	High	This alarm indicates the peak reflected power measured by the directional coupler at the output of the transmitter has exceeded the factory-set threshold. When this alarm occurs, the transmitter immediately inhibits the PDM and RF drive (see Shutback on page 3.1.10 of the Operations & Maintenance Manual for a description of the shutback routine). Once the fault clears, the transmitter will automatically recover, either to the power setpoint, or to a reduced power as determined by the cutback routine (see Cutback on page 3.1.11 of the Operations & Maintenance Manual for a description of the cutback routine). If this alarm occurs in conjunction with the Exciter's SWR Shutback alarm, it generally indicates a fault in the transmitter's external RF output network (e.g., rigid-line, antenna, etc.). If this alarm is occurring while the Exciter's SWR Shutback alarm is not, verify the wiring between the directional coupler and the control/interface PWB is not damaged. If not, verify the Fast SWR Shutback threshold is set properly (contact Nautel to obtain the correct setting for your transmitter). If this threshold is set correctly and the alarm persists, replace the control/ interface PWB (see <a href="#">"Control/Interface PWB Removal/Replacement"</a> on page 4.1.65). If the alarm continues to persist, replace the directional coupler assembly (see <a href="#">"Directional Coupler Replacement"</a> on page 4.1.87).

Table 4.1.1: Troubleshooting Controller Alarms

Controller Alarm Name (AUI/UI)	Severity	Description and Troubleshooting Action
GPS Not Responding (GPS Offline)	Medium	This alarm indicates the transmitter is configured to use a GPS sync PWB as a frequency and phase reference, but the controller is not receiving communication from the GPS sync PWB. The alarm will clear when the transmitter is configured to not use the GPS sync PWB as the frequency and phase reference, or the controller receives communication from the GPS sync PWB. Inspect the wiring between the GPS sync PWB and the control/interface PWB, if applicable. If the wiring is acceptable, replace the GPS sync PWB (see <a href="#">"GPS Sync PWB Replacement"</a> on page 4.1.74).
GPS PLL Unlocked	Medium	This alarm indicates the timing phase-lock-loop between the 1 PPS signal from the GPS and the 10 MHz reference is not locked. This can occur due to a power failure, or because the GPS receiver is not locked to the GPS satellites. Verify the GPS antenna is installed and is located in a spot where it is possible to obtain a GPS satellite lock. If the alarm persists, replace the GPS sync PWB (see <a href="#">"GPS Sync PWB Replacement"</a> on page 4.1.74).
GPS Receiver Not Responding (GPS Rcvr Offline)	Medium	This alarm occurs when the GPS receiver is not responding to serial commands on the GPS sync PWB. When this occurs, the GPS sync PWB's phase-lock-loop will not be locked, and the timing signals will be free-running. Cycle (turn off, then on) the ac power to the transmitter. If the alarm persists, replace the GPS sync PWB (see <a href="#">"GPS Sync PWB Replacement"</a> on page 4.1.74).
GPS Sync No 1-PPS (GPS No 1-PPS)	Medium	The alarm occurs when the 1 PPS output from the GPS receiver is not present. This occurs when the GPS receiver is not locked to the GPS satellites. When the 1 PPS input is not present, the phase-lock-loop cannot lock properly to discipline the 10 MHz reference. Verify the GPS antenna is installed and is located in a spot where it is possible to obtain a GPS satellite lock. If the alarm persists, replace the GPS sync PWB (see <a href="#">"GPS Sync PWB Replacement"</a> on page 4.1.74).
GPS Unlocked	Medium	This alarm occurs when the GPS module on the GPS sync PWB does not have a valid satellite lock. When this alarm occurs, the phase-lock-loop is no longer running to discipline the 10 MHz oscillator, and it is allowed to free-run at the last valid setting. Verify the GPS antenna is installed and is located in a spot where it is possible to obtain a GPS satellite lock. If the alarm persists, replace the GPS sync PWB (see <a href="#">"GPS Sync PWB Replacement"</a> on page 4.1.74).

Table 4.1.1: Troubleshooting Controller Alarms

Controller Alarm Name (AUI/UI)	Severity	Description and Troubleshooting Action
High RF Drive	Low	This alarm indicates the controller's RF Drive Duty Cycle meter has risen above 60% for longer than 10 seconds. This alarm will cause an exciter changeover, if automatic changeover is enabled and the transmitter is operating on the main exciter. If there are two exciters in the transmitter, swap exciter positions. If the alarm follows the exciter, or there is only one exciter in the system, replace the digital AM exciter PWB (see <a href="#">"Digital AM Exciter PWB Replacement"</a> on page 4.1.69). If the alarm persists or the alarm remains with the position, replace the control/interface PWB. (see <a href="#">"Control/Interface PWB Removal/Replacement"</a> on page 4.1.65).
Host Network Down	Low	This alarm indicates the transmitter is configured to have networking enabled, but the host is indicating there is no network connectivity. If the transmitter is not connected to a network, the alarm can be inhibited by changing the network settings to static IP and setting the IP address to 0.0.0.0. If the transmitter is connected to a network, verify the network settings are configured properly, and the network cable is connected to the correct port on the transmitter.
Host Not Booted	Medium	This alarm indicates that the controller has not received any communication from the host since the last time the controller booted (i.e., was powered up). The occurrence of this alarm is normal for approximately one to five minutes while the host is booting, immediately after ac power has been applied to the transmitter. If this alarm continues to occur more than 30 minutes after ac power has been applied to the transmitter, cycle (turn off, then on) the ac power. If the alarm persists after 30 minutes, replace the control/interface PWB (see <a href="#">"Control/Interface PWB Removal/Replacement"</a> on page 4.1.65).
Host Not Responding	Medium	This alarm indicates that the controller has not received any communication from the host in a set period of time. The occurrence of this alarm is normal for approximately one to five minutes while the host is booting, immediately after ac power has been applied to the transmitter. If this alarm continues to occur more than 30 minutes after ac power has been applied to the transmitter, cycle (turn off, then on) the ac power. If the alarm persists after 30 minutes, replace the control/interface PWB. (see <a href="#">"Control/Interface PWB Removal/Replacement"</a> on page 4.1.65).
Internal Watchdog Reset	Medium	This alarm will only be seen in transmitter logs, and indicates that the controller was reset by its internal watchdog. If this alarm persists, replace the control/interface PWB (see <a href="#">"Control/Interface PWB Removal/Replacement"</a> on page 4.1.65).

Table 4.1.1: Troubleshooting Controller Alarms

Controller Alarm Name (AUI/UI)	Severity	Description and Troubleshooting Action
Interlock Open	High	<p>This alarm indicates that the external interlock input wired to the control/interface PWB is open. An alarm will be triggered by user-set conditions (e.g., the state of the door to the ATU). When this alarm occurs, the transmitter immediately inhibits the PDM and the transmitter's output power drops to 0 W. If this condition persists for more than 10 seconds, the transmitter will inhibit the RF power modules, fans and B+ power supply. The transmitter will automatically recover when the condition is cleared. With the transmitter set to RF Off, disconnect the interlock circuit from the transmitter. Measure the impedance of the interlock circuit. If the impedance measures open circuit (high impedance) the interlock is open, and it will be necessary to locate the external device that is causing this condition. If the impedance does not measure open circuit, verify the interlock circuitry has been properly configured. If the interlock circuitry is properly configured, make a temporary jumper and use it to short out the interlock circuit. If the alarm disappears, the transmitter is operating as expected and it will be necessary to locate the external device that is causing this condition. If the alarm persists, replace the control PWB (see <a href="#">"Control/Interface PWB Removal/Replacement"</a> on page 4.1.65). See also <a href="#">"Controller: Interlock Open"</a> on page 4.1.46.</p>
Jumped to Bootloader Code (Jump to Bootloader)	Medium	<p>This alarm is only visible in the transmitter logs, and indicates the controller was reset due to performing a firmware upgrade. If this alarm is occurring when a firmware upgrade is not being performed, replace the control/interface PWB (see <a href="#">"Control/Interface PWB Removal/Replacement"</a> on page 4.1.65).</p>
Local UI Failure (UI Failure)	Low	<p>This alarm indicates that the transmitter controller is not receiving any communication from the local user interface. The alarm will clear when the controller begins to receive communications from the local user interface. Inspect the wiring between the local user interface and the control/interface PWB. If the alarm persists, replace the local user interface (see <a href="#">"Graphic User Interface Display and UI Interface PWB Replacement"</a> on page 4.1.94).</p>
Low Battery	Medium	<p>This alarm occurs if the voltage of the backup battery has fallen below an acceptable level. Replace the battery (BT1) on the control/interface PWB while ac power is on. If the alarm persists after replacing the battery, replace the control/interface PWB (see <a href="#">"Control/Interface PWB Removal/Replacement"</a> on page 4.1.65).</p>



Table 4.1.1: Troubleshooting Controller Alarms

Controller Alarm Name (AUI/UI)	Severity	Description and Troubleshooting Action
Low RF Drive	Low	This alarm indicates the controller's RF Drive Duty Cycle meter has fallen below 40% for longer than 10 seconds. This alarm will cause an exciter changeover, if automatic changeover is enabled and the transmitter is operating on the main exciter. If there are two exciters in the transmitter, swap exciter positions. If the alarm follows the exciter, or there is only one exciter in the system, replace the digital AM exciter PWB (see <a href="#">"Digital AM Exciter PWB Replacement"</a> on page 4.1.69). If the alarm persists, or the alarm remains with the position, replace the control/interface PWB (see <a href="#">"Control/Interface PWB Removal/Replacement"</a> on page 4.1.65).
Out of Memory Reset	Medium	This alarm is only visible in the transmitter logs, and indicates the controller automatically reset because it ran out of the memory required to continue normal operation. If the alarm persists, replace the control/interface PWB (see <a href="#">"Control/Interface PWB Removal/Replacement"</a> on page 4.1.65).
Power Loss	Medium	This alarm indicates that the controller lost power at the time the event was logged. The alarm should occur concurrently with other alarms. Follow the troubleshooting action for the associated alarm(s). Otherwise, if the alarm persists without the presence of other alarms, replace the control/interface PWB (see <a href="#">"Control/Interface PWB Removal/Replacement"</a> on page 4.1.65).
Rack 1 Not Responding	Medium	This alarm indicates that the controller is no longer receiving serial communication from Rack 1. No action is taken. Check the wiring and connections between the control/interface PWB and the rack interface PWB and verify there is no damage. If the wiring is OK, replace the control/interface PWB (see <a href="#">"Control/Interface PWB Removal/Replacement"</a> on page 4.1.65). If the alarm persists, replace the rack interface PWB (see <a href="#">"Rack Interface PWB Replacement"</a> on page 4.1.75).
Rack Shutback	High	This alarm indicates that the rack interface has requested a shutback, but there is no information on the specific cause for the request. This alarm causes the transmitter to shut back (see Shutback on page 3.1.10 of the Operations & Maintenance Manual for a description of the shutback routine). Check the wiring and connections between the control/interface PWB and the rack interface PWB, specifically the Rack Shutback signal and the serial communication bus, and verify there is no damage. If the wiring is OK, replace the control/interface PWB (see <a href="#">"Control/Interface PWB Removal/Replacement"</a> on page 4.1.65) or the rack interface PWB (see <a href="#">"Rack Interface PWB Replacement"</a> on page 4.1.75).

*Table 4.1.1: Troubleshooting Controller Alarms*

Controller Alarm Name (AUI/UI)	Severity	Description and Troubleshooting Action
Unknown Reset Cause	Medium	This alarm is only visible in the transmitter logs, and indicates the controller was reset, but it was unable to determine the cause of the reset. If the controller is rebooting unexpectedly, check for the presence of other alarms at the time of this alarm and follow the troubleshooting action for the associated alarm(s). Otherwise, replace the control/interface PWB (see <a href="#">"Control/Interface PWB Removal/Replacement"</a> on page 4.1.65).

Table 4.1.2: Troubleshooting Exciter A/B Alarms

Exciter A/B Alarm Name (AUI/UI)	Severity	Description and Troubleshooting Action
AES 1 (or 2) Unlocked	Medium	This alarm indicates there is no AES data detected on the applicable AES (1 or 2) input and that same input is selected as the active input in either Analog or Digital settings for the active preset. Verify there is valid AES data being applied to the corresponding input on the control/interface PWB. If there is data being applied to the correct input and the alarm persists, replace the digital AM exciter PWB (see <a href="#">"Digital AM Exciter PWB Replacement"</a> on page 4.1.69) or the control/interface PWB (see <a href="#">"Control/Interface PWB Removal/Replacement"</a> on page 4.1.65).
AM Input Loss	Medium	This alarm occurs if the input signal being used to generate the analog AM modulation is low or not present. This alarm will be triggered immediately if the AES input is unlocked, or after 2 minutes if the incoming modulation level is below 10%. The presence of this alarm will trigger an exciter changeover if automatic changeover is enabled and the transmitter is operating on the main exciter. Verify that the active preset is calling up the correct audio input and is set for the correct input level. Verify that there is a valid audio signal on the audio input being used. If the alarm persists, replace the associated digital AM exciter PWB (see <a href="#">"Digital AM Exciter PWB Replacement"</a> on page 4.1.69).
Audio Loss	Medium	This alarm occurs as a result of the modulation being below the specified threshold for the designated period of time set in the remote AUI's Audio Loss tab for the current preset. This will cause the action specified in the preset to be taken. Check the audio inputs specified in the preset and verify there is signal present.
Audio Overmod Protection (Audio Overmod)	Medium	This alarm indicates that the exciter has reduced the output signal due to overmodulation on the audio input. This alarm is typically caused by low frequency or excessive modulation, although it can also occur if the DRM AES input sensitivity is incorrectly configured, resulting in too much signal level. The alarm will clear and allow the gain to return to 100% once the excessive modulation condition disappears. Check the input signal being applied to the exciter and reduce the level as necessary.

Table 4.1.2: Troubleshooting Exciter A/B Alarms

Exciter A/B Alarm Name (AUI/UI)	Severity	Description and Troubleshooting Action
B+ Sample Uncalibrated (B+ Uncalibrated)	Medium	This alarm indicates that the associated exciter's B+ sample has never been calibrated. This alarm should only occur when replacing an exciter, and indicates the configuration file was not properly uploaded (see <a href="#">"Digital AM Exciter PWB Replacement"</a> on page 4.1.69).
Carrier Sync Unlocked (Sync Unlock)	Medium	This alarm occurs when the transmitter's Sync Source is set to GPS Sync Card or Combiner and the exciter cannot lock to the 1 kHz signal used for phase synchronization. If the Sync Source is set to Combiner, this alarm will cause the transmitter to be inhibited, otherwise this alarm is displayed for information only. If the transmitter's Sync Source is set to GPS Sync Card, check the connection between the GPS sync PWB and the control/interface PWB. If the connection looks OK, replace the GPS sync PWB (see <a href="#">"GPS Sync PWB Replacement"</a> on page 4.1.74). If the alarm persists, replace the associated digital AM exciter PWB (see <a href="#">"Digital AM Exciter PWB Replacement"</a> on page 4.1.69) or the control/interface PWB (see <a href="#">"Control/Interface PWB Removal/Replacement"</a> on page 4.1.65). If the transmitter's Sync Source is set to Combiner, check the connection between the combiner and the control/interface PWB. If the connection looks OK, troubleshoot the combiner's synchronization signal source.
Cutback	Medium	The forward power has been reduced due to multiple shutbacks. See <a href="#">"Cutback:"</a> on page 3.1.11 of the Operations & Maintenance Manual for a description of the cutback routine. Check for associated alarms and refer to their troubleshooting information to determine the specific cause of the cutback.
Digital Input Loss (Dig Input Loss)	Medium	This alarm indicates the input signal being used to generate the digital modulation is too low or no longer present. This alarm will be triggered immediately if the AES input (DRM) is unlocked or the Exgine stream (IBOC) is missing, or if the DSP is receiving zeroes on the AES (DRM) or Exgine (IBOC) input for more than 100 ms. The presence of this alarm will trigger an exciter changeover, if automatic changeover is enabled and the transmitter is operating on the main exciter. Verify that the active preset is calling up the correct input and is set for the correct input level. Verify that there is a valid signal on the input being used. If the alarm persists, replace the associated digital AM exciter PWB (see <a href="#">"Digital AM Exciter PWB Replacement"</a> on page 4.1.69).

Table 4.1.2: Troubleshooting Exciter A/B Alarms

Exciter A/B Alarm Name (AUI/UI)	Severity	Description and Troubleshooting Action
Entered Firmware Upgrade (FW Upgrade)	Low	This alarm indicates that the exciter firmware is being upgraded, and it has inhibited the RF output until complete. The alarm will clear when the upgrade is complete and the exciter reboots. If a firmware upgrade has not been initialized intentionally, try resetting the exciter. If the alarm continues to persist, replace the associated digital AM exciter PWB (see <a href="#">“Digital AM Exciter PWB Replacement”</a> on page 4.1.69).
External Inhibit Active (Ext Inhibit)	Low	This alarm indicates that the transmitter controller has inhibited the exciters. Transmitter output power is reduced to 0 W. It is normal to see this alarm when the transmitter is in an RF OFF state. If this alarm occurs while RF is turned on, there should be a corresponding alarm indicated by the transmitter controller. Follow the troubleshooting information for that alarm.
FPGA Test Failed (FPGA Test Fail)	Medium	This alarm indicates there is a programming failure with the FPGA. Cycle the power (off, then on) to the transmitter. If the alarm persists, replace the associated digital AM exciter PWB (see <a href="#">“Digital AM Exciter PWB Replacement”</a> on page 4.1.69).
High B+ Voltage (High B+)	Medium	This alarm indicates that the B+ voltage measured by the exciter exceeded the B+ setpoint by more than 20 V for at least <b>ten (10)</b> seconds. If the rack interface’s High B+ voltage alarm is present, see the troubleshooting action for that alarm. If the rack interface’s alarm is not present, compare the exciter’s B+ voltage meter with the rack’s B+ voltage meter. If they are different, calibrate the exciter’s B+ voltage sample using a multimeter to measure the B+ voltage. If after calibrating the exciter’s B+ voltage sample the meters continue to read the incorrect voltage, replace the associated digital AM exciter PWB (see <a href="#">“Digital AM Exciter PWB Replacement”</a> on page 4.1.69).
High DC Current Foldback (IDC Foldback)	Medium	This alarm indicates that the transmitter’s forward power is being reduced because the total dc current being drawn from the B+ power supply, as measured by the transmitter controller’s Total B+ Current meter, exceeded 49 A. The alarm will clear once the transmitter’s forward power is no longer being reduced. This alarm indicates the transmitter’s efficiency is much lower than expected, most likely due to a poor load being presented to the RF power modules. Ensure the load impedance being presented to the transmitter by the antenna network is within specification.

*Table 4.1.2: Troubleshooting Exciter A/B Alarms*

Exciter A/B Alarm Name (AUI/UI)	Severity	Description and Troubleshooting Action
High Forward Foldback (Fwd Foldback)	Medium	This alarm occurs when the transmitter’s forward power has been reduced because the average forward power increased above 150% of the transmitter’s rated carrier power. The alarm will clear when the forward power is no longer being reduced. The alarm will generally occur due to excessive modulation. Reduce the level of modulation applied to the transmitter.
High Power Lockout (Power Lockout)	Medium	This alarm occurs when the exciter has reduced the power set point due to the currently active high power lockout limit being lower than the active preset’s power set point.
High Temperature Foldback (Temp Foldback)	Medium	This alarm indicates either the average temperature of the RF power modules has exceeded 80 degrees Celsius, or the rectifier heatsink temperature has exceeded 80 degrees Celsius, and the transmitter’s forward power is being reduced to maintain temperatures that are below the above temperature thresholds. Once the high temperature condition has cleared, it may take up to an hour for the transmitter to return to its power setpoint, and the alarm will clear when the power is no longer being reduced. Otherwise, pressing the reset button will cause the alarm to clear. Check the transmitter’s output network and verify that the air filter in the back of the cabinet is clean. Verify the temperature of the transmitter building is within specifications.
Low B+ Voltage (Low B+)	Medium	This alarm occurs when the B+ voltage measured by the exciter drops below 75% of the B+ setpoint for more than 10 seconds. When this alarm is present the exciter will not allow the PDM duty cycle to be increased to compensate for fluctuations in B+. This alarm will clear when the B+ voltage measurement exceeds 81.25% of the B+ setpoint. Generally this alarm indicates that the B+ voltage cannot be increased because the ac voltage is too low. Check the ac mains voltage connected to the transmitter and verify the power transformer is tapped correctly.
Low Forward Power Threshold 1 (or 2) (Low Forward 1 or 2)	Medium	This alarm occurs when the output power of the transmitter is below the corresponding user-defined Low Forward Power Threshold (1 or 2). This alarm should occur with other alarms indicating why the transmitter’s output power has dropped. See the troubleshooting information with associated alarms.

Table 4.1.2: Troubleshooting Exciter A/B Alarms

Exciter A/B Alarm Name (AUI/UI)	Severity	Description and Troubleshooting Action
No B+ Sample	Medium	This alarm indicates the exciter’s B+ voltage sample is below 40 V for more than 10 seconds. If there is an associated Low B+ voltage alarm, follow the troubleshooting information for that alarm. If there are no additional alarms and there is a second exciter installed, switch exciters and check if the alarm is present on the other exciter. If the alarm is present on the second exciter, check the cabling between the B+ sampling point and the control/interface PWB. If the connection is OK, replace the control/interface PWB (see <a href="#">“Control/Interface PWB Removal/Replacement”</a> on page 4.1.65). If the alarm is not present on the second exciter, or there is no second exciter in the transmitter, replace the digital AM exciter PWB (see <a href="#">“Digital AM Exciter PWB Replacement”</a> on page 4.1.69).
No Carrier Sync Signal Present (No Carrier Sync)	Medium	This alarm will occur when the transmitter’s Sync Source is set to GPS Sync Card or Combiner and the 10 MHz or 1 kHz synchronization signal is either not present or out of specification. If the Sync Source is set to Combiner, this alarm will cause the transmitter to be inhibited, otherwise this alarm is displayed for information only. If the transmitter’s Sync Source is set to GPS Sync Card, check the connection between the GPS sync PWB and the control/interface PWB. If the connection is OK, replace the GPS sync PWB (see <a href="#">“GPS Sync PWB Replacement”</a> on page 4.1.74). If the alarm persists, replace the associated digital AM exciter PWB (see <a href="#">“Digital AM Exciter PWB Replacement”</a> on page 4.1.69) or the control/interface PWB (see <a href="#">“Control/Interface PWB Removal/Replacement”</a> on page 4.1.65). If the transmitter’s Sync Source is set to Combiner, check the connection between the combiner and the control/interface PWB. If the connection looks OK, troubleshoot the combiner’s synchronization signal source.
No External 10 MHz (No Ext 10MHz)	Medium	This alarm indicates the transmitter is set to run on an external 10 MHz source, but the exciter has determined the frequency of the external source to be outside of the range 9.9 MHz to 10.1 MHz. This will cause the exciter to revert to using its internal 10 MHz reference until it determines the external 10 MHz is in range. This may also cause an exciter changeover if a backup exciter is installed and automatic changeover is enabled. Check the integrity and signal level of the external 10 MHz source. If the external source is acceptable and the alarm persists, replace the associated digital AM exciter PWB (see <a href="#">“Digital AM Exciter PWB Replacement”</a> on page 4.1.69).

Table 4.1.2: Troubleshooting Exciter A/B Alarms

Exciter A/B Alarm Name (AUI/UI)	Severity	Description and Troubleshooting Action
No Host Audio	Medium	This alarm indicates there is no audio modulation being provided by the audio player when the transmitter configured to run using the audio player as the audio source. This alarm will trigger the AM Input Loss alarm. Verify the transmitter is intentionally running with the audio player as the analog audio source. Verify the audio player is configured to play audio files, those files are present on a USB flash drive connected to the transmitter, and the audio player is playing. If the alarm persists, replace the associated digital AM exciter PWB (see <a href="#">"Digital AM Exciter PWB Replacement"</a> on page 4.1.69) or the control/interface PWB (see <a href="#">"Control/Interface PWB Removal/Replacement"</a> on page 4.1.65).
No IBOC Data	Medium	This alarm indicates there is no modulation data being provided by the embedded Exgine when the transmitter is running in an IBOC mode of operation. This alarm will trigger the Digital Input Loss alarm. Verify the transmitter is operating in the intended mode. Verify the embedded Exgine is connected to the control/interface PWB and the wiring connections are intact. Verify the Exporter is connected to the Exgine and the Exgine is receiving data from the Exporter. If the alarm persists, replace the associated digital AM exciter PWB (see <a href="#">"Digital AM Exciter PWB Replacement"</a> on page 4.1.69) or the Exgine PWB (see <a href="#">"Exgine PWB Replacement"</a> on page 4.1.74).
Over-Current Shutback (RF I Shutback)	High	This alarm indicates the peak RF current at the output of the transmitter has exceeded the Peak RF Current Limit. This alarm causes the transmitter to immediately shut down its RF output and then recover. If this alarm occurs in conjunction with the Controller's Fast SWR Shutback alarm, there may be a fault in the transmitter's external RF output network (i.e, rigid-line, antenna, etc.). If this alarm is occurring without the presence of the Controller's Fast SWR Shutback alarm, verify the RF current sample, RF voltage sample and the wiring between the sample point and the control/interface PWB is not damaged. If the alarm persists, replace the associated digital AM exciter PWB (see <a href="#">"Digital AM Exciter PWB Replacement"</a> on page 4.1.69).



Table 4.1.2: Troubleshooting Exciter A/B Alarms

Exciter A/B Alarm Name (AUI/UI)	Severity	Description and Troubleshooting Action
PLL Unlocked	High	This alarm indicates the exciter's phase lock loop, which locks the transmitter's carrier frequency to a 10 MHz reference, is no longer locked to the reference. If an external 10 MHz source is being used, the exciter will fall back to using its internal 10 MHz clock. Otherwise, the exciter will inhibit its output. If an external 10 MHz source is being used, check the integrity and signal level of the source. If the alarm persists, replace the associated digital AM exciter PWB (see <a href="#">"Digital AM Exciter PWB Replacement"</a> on page 4.1.69).
Power Below Setpoint (Pwr Below Set)	Medium	This alarm indicates that the transmitter cannot achieve the desired output power. For the alarm to occur, the power must be at least 10% below the setpoint for more than four (4) seconds, and the exciter is not able to increase the output power because it has reached maximum gain, or the output is being limited by a foldback condition. The alarm is typically accompanied by other alarms. See the troubleshooting action for the associated alarms
Precorrection Inhibited (Correction Off)	Medium	This alarm indicates that the exciter has disabled its pre-correction compensation. This alarm will occur because the transmitter's B+ voltage is too low. See the troubleshooting action for the associated low B+ voltage alarm.
Protection Mechanisms Disabled (Protection Off)	Medium	This alarm indicates that the exciter's protection (shutback, foldback, cutback) has been turned off by the user. The state should only be required when calibrating the transmitter after a frequency change. If this state is not intentional, press the reset button on the associated digital AM exciter PWB. If the alarm persists, replace the associated digital AM exciter PWB (see <a href="#">"Digital AM Exciter PWB Replacement"</a> on page 4.1.69).
Reboot for Settings Needed (Reboot Needed)	Medium	This alarm indicates that the exciter needs to reboot itself to reconfigure its settings. The exciter should automatically reboot itself, however if the alarm persists, press the reset button on the associated digital AM exciter PWB. If the alarm persists, replace the associated digital AM exciter PWB (see <a href="#">"Digital AM Exciter PWB Replacement"</a> on page 4.1.69)..
RF Probes Uncalibrated (RF Uncalibrated)	High	This alarm indicates that the associated exciter has not been calibrated for the transmitter's current operating frequency. If the operating frequency has been changed inadvertently, change the frequency back to its original setting. If a frequency change has been performed, recalibrate the exciter per the Nautel provided frequency change procedure.

Table 4.1.2: Troubleshooting Exciter A/B Alarms

Exciter A/B Alarm Name (AUI/UI)	Severity	Description and Troubleshooting Action
SWR Foldback	Medium	This alarm indicates the average reflected power has exceeded the acceptable limit, and the transmitter’s RF output is being reduced to maintain the maximum acceptable reflected power. This alarm normally occurs due to a poor impedance being presented to the transmitter. Inspect the antenna network and check the tuning to ensure the impedance being presented to the transmitter is within specification.
SWR Shutback	High	This alarm indicates the transmitter’s peak reflected power has exceeded the factory set peak reflected limit. This alarm causes the transmitter to immediately shut down its RF output, then recover. If this alarm occurs in conjunction with the Controller’s Fast SWR Shutback alarm, it generally indicates a fault in the transmitter’s external RF output network (e.g., rigid-line, antenna, etc.). If this alarm occurs without the presence of the Controller’s Fast SWR Shutback alarm, verify the RF current sample, RF voltage sample and the wiring between the sample point and the control/ interface PWB is not damaged. If the alarm persists, replace the associated digital AM exciter PWB (see <a href="#">“Digital AM Exciter PWB Replacement”</a> on page 4.1.69).
Transmitter Gain Too Low (TX Gain Low)	High	This alarm occurs when the power gain of the transmitter falls below 63%. This alarm is latching and requires pressing the reset button to clear the alarm. This alarm normally occurs because there is a significant number (greater than 37%) of disabled power modules. Try resetting transmitter alarms to clear power module faults. If the alarm persists, repair or replace RF power modules to clear this alarm (see <a href="#">“Troubleshooting RF Power Modules”</a> on page 4.1.57).
Transmitter Type Not Set (TX Type Not Set)	High	This alarm indicates that the associated exciter has not been informed of the type of transmitter it has been installed in. If the affected exciter is a replacement, follow the digital AM exciter PWB replacement procedure to clear the alarm (see <a href="#">“Digital AM Exciter PWB Replacement”</a> on page 4.1.69).
Unsigned DSP Image (Unsigned DSP)	High	This alarm indicates that the software installed on the exciter is invalid or corrupt and it is inhibiting its output. Try pressing the reset button on the digital AM exciter PWB. If the alarm persists, perform a software upgrade on the transmitter. If the alarm persists, replace the associated digital AM exciter PWB (see <a href="#">“Digital AM Exciter PWB Replacement”</a> on page 4.1.69).

*Table 4.1.2: Troubleshooting Exciter A/B Alarms*

Exciter A/B Alarm Name (AUI/UI)	Severity	Description and Troubleshooting Action
Unsigned FPGA Image (Unsigned FPGA)	High	This alarm indicates that the software installed on the exciter is invalid or corrupt. Press the reset button on the digital AM exciter PWB. If the alarm persists, perform a software upgrade on the transmitter. If the alarm persists, replace the associated digital AM exciter PWB (see <a href="#">“Digital AM Exciter PWB Replacement”</a> on page 4.1.69).

Table 4.1.3: Troubleshooting Exgine Alarms

Exgine Alarm Name (AUI/UI)	Severity	Description and Troubleshooting Action
AM/FM Mode Mismatched (Mode Mismatch)	Medium	This alarm indicates the Exporter mode does not match the Exgine mode. Reconfigure the Exporter or Exgine to the correct mode.
DPLL Unlocked	Medium	This alarm occurs when the Exgine phase-locked loop can no longer follow the reference input within 1 ppm of its calibrated value. When using Ethernet sync, this can be triggered by excessive jitter on the Ethernet link or a sudden change in throughput delay of the E2X signal path (e.g., switched IP circuits). This alarm can be temporary, in this case, once the delay has been compensated for and a new equilibrium has been found. This alarm can also be caused by Exgine crystal aging, which can be resolved by recalibrating the Exgine crystal. Ensure the alarm is not temporary and persists for at least one (1) hour. Verify the disciplining input (Exporter clock) is correct. If Exgine crystal aging is suspected, widen the VCXOPPM limits to 5 ppm. Restart the system, operate for 24 hours and ensure the alarm clears. Configure the calibrated VCXO value with the new DAC value as reported from the Exgine status screen. Set the limits back to 0.95 ppm. Restart the system and ensure the alarm is cleared.
Lost External 10MHz (Lost Ext 10MHz)	Medium	This alarm is occurs when the Exgine's external 10 MHz signal disappears during an active E2X connection. When this alarm is present, the Exgine will run on the internal oscillator. This can eventually lead to diversity delay drifts and FIFO Overflow or Underflow conditions. If an external 10 MHz signal is being intentionally applied to the Exgine, verify a valid 10 MHz signal is being applied to the Exgine. If an external 10 MHz signal is not being applied to the Exgine, cycle (turn off, then on) ac power to the transmitter. If the alarm persists in either condition, replace the Exgine PWB (see <a href="#">"Exgine PWB Replacement"</a> on page 4.1.74).
Network Down	Medium	This alarm indicates the Exgine has no network connectivity. Verify the Exgine's network settings are configured properly, and the network cable is connected to the correct port on the Exgine PWB.
Network Misconfigured	Medium	This alarm indicates that invalid Exgine network parameters have been configured. Review and correct all exgine network settings including the IP address, netmask and gateway.
System Error	Medium	This alarm acts as a summary alarm for a number of unexpected Exgine system conditions, such as failed memory checks or internal configuration errors. Contact Nautel Customer Service to troubleshoot this issue.

Table 4.1.4: Troubleshooting RF Power Module Alarms

Module Alarm Name (AUI/UI)	Severity	Description and Troubleshooting Action
+15V Fail	Medium	This alarm indicates the RF power module's +15 V power supply is below +13.5 V or above +16.5 V. This alarm will cause the RF power module to be immediately disabled. If other alarms are present at the same time this alarm is active, see the troubleshooting action for the associated alarms. Otherwise, replace the RF power module (see <a href="#">"Removing and Reinstalling RF Power Modules"</a> on page 4.1.52).
EEPROM Failure (EEPROM Fail)	Medium	This alarm indicates the RF power module was not able to load valid data from its EEPROM. Try removing and re-inserting the RF power module. If the alarm persists, replace the RF power module (see <a href="#">"Removing and Reinstalling RF Power Modules"</a> on page 4.1.52).
External Disable Active (Ext. Disable)	Medium	This alarm indicates the PDM cable has been disconnected from the front of the RF power module, which causes the power module to be immediately disabled. If this alarm occurs, reconnect the PDM drive cable associated with that RF power module. If the problem persists, swap the affected RF power module with an operational RF power module's position. If the fault follows the RF power module, replace the RF power module (see <a href="#">"Removing and Reinstalling RF Power Modules"</a> on page 4.1.52). If the fault remains with the position, try replacing the PDM drive cable. If the alarm persists, replace the source of the PDM signal (see <a href="#">"Digital AM Exciter PWB Replacement"</a> on page 4.1.69 or <a href="#">"Control/Interface PWB Removal/Replacement"</a> on page 4.1.65).
Front Panel Inhibit (User Inhibit)	Medium	This alarm indicates that the RF power module has been disabled through the front panel user interface. If this alarm is present, attempt to enable the RF power module through the front panel user interface.
High B+ Voltage (High B+)	Medium	This alarm indicates the RF power module's B+ meter has exceeded 450 V. If high B+ voltage alarms are present for other system components, see the troubleshooting action for those alarms. If the alarm persists, replace the RF power module (see <a href="#">"Removing and Reinstalling RF Power Modules"</a> on page 4.1.52).

Table 4.1.4: Troubleshooting RF Power Module Alarms

Module Alarm Name (AUI/UI)	Severity	Description and Troubleshooting Action
High DC Current (High DC I)	Medium	This alarm indicates that the RF power module's DC Current meter has exceeded 22 A, or the RF power module's peak DC current has exceeded the threshold applied to the microcontroller's comparator. This alarm will immediately disable the RF power module, and latch it off. If this alarm occurred in conjunction with an Overmodulation alarm, follow the troubleshooting action for that alarm. Otherwise, try resetting the alarms using the front panel UI or the remote AUI. If the alarm persists, replace the RF power module (see <a href="#">"Removing and Reinstalling RF Power Modules" on page 4.1.52</a> ). If the alarm clears, troubleshoot the suspect RF power module for RF FET failures (see <a href="#">"Troubleshooting RF Power Modules" on page 4.1.57</a> ) or the associated gas discharge tube has activated. If the alarm persists, suspect that the associated RF relay is not opening (see <a href="#">"Gas Discharge PWB and Relay Replacement" on page 4.1.79</a> ).
High PA Voltage (High PAV)	Medium	This alarm occurs because of one of two conditions: (1) the PA voltage is at least 10% above the product of the B+ level and the PDM duty cycle; or (2) the PA voltage has exceeded 95% of the B+ value for more than 50 ms. The alarm is latching and will cause the associated RF power module to disable itself. This alarm generally indicates that a modulator FET has failed. See <a href="#">"Troubleshooting RF Power Modules" on page 4.1.57</a> to determine whether to replace the affected RF power module or to repair damaged parts.
High RF Drive (High RF Drv)	Medium	This alarm indicates the RF drive duty cycle as measured by the RF power module is above 65%. The affected RF power module is immediately disabled. Try swapping the affected RF power module with an operational RF power module in another position. If the fault follows the RF power module, replace the RF power module (see <a href="#">"Removing and Reinstalling RF Power Modules" on page 4.1.52</a> ). If the fault remains with that position, replace the rack interface PWB (see <a href="#">"Rack Interface PWB Replacement" on page 4.1.75</a> ) or associated RF power module interface PWB (see <a href="#">"Power Module Interface PWB Replacement" on page 4.1.77</a> ). If the alarm is present on all RF power modules, try replacing the RF drive cable. If the alarm persists, replace the control/interface PWB (see <a href="#">"Control/Interface PWB Removal/Replacement" on page 4.1.65</a> ) or the associated digital AM exciter PWB (see <a href="#">"Digital AM Exciter PWB Replacement" on page 4.1.69</a> ).

Table 4.1.4: Troubleshooting RF Power Module Alarms

Module Alarm Name (AUI/UI)	Severity	Description and Troubleshooting Action
High Temperature (High Temp)	Medium	This alarm indicates the power module's measured heatsink temperature has exceeded 90 degrees Celsius. The affected RF power module is immediately disabled. If this alarm occurs with another alarm, troubleshoot that alarm first. Otherwise, see <a href="#">"Troubleshooting RF Power Modules"</a> on page 4.1.57 to determine whether to replace the affected RF power module or to repair damaged parts.
Invalid Thermistor Sample (Therm. Fault)	Medium	This alarm indicates there is a problem with the associated RF power module's temperature sample. When this alarm occurs, the associated RF power module will disable itself until the condition is cleared. Inspect R1 on the RF power module, which is soldered to pads G and H of A1, and repair or replace as necessary. Otherwise replace the entire RF power module (see <a href="#">"Removing and Reinstalling RF Power Modules"</a> on page 4.1.52).
Low B+ Voltage (Low B+)	Medium	This alarm indicates the B+ level of the associated RF power module is below 75% of its nominal value. If the Rack Interface's Low B+ Voltage alarm is present, follow the troubleshooting action for that alarm. Try swapping the affected RF power module with an operational RF power module in another position. If the fault follows the RF power module, replace the RF power module (see <a href="#">"Removing and Reinstalling RF Power Modules"</a> on page 4.1.52). If the fault remains with that position, check the B+ fuse associated with the RF power module and replace as necessary (see <a href="#">"RF Module #: Low B+ Voltage"</a> on page 4.1.50).
Low Fan 1 (or 2) Speed (Fan 1 or 2 Fault)	Medium	This alarm occurs if the RF power module is expected to produce RF power and the fan (1 or 2) tachometer drops below 1650 RPM. The affected RF power module is immediately disabled. Try swapping the affected RF power module with an operational RF power module in another position. If the fault follows the RF power module, replace the RF power module (see <a href="#">"Removing and Reinstalling RF Power Modules"</a> on page 4.1.52). If the fault remains with that position, replace the associated fan tray assembly (see <a href="#">"Fan Tray Replacement"</a> on page 4.1.81). If the alarm persists, replace the associated power module interface PWB (see <a href="#">"Power Module Interface PWB Replacement"</a> on page 4.1.77).

Table 4.1.4: Troubleshooting RF Power Module Alarms

Module Alarm Name (AUI/UI)	Severity	Description and Troubleshooting Action
Low PA Voltage (Low PAV)	Medium	This alarm indicates the RF power module's PA Voltage meter has dropped 10% below the expected value - determined by multiplying the power module's B+ Voltage meter by the PDM Duty Cycle meter - for more than 500 ms. This alarm can only be triggered if the RF power module PDM Duty Cycle meter is above 10%, causing the affected RF power module to be immediately disabled, and latched. Try resetting the alarm using the front panel UI or remote AUI. If the alarm persists, replace the affected RF power module (see <a href="#">"Removing and Reinstalling RF Power Modules" on page 4.1.52</a> ).
Low RF Drive	Medium	This alarm indicates the RF drive duty cycle of the affected RF power module is below 35%. The affected RF power module is immediately disabled. Try swapping the affected RF power module with an operational RF power module in another position. If the fault follows the RF power module, replace the RF power module (see <a href="#">"Removing and Reinstalling RF Power Modules" on page 4.1.52</a> ). If the fault remains with that position, replace the rack interface PWB (see <a href="#">"Rack Interface PWB Replacement" on page 4.1.75</a> ) or associated RF power module interface PWB (see <a href="#">"Power Module Interface PWB Replacement" on page 4.1.77</a> ). If the alarm is present on all RF power modules, try replacing the RF drive cable. If the alarm persists, replace the control/interface PWB (see <a href="#">"Control/Interface PWB Removal/Replacement" on page 4.1.65</a> ) or the associated digital AM exciter PWB (see <a href="#">"Digital AM Exciter PWB Replacement" on page 4.1.69</a> ).
No Controller Communications (No Comms)	Medium	This alarm indicates the RF power module has not received any communication from the rack interface for 10 seconds. Try swapping the affected RF power module with an operational RF power module in another position. If the alarm follows the RF power module, replace the RF power module (see <a href="#">"Removing and Reinstalling RF Power Modules" on page 4.1.52</a> ). If the alarm remains with the position, replace the rack interface PWB (see <a href="#">"Rack Interface PWB Replacement" on page 4.1.75</a> ) or the power module interface PWB (see <a href="#">"Power Module Interface PWB Replacement" on page 4.1.77</a> ).



Table 4.1.4: Troubleshooting RF Power Module Alarms

Module Alarm Name (AUI/UI)	Severity	Description and Troubleshooting Action
Overmodulation (Overmod)	Medium	This alarm indicates the RF power module's PDM Duty Cycle meter is above 95%. Verify the modulation being applied to the transmitter is not too high. Try swapping the RF power module with an RF power module that is not showing this alarm. If the alarm follows the RF power module, replace the RF power module (see <a href="#">"Removing and Reinstalling RF Power Modules"</a> on page 4.1.52). If the alarm remains with the original position, try replacing the digital AM exciter PWB (see <a href="#">"Digital AM Exciter PWB Replacement"</a> on page 4.1.69) or the control/interface PWB (see <a href="#">"Control/Interface PWB Removal/Replacement"</a> on page 4.1.65).
Residual PA Voltage Present (Residual PAV)	Medium	This alarm indicates the PA voltage of the RF power module is higher than expected with either the modulator or the RF amplifier disabled. See <a href="#">"Troubleshooting RF Power Modules"</a> on page 4.1.57 to determine whether to replace the affected RF power module or to repair damaged parts, suspecting a failure of one of the FETs.
RF Drive Fault (RF Drv Fault)	Medium	This alarm indicates that the duty cycle of the RF drive or the dead time between RF drive signals on the associated RF power module is not as expected. This alarm causes the RF power module to be immediately disabled and latched off. Try resetting the alarm using the front panel UI or the remote AUI. Try swapping the affected RF power module with an operational RF power module in another position. If the fault follows the RF power module, replace the RF power module (see <a href="#">"Removing and Reinstalling RF Power Modules"</a> on page 4.1.52). If the fault remains with that position, replace the rack interface PWB (see <a href="#">"Rack Interface PWB Replacement"</a> on page 4.1.75) or associated RF power module interface PWB (see <a href="#">"Power Module Interface PWB Replacement"</a> on page 4.1.77). If the alarm is present on all RF power modules, try replacing the RF drive cable. If the alarm persists, replace the control/interface PWB (see <a href="#">"Control/Interface PWB Removal/Replacement"</a> on page 4.1.65) or the associated digital AM exciter PWB (see <a href="#">"Digital AM Exciter PWB Replacement"</a> on page 4.1.69).

Table 4.1.5: Troubleshooting Rack Alarms

Rack Alarm Name (AUI/UI)	Severity	Description and Troubleshooting Action
+15 V Fail	Medium	This alarm occurs if the +15 V rail is outside the acceptable range (13.5 V to 16.5 V). Measure the output voltage of the +15 V power supply. If it is outside the acceptable range, replace the +15 V power supply (see <a href="#">“+15 V or +48 V Power Supply Replacement”</a> on page 4.1.92). Otherwise check the continuity of the cabling between the power supply and the rack interface PWB and repair as necessary. If the cabling is OK, replace the rack interface PWB (see <a href="#">“Rack Interface PWB Replacement”</a> on page 4.1.75).
+30 V Fail	Medium	This alarm occurs if the +30 V rail is outside the acceptable range (27 V to 33 V). Replace the rack interface PWB (see <a href="#">“Rack Interface PWB Replacement”</a> on page 4.1.75).
+48 V Fail	Medium	This alarm occurs if the +48 V rail is outside the acceptable range (44 V to 52 V). Measure the output voltage of the +48 V power supply. If it is outside the acceptable range, replace the +48 V power supply (see <a href="#">“Graphic User Interface Display and UI Interface PWB Replacement”</a> on page 4.1.94). Otherwise check the continuity of the cabling between the power supply and the rack interface PWB and repair as necessary. If the cabling is OK, replace the rack interface PWB (see <a href="#">“Rack Interface PWB Replacement”</a> on page 4.1.75).
-15 V Fail	Medium	This alarm occurs if the -15 V rail is outside the acceptable range (-13.5 V to -16.5 V). Suspect a faulty dc-dc converter (U5) on the rack interface PWB. Remove the rack interface PWB (see <a href="#">“Rack Interface PWB Replacement”</a> on page 4.1.75) and replace the defective dc-dc converter or the entire rack interface PWB.
AC Phase Loss	Medium	This alarm occurs when the SCR rectifier assembly detects a significant imbalance in the ac phase voltages. The rectifier will shut down when this condition exists and prevent the transmitter from generating RF. In a safe manner, measure the voltage of each phase of the ac mains. If a phase is missing, check the ac mains fuses. If the ac mains phases are normal and the alarm persists, check the Phase Loss LED on the rectifier. If it is on, replace the SCR rectifier (see <a href="#">“SCR Rectifier Inspection/Replacement”</a> on page 4.1.67). If the Phase Loss LED is off, replace the rack interface PWB (see <a href="#">“Rack Interface PWB Replacement”</a> on page 4.1.75).
Arc Detector 1	High	This alarm indicates that the transmitter’s arc detector has detected an arc and caused the transmitter to shut back. Due to the sensitivity of the arc detector, it is possible for an external UV source to cause this alarm. Check and remove all external UV sources. If the alarm persists, perform a visual inspection inside the rear of the transmitter for signs of corona or arcing.

Table 4.1.5: Troubleshooting Rack Alarms

Rack Alarm Name (AUI/UI)	Severity	Description and Troubleshooting Action
EEPROM Failure (EEPROM Fail)	Medium	This alarm indicates that the rack controller has failed to load its configuration from EEPROM. Remove and reapply the ac power to the transmitter. If the alarm persists, replace the rack interface PWB (see <a href="#">"Rack Interface PWB Replacement"</a> on page 4.1.75).
High AC Voltage (High AC)	Medium	This alarm indicates the rack interface's Ac Sample meter is above 384 V. The alarm clears when the sample falls below this voltage. It can be caused by an improperly tapped power transformer or a transient on the ac mains. Verify the mains transformer is tapped correctly (see <a href="#">Step 11</a> of <a href="#">"Connecting Ac Power"</a> in the Installation Manual). If so, monitor the ac mains for transient conditions when this alarm occurs.
High B+ Shutback (Hi B+ Shutback)	High	This alarm occurs when the B+ voltage measured by the rack interface exceeds the set threshold (normally 430 V). This causes the transmitter to disable the B+ power supply until the B+ voltage has decreased an additional 15 volts below the threshold. This alarm normally occurs with extreme changes in transmitter power (i.e., preset changes, interlock open, etc.). If the alarm is occurring continuously, or when unexpected, monitor the B+ with an oscilloscope and determine if the B+ is exceeding the shutback limit. If it is not exceeding the limit, replace the rack interface PWB (see <a href="#">"Rack Interface PWB Replacement"</a> on page 4.1.75). If it is exceeding the limit, verify the ac mains transformer is tapped correctly (see <a href="#">Step 11</a> of <a href="#">"Connecting Ac Power"</a> in the Installation Manual).
High B+ Voltage (High B+)	Medium	If the B+ voltage is more than 10 V above the B+ voltage set point, the rack interface will attempt to decrease the rectifier's output. If the rack interface reaches the bottom of its adjustment range and the B+ voltage remains 10 V or more above the B+ voltage setpoint for more than 15 seconds, this alarm will occur. The alarm will clear when the B+ voltage changes to within 10 V of the B+ voltage setpoint, or the B+ power supply is inhibited (by turning RF Off, for example). If the alarm persists while the transmitter is producing RF power, check the ac mains voltages and verify they are within $\pm 10\%$ of the nominal voltage for which the transformer is tapped. Verify the mains transformer is tapped correctly (see <a href="#">Step 11</a> of <a href="#">"Connecting Ac Power"</a> in the Installation Manual). If the alarm persists, replace the rectifier assembly (see <a href="#">"SCR Rectifier Inspection/Replacement"</a> on page 4.1.67) or the rack interface PWB (see <a href="#">"Rack Interface PWB Replacement"</a> on page 4.1.75).

Table 4.1.5: Troubleshooting Rack Alarms

Rack Alarm Name (AUI/UI)	Severity	Description and Troubleshooting Action
High Rectifier Temperature (Rectifier Temp)	Medium	This alarm indicates that the rectifier heatsink temperature has exceeded 100 degrees Celsius. The exciter should reduce the transmitter's output power before this alarm occurs (see High Temperature Foldback alarm in Table 4.1.2). The alarm will clear once the rectifier heatsink temperature drops below 99.5 degrees Celsius. The alarm indicates that there is excessive dissipation in the rectifier, likely due to high current draw. This may be due to the secondary voltage of the power transformer being lower than specified. Verify the mains transformer is tapped correctly (see Step 11 of "Connecting Ac Power" in the Installation Manual). If the alarm persists, replace the rectifier assembly (see "SCR Rectifier Inspection/Replacement" on page 4.1.67).
Low AC Voltage (Low AC)	Medium	This alarm indicates the rack interface's Ac Sample meter is below 256 V. The alarm clears when the sample rises above this voltage. It is caused by an improperly tapped transformer, or a transient on the ac mains. Verify the mains transformer is tapped correctly (see Step 11 of "Connecting Ac Power" in the Installation Manual). If so, monitor the ac mains for transient conditions when this alarm occurs.
Low B+ Shutdown	High	This alarm indicates that the B+ decreases more than 126 V below the B+ setpoint. While this alarm is active, the rectifier and exciter PDM outputs will be inhibited. This alarm will clear if the measured ac voltage on the transformer secondary increases above 263 Vac line-to-line after a minimum one (1) second delay or if the transmitter is turned RF Off. If the alarm persists, check the ac mains voltage and verify they are within the nominal voltage the transmitter is tapped for $\pm 10\%$ . Verify the mains transformer is tapped correctly (see Step 11 of "Connecting Ac Power" in the Installation Manual). With RF On at low power, verify the B+ voltage is 400 V (or per the B+ setpoint if adjusted). If not, replace the rectifier (see "SCR Rectifier Inspection/Replacement" on page 4.1.67). Otherwise suspect the rack interface PWB (see "Rack Interface PWB Replacement" on page 4.1.75).

Table 4.1.5: Troubleshooting Rack Alarms

Rack Alarm Name (AUI/UI)	Severity	Description and Troubleshooting Action
Low B+ Voltage (Low B+)	Medium	<p>If the B+ voltage falls to more than 15% below the B+ voltage set point, the rack interface will attempt to turn up the rectifier output voltage. If the rack interface reaches the top of its adjustment range and the B+ voltage remains 25% or more below the B+ voltage setpoint for more than two (2) seconds, this alarm will occur. The alarm will clear when the B+ voltage changes to within 25% of the B+ voltage setpoint, or the B+ power supply is inhibited (by turning RF Off, for example). If the alarm persists while the transmitter is producing RF power, check the main B+ fuse and replace as necessary. If the fuse is OK or the alarm persists, check the ac mains voltages and verify they are within <math>\pm 10\%</math> of the nominal voltage for which the transformer is tapped. Verify the mains transformer is tapped correctly (see <a href="#">Step 11 of "Connecting Ac Power"</a> in the Installation Manual). If the alarm persists, replace the rectifier assembly (see <a href="#">"SCR Rectifier Inspection/Replacement"</a> on page 4.1.67) or the rack interface PWB (see <a href="#">"Rack Interface PWB Replacement"</a> on page 4.1.75).</p>
Power Module 1 (or 2,3,4) Not Responding (PM 1 or 2,3,4 Offline)	Medium	<p>This alarm indicates that the rack interface PWB is not receiving a response from the associated RF power module. Try swapping the affected RF power module with an RF power module in another location. If the alarm follows the RF power module, replace the RF power module (see <a href="#">"Removing and Reinstalling RF Power Modules"</a> on page 4.1.52). If the alarm remains with the location, replace the rack interface PWB (see <a href="#">"Rack Interface PWB Replacement"</a> on page 4.1.75). If the alarm persists, replace the associated power module interface PWB (see <a href="#">"Power Module Interface PWB Replacement"</a> on page 4.1.77).</p>

Table 4.1.6: Troubleshooting Summary Alarms

Summary Alarm Name, AUI (front panel UI)	Description and Triggering Alarms																														
Audio Loss Summary (Audio Loss Summary)	<p>This summary alarm is triggered if any of the following audio loss related alarms occur:</p> <p><u>Exciter A/B alarms:</u></p> <table border="0"> <tr> <td>AES1/2 Unlocked</td> <td>Audio Loss</td> <td>No Host Audio</td> </tr> <tr> <td>AM Input Loss</td> <td>Digital Input Loss</td> <td>No IBOC Data</td> </tr> </table>	AES1/2 Unlocked	Audio Loss	No Host Audio	AM Input Loss	Digital Input Loss	No IBOC Data																								
AES1/2 Unlocked	Audio Loss	No Host Audio																													
AM Input Loss	Digital Input Loss	No IBOC Data																													
Controller Fault Summary (Controller Summary)	<p>This summary alarm is triggered if any of the following Controller related alarms occur:</p> <p><u>Controller alarms:</u></p> <table border="0"> <tr> <td>EEPROM Failure: Config</td> <td>Host Not Booted</td> <td>+1.2V Fail</td> </tr> <tr> <td>EEPROM Failure: Potentiometers</td> <td>Host Not Responding</td> <td>+3.3V Fail</td> </tr> <tr> <td>EEPROM Failure: Remotes</td> <td>Local UI Failure</td> <td>-5V Fail</td> </tr> <tr> <td>EEPROM Failure: Schedule</td> <td>Low Battery</td> <td>-15V Fail</td> </tr> </table>	EEPROM Failure: Config	Host Not Booted	+1.2V Fail	EEPROM Failure: Potentiometers	Host Not Responding	+3.3V Fail	EEPROM Failure: Remotes	Local UI Failure	-5V Fail	EEPROM Failure: Schedule	Low Battery	-15V Fail																		
EEPROM Failure: Config	Host Not Booted	+1.2V Fail																													
EEPROM Failure: Potentiometers	Host Not Responding	+3.3V Fail																													
EEPROM Failure: Remotes	Local UI Failure	-5V Fail																													
EEPROM Failure: Schedule	Low Battery	-15V Fail																													
Exciter Fault Summary (Exciter Summary)	<p>This summary alarm is triggered if any of the following Exciter related alarms occur:</p> <p><u>Controller alarms:</u></p> <table border="0"> <tr> <td>Audio Loss Shutdown</td> <td>High RF Drive</td> </tr> <tr> <td>Exciter Changeover</td> <td>Low RF Drive</td> </tr> <tr> <td>Exciter A or B Not Responding</td> <td></td> </tr> </table> <p><u>Exciter A/B alarms:</u></p> <table border="0"> <tr> <td>AES 1/ 2 Unlocked</td> <td>Low Forward Power 1/2</td> <td>Power Below Setpoint</td> </tr> <tr> <td>AM Input Loss</td> <td>No B+ Sample</td> <td>Precorrection Inhibited</td> </tr> <tr> <td>Audio Loss</td> <td>No Carrier Sync Signal</td> <td>RF Probes Uncalibrated</td> </tr> <tr> <td>B+ Sample Uncalibrated</td> <td>No External 10 MHz</td> <td>Transmitter Gain Too Low</td> </tr> <tr> <td>Carrier Sync Unlocked</td> <td>No Host Audio</td> <td>Transmitter Type Not Set</td> </tr> <tr> <td>Digital Input Loss</td> <td>No IBOC Data</td> <td>Unsigned DSP Image</td> </tr> <tr> <td>External Inhibit Active</td> <td>PLL Unlocked</td> <td>Unsigned FPGA Image</td> </tr> <tr> <td>FPGA Test Failed</td> <td></td> <td></td> </tr> </table>	Audio Loss Shutdown	High RF Drive	Exciter Changeover	Low RF Drive	Exciter A or B Not Responding		AES 1/ 2 Unlocked	Low Forward Power 1/2	Power Below Setpoint	AM Input Loss	No B+ Sample	Precorrection Inhibited	Audio Loss	No Carrier Sync Signal	RF Probes Uncalibrated	B+ Sample Uncalibrated	No External 10 MHz	Transmitter Gain Too Low	Carrier Sync Unlocked	No Host Audio	Transmitter Type Not Set	Digital Input Loss	No IBOC Data	Unsigned DSP Image	External Inhibit Active	PLL Unlocked	Unsigned FPGA Image	FPGA Test Failed		
Audio Loss Shutdown	High RF Drive																														
Exciter Changeover	Low RF Drive																														
Exciter A or B Not Responding																															
AES 1/ 2 Unlocked	Low Forward Power 1/2	Power Below Setpoint																													
AM Input Loss	No B+ Sample	Precorrection Inhibited																													
Audio Loss	No Carrier Sync Signal	RF Probes Uncalibrated																													
B+ Sample Uncalibrated	No External 10 MHz	Transmitter Gain Too Low																													
Carrier Sync Unlocked	No Host Audio	Transmitter Type Not Set																													
Digital Input Loss	No IBOC Data	Unsigned DSP Image																													
External Inhibit Active	PLL Unlocked	Unsigned FPGA Image																													
FPGA Test Failed																															

Table 4.1.6: Troubleshooting Summary Alarms

Summary Alarm Name, AUI (front panel UI)	Description and Triggering Alarms
Exgine Fault Summary (Exgine Summary)	This summary alarm is triggered if any of the following Exgine related alarms occur:  <u>Controller alarms:</u> Exgine Not Responding  <u>Exgine alarms:</u> AM/FM Mode Mismatched      FIFO Underflow      Network Misconfigured DPLL Unlocked                  Lost External 10 MHz      System Error FIFO Overflow                  Network Down
External Fault Summary (External Summary)	This summary alarm is triggered if any of the following external alarms occur:  <u>Controller alarms:</u> Combiner Interlock Open      External PDM Inhibit      Interlock Open  <u>Exciter alarms:</u> Audio Overmod Protection
GPS Sync Fault Summary (GPS Sync Summary)	This summary alarm is triggered if any of the following GPS related alarms occur:  <u>Controller alarms:</u> GPS Not Responding      GPS Receiver Not Responding      GPS Unlocked GPS PLL Unlocked      GPS Sync No 1-PPS
High Reflected Power Summary (Refl Power Summary)	This summary alarm is triggered if any of the following high reflected power related alarms occur:  <u>Controller alarms:</u> Fast SWR Shutback  <u>Exciter alarms:</u> SWR Foldback                  SWR Shutback
High Temperature Summary (High Temp Summary)	This summary alarm is triggered if any of the following temperature related alarms occur:  <u>Exciter alarms:</u> High Temperature Foldback  <u>Rack alarms:</u> High Rectifier Temperature

Table 4.1.6: Troubleshooting Summary Alarms

Summary Alarm Name, AUI (front panel UI)	Description and Triggering Alarms																																																																								
Maintenance Fault Summary (Maintenance Summary)	<p>This summary alarm is triggered if any of the following maintenance related alarms occur:</p> <p><u>Controller alarms:</u></p> <table border="0"> <tr> <td>EEPROM Failure: Config</td> <td>GPS Not Responding</td> <td>Local UI Failure</td> </tr> <tr> <td>EEPROM Failure: Potentiometers</td> <td>GPS PLL Unlocked</td> <td>Low Battery</td> </tr> <tr> <td>EEPROM Failure: Remotes</td> <td>GPS Receiver Not Responding</td> <td>Low RF Drive</td> </tr> <tr> <td>EEPROM Failure: Schedule</td> <td>GPS Sync No 1-PPS</td> <td>Rack 1 Not Responding</td> </tr> <tr> <td>EEPROM Failure: Thresholds</td> <td>GPS Unlocked</td> <td>+1.2V Fail</td> </tr> <tr> <td>Exciter Changeover</td> <td>High RF Drive</td> <td>+3.3V Fail</td> </tr> <tr> <td>Exciter A or B Not Responding</td> <td>Host Not Booted</td> <td>-5V Fail</td> </tr> <tr> <td>Exgine Not Responding</td> <td>Host Not Responding</td> <td>-15V Fail</td> </tr> </table> <p><u>Exciter alarms:</u></p> <table border="0"> <tr> <td>B+ Sample Uncalibrated</td> <td>High B+ Voltage</td> <td>No Carrier Sync Signal</td> </tr> <tr> <td>Carrier Sync Unlocked</td> <td>Low B+ Voltage</td> <td>No External 10MHz</td> </tr> <tr> <td>External Inhibit Active</td> <td>No B+ Sample</td> <td>Pre-correction Inhibited</td> </tr> </table> <p><u>Exgine alarms:</u></p> <table border="0"> <tr> <td>AM/FM Mode Mismatched</td> <td>FIFO Underflow</td> <td>Network Down</td> </tr> <tr> <td>DPLL Unlocked</td> <td>Lost External 10MHz</td> <td>Network Misconfigured</td> </tr> <tr> <td>FIFO Overflow</td> <td></td> <td></td> </tr> </table> <p><u>Module alarms:</u></p> <table border="0"> <tr> <td>External Disable Active</td> <td>High Temperature</td> <td>No Controller Comms</td> </tr> <tr> <td>Front Panel Inhibit</td> <td>Invalid Thermistor Sample</td> <td>Overmodulation</td> </tr> <tr> <td>High B+ Voltage</td> <td>Low B+ Voltage</td> <td>Residual PA Voltage</td> </tr> <tr> <td>High DC Current</td> <td>Low Fan 1/2 Speed</td> <td>RF Drive Fault</td> </tr> <tr> <td>High PA Voltage</td> <td>Low PA Voltage</td> <td>+15V Fail</td> </tr> <tr> <td>High RF Drive</td> <td>Low RF Drive</td> <td></td> </tr> </table> <p><u>Rack alarms:</u></p> <table border="0"> <tr> <td>AC Phase Loss</td> <td>High Rectifier Temp</td> <td>+5V Fail</td> </tr> <tr> <td>EEPROM Failure</td> <td>Low AC Voltage</td> <td>+30V Fail</td> </tr> <tr> <td>High Ac Voltage</td> <td>Low B+ Voltage</td> <td>+48V Fail</td> </tr> <tr> <td>High B+ Voltage</td> <td>PM 1-4 Not Responding</td> <td>-5V Fail</td> </tr> </table>	EEPROM Failure: Config	GPS Not Responding	Local UI Failure	EEPROM Failure: Potentiometers	GPS PLL Unlocked	Low Battery	EEPROM Failure: Remotes	GPS Receiver Not Responding	Low RF Drive	EEPROM Failure: Schedule	GPS Sync No 1-PPS	Rack 1 Not Responding	EEPROM Failure: Thresholds	GPS Unlocked	+1.2V Fail	Exciter Changeover	High RF Drive	+3.3V Fail	Exciter A or B Not Responding	Host Not Booted	-5V Fail	Exgine Not Responding	Host Not Responding	-15V Fail	B+ Sample Uncalibrated	High B+ Voltage	No Carrier Sync Signal	Carrier Sync Unlocked	Low B+ Voltage	No External 10MHz	External Inhibit Active	No B+ Sample	Pre-correction Inhibited	AM/FM Mode Mismatched	FIFO Underflow	Network Down	DPLL Unlocked	Lost External 10MHz	Network Misconfigured	FIFO Overflow			External Disable Active	High Temperature	No Controller Comms	Front Panel Inhibit	Invalid Thermistor Sample	Overmodulation	High B+ Voltage	Low B+ Voltage	Residual PA Voltage	High DC Current	Low Fan 1/2 Speed	RF Drive Fault	High PA Voltage	Low PA Voltage	+15V Fail	High RF Drive	Low RF Drive		AC Phase Loss	High Rectifier Temp	+5V Fail	EEPROM Failure	Low AC Voltage	+30V Fail	High Ac Voltage	Low B+ Voltage	+48V Fail	High B+ Voltage	PM 1-4 Not Responding	-5V Fail
EEPROM Failure: Config	GPS Not Responding	Local UI Failure																																																																							
EEPROM Failure: Potentiometers	GPS PLL Unlocked	Low Battery																																																																							
EEPROM Failure: Remotes	GPS Receiver Not Responding	Low RF Drive																																																																							
EEPROM Failure: Schedule	GPS Sync No 1-PPS	Rack 1 Not Responding																																																																							
EEPROM Failure: Thresholds	GPS Unlocked	+1.2V Fail																																																																							
Exciter Changeover	High RF Drive	+3.3V Fail																																																																							
Exciter A or B Not Responding	Host Not Booted	-5V Fail																																																																							
Exgine Not Responding	Host Not Responding	-15V Fail																																																																							
B+ Sample Uncalibrated	High B+ Voltage	No Carrier Sync Signal																																																																							
Carrier Sync Unlocked	Low B+ Voltage	No External 10MHz																																																																							
External Inhibit Active	No B+ Sample	Pre-correction Inhibited																																																																							
AM/FM Mode Mismatched	FIFO Underflow	Network Down																																																																							
DPLL Unlocked	Lost External 10MHz	Network Misconfigured																																																																							
FIFO Overflow																																																																									
External Disable Active	High Temperature	No Controller Comms																																																																							
Front Panel Inhibit	Invalid Thermistor Sample	Overmodulation																																																																							
High B+ Voltage	Low B+ Voltage	Residual PA Voltage																																																																							
High DC Current	Low Fan 1/2 Speed	RF Drive Fault																																																																							
High PA Voltage	Low PA Voltage	+15V Fail																																																																							
High RF Drive	Low RF Drive																																																																								
AC Phase Loss	High Rectifier Temp	+5V Fail																																																																							
EEPROM Failure	Low AC Voltage	+30V Fail																																																																							
High Ac Voltage	Low B+ Voltage	+48V Fail																																																																							
High B+ Voltage	PM 1-4 Not Responding	-5V Fail																																																																							



Table 4.1.6: Troubleshooting Summary Alarms

Summary Alarm Name, AUI (front panel UI)	Description and Triggering Alarms
Off Air Summary (Off Air Summary)	This summary alarm is triggered if any of the following off-air related alarms occur:  <u>Controller alarms:</u> Arc Shutback                      Combiner Interlock Open    Fast SWR Shutback Audio Loss Shutdown              External PDM Inhibit        Interlock Open  <u>Exciter alarms:</u> FPGA Test Failed                      RF Probes Uncalibrated    Transmitter Type Not Set Over-Current Shutback              SWR Shutback                Unsigned DSP Image PLL Unlocked                              Transmitter Gain Too Low    Unsigned FPGA Image  <u>Rack alarms:</u> Arc Detector 1                              High B+ Shutback              Low B+ Shutdown
Output Network Fault Summary (O/P Network Summary)	This summary alarm is triggered if any of the following output network related alarms occur:  <u>Controller alarms:</u> Arc Shutback                              Fast SWR Shutback  <u>Exciter alarms:</u> Cutback                                      Over-Current Shutback        SWR Shutback High Forward Foldback                SWR Foldback  <u>Rack alarms:</u> Arc Detector 1
Power Module Fault Summary (PM Summary)	This summary alarm is triggered if any of the following power module related alarms occur:  <u>Module alarms:</u> EEPROM Failure                      High RF Drive                      Low RF Drive External Disable Active              High Temperature                No Controller Comms Front Panel Inhibit                    Invalid Thermistor Sample        Overmodulation High B+ Voltage                        Low B+ Voltage                    Residual PA Voltage Present High DC Current                        Low Fan 1/2 Speed                RF Drive Fault High PA Voltage                        Low PA Voltage                    +15V Fail  <u>Rack alarms:</u> PM 1-4 Not Responding

Table 4.1.6: Troubleshooting Summary Alarms

Summary Alarm Name, AUI (front panel UI)	Description and Triggering Alarms
Power Supply Fault Summary (PS Summary)	This summary alarm is triggered if any of the following power supply related alarms occur:  <u>Exciter alarms:</u> High B+ Voltage            High DC Curr Foldback            Low B+ Voltage  <u>Rack alarms:</u> AC Phase Loss            High Rectifier Temp            +15V Fail High AC Voltage            Low AC Voltage            +30V Fail High B+ Shutback            Low B+ Shutdown            +48V Fail High B+ Voltage            +5V Fail            -15V Fail High DC Curr Foldback
Rack Fault Summary (Rack Summary)	This summary alarm is triggered if any of the following rack related alarms occur:  <u>Controller alarms:</u> Rack 1 Not Responding  <u>Rack alarms:</u> EEPROM Failure
Reduced Power Summary (Power Low Summary)	This summary alarm is triggered if any of the following reduced power related alarms occur:  <u>Exciter alarms:</u> Audio Overmod Protection            High Forward Foldback            Power Below Setpoint Cutback            High Temp Foldback            SWR Foldback High DC Current Foldback            Low Forward Power 1/2

Table 4.1.7: Module Replacement Procedures

Module	Replacement Procedure
RF Power Module	See <a href="#">page 4.1.52</a>
Power Amplifier MOSFET	See <a href="#">page 4.1.61</a>
Modulator MOSFET	See <a href="#">page 4.1.63</a>
Control/Interface PWB	See <a href="#">page 4.1.65</a>
SCR Rectifier Assembly	See <a href="#">page 4.1.67</a>
Digital AM Exciter PWB	See <a href="#">page 4.1.69</a>
Exgine PWB	See <a href="#">page 4.1.74</a>
GPS Sync PWB	See <a href="#">page 4.1.74</a>
Rack Interface PWB	See <a href="#">page 4.1.75</a>
Power Module Interface PWB	See <a href="#">page 4.1.77</a>
Gas Discharge PWB and Relays	See <a href="#">page 4.1.79</a>
Fan Tray	See <a href="#">page 4.1.81</a>
Fan Tray Cooling Fan	See <a href="#">page 4.1.82</a>
RF Voltage and Current Sample PWB	See <a href="#">page 4.1.83</a>
Directional Coupler	See <a href="#">page 4.1.87</a>
Arc Detector UV Sensor	See <a href="#">page 4.1.89</a>
+15 V or +48 V Power Supply	See <a href="#">page 4.1.92</a>
Graphic User Interface (GUI) and UI Interface PWB	See <a href="#">page 4.1.94</a>

---

## Accessing the Inside of the Transmitter

See Figure 4.1.4 on page 4.1.45.

### Front Access

The front of the NX10 has a hinged door that provides access to the control/exciter panel, which contains the control/interface PWB (A4), digital AM exciter PWBs (A5 and optional A6), Exgine PWB (A7, optional) and GPS sync PWB (A8, optional). You can also access RF power modules 1 through 4 (A12 through A15) and fan tray assemblies (A16 through A19).

Removing the 16 M5 screws that secure the hinged control/exciter panel allows access to the directional coupler assembly (A23).

Removing the 16 M5 screws that secure the lower, front panel allows access to the power transformer (T1). It should not be necessary to access the power transformer, but when it is necessary, use extreme caution as high voltage is present behind the panel when ac power is being applied.

**WARNING! WHEN AC POWER IS ENABLED (ON), DANGEROUS VOLTAGES THAT CAN CAUSE INJURY OR DEATH ARE PRESENT BEHIND THE LOWER, FRONT PANEL. NAUTEL RECOMMENDS THAT ONLY TRAINED PERSONNEL BE ALLOWED ACCESS TO THIS AREA.**

**DISCONNECT AND LOCK OUT AC POWER BEFORE WORKING IN AREAS WHERE DANGEROUS VOLTAGES MAY BE PRESENT TO ENSURE THE SAFETY OF PERSONNEL.**

### Rear Access

The rear of the NX10 has a hinged door that - for safety purposes - is also secured with 24 screws. Removing these screws and opening the door provides access to the rectifier assembly (A1), rack interface PWB (A9), power module interface PWBs (A10 and A11), RF voltage and current sample PWB (A20), arc detector assembly (A24), +15 V power supply (U1) and +48 V power supply (U2).

**WARNING! WHEN AC POWER IS ENABLED (ON), DANGEROUS VOLTAGES THAT CAN CAUSE INJURY OR DEATH ARE PRESENT BEHIND THE REAR PANEL. NAUTEL RECOMMENDS THAT ONLY TRAINED PERSONNEL BE ALLOWED ACCESS TO THIS AREA.**

**DISCONNECT AND LOCK OUT AC POWER BEFORE WORKING IN AREAS WHERE DANGEROUS VOLTAGES MAY BE PRESENT TO ENSURE THE SAFETY OF PERSONNEL.**

Figure 4.1.4: Front and Rear Access

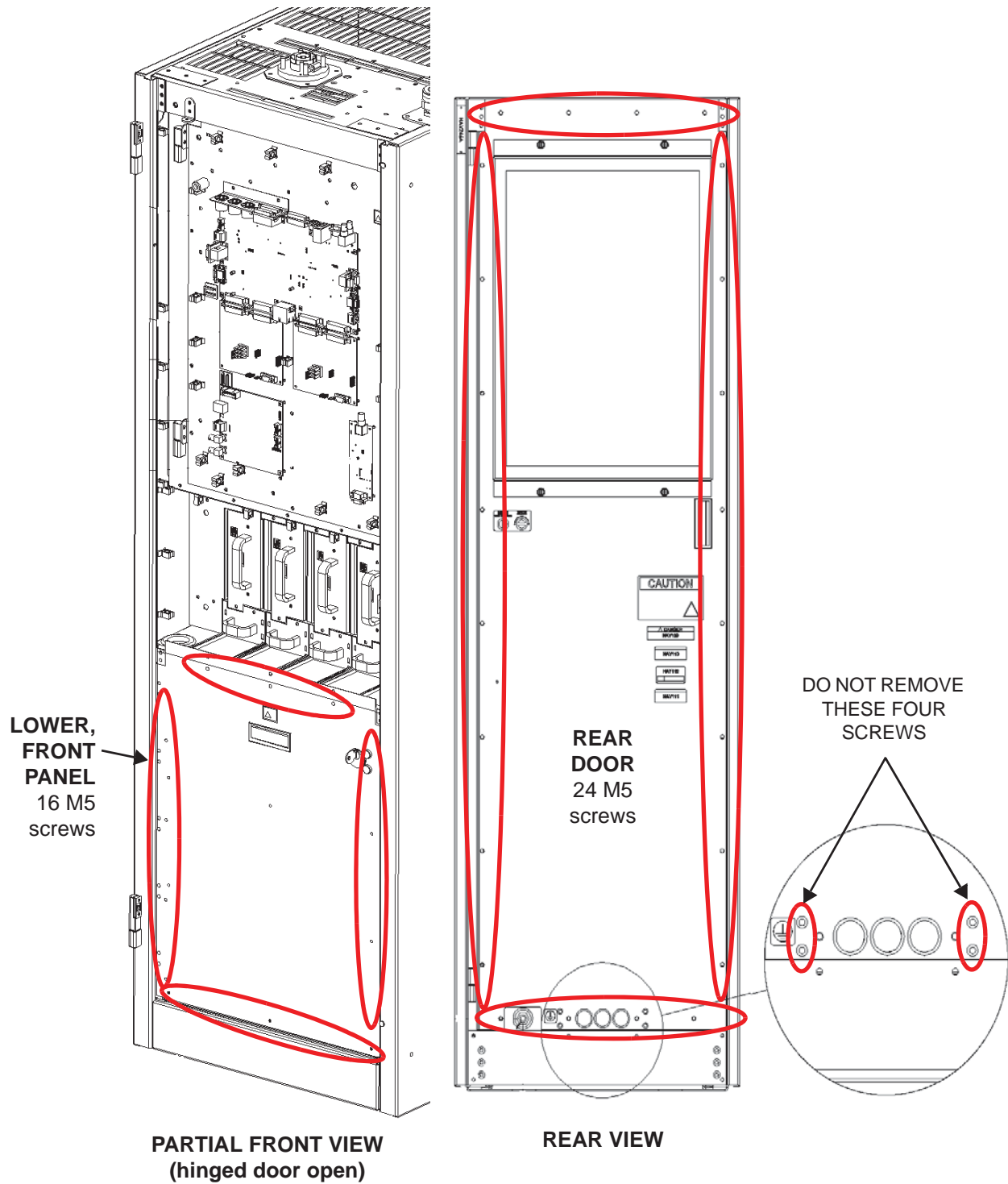

---

## Troubleshooting Tips

### Controller: External PDM Inhibit

A Controller: External PDM Inhibit alarm indicates that an external PDM inhibit command is present. The alarm could be caused by a short circuit in the external wiring path to the control/interface PWB or a fault in the switching circuitry on the control/interface PWB. Troubleshoot as follows:

The external PDM inhibit is wired to the control/interface PWB.

1. Gain access to the control/interface PWB (A4) (see [Figure 4.1.12 on page 4.1.66](#)) by opening the transmitter's front door. The door is not latched and just swings open to the left.
2. Connect a digital multimeter (set to measure dc) between J6A-12 of the control/interface PWB and ground.
  - ❖ If 15 V is present on J6A-12, there is no external PDM inhibit command. Suspect the control/interface PWB and if necessary, replace it (see "[Control/Interface PWB Removal/Replacement](#)" on page 4.1.65).
  - ❖ If 0 V is present on J6A-12, there is a valid external PDM inhibit command. Check the external PDM inhibit circuitry to determine the cause.

### Controller: Interlock Open

A Controller: Interlock Open alarm indicates an external interlock is open. The transmitter's RF output will be inhibited.

The external interlock input is wired to the control/interface PWB by the end user and triggered by the conditions that they set (e.g., the state of the door to the transmitter room).

1. Gain access to the control/interface PWB (A4) (see [Figure 4.1.12 on page 4.1.66](#)) by opening the transmitter's front door. The door is not latched and just swings open to the left.
2. Connect a digital multimeter (set to measure dc) between J6A-20 of the control/interface PWB and ground.
  - ❖ If 0 V is present on J6A-20, the external interlock circuit is intact and the probable cause of the alarm is a defective monitoring circuit. Suspect the control/interface PWB and if necessary, replace it (see "[Control/Interface PWB Removal/Replacement](#)" on page 4.1.65).
  - ❖ If 15 V is present, the external interlock circuit is open (normally caused by an open interlock switch). Check the external system interlock circuitry to determine the cause.

## RF Module Faults

There are many alarms on the front panel UI or remote AUI, prefixed by the text PM, that indicate faults related to one or more of the four RF power modules in the transmitter. The number that appears after Module (1-4) identifies the position of the affected module. Numbers correspond to modules in a left to right sequence, as viewed from the front of the transmitter.

1. Check the forward power reading on the front panel UI or remote AUI. If it is less than the preset level, one or more RF power modules are defective. Proceed to [“RF Power Module Fault Validation”](#) on page 4.1.49.
2. If the forward power reading in [Step 1](#) is normal, go to the front panel UI’s Alarms screen or click the remote AUI’s Status button to check for other alarms that may have triggered the RF power module alarm.
3. From the remote AUI’s Meter List View page (see [Figure 4.1.5](#)), click the **i** (information) button next to the Modules - Rack 1 folder in the Transmitter Layout section to view the status screen for all RF power modules (see [Figure 4.1.6](#) on page 4.1.48) or click the left-hand drop-arrow to expand the Modules folder to allow clicking on the **i** button for an individual Module (PM) (see [Figure 4.1.7](#) on page 4.1.48). You can also use the front panel UI’s View Status -> View Meters -> Module screen to view meters sorted by meter name, by pressing the checkmark button, or by RF power module (PM), by pressing the right-hand arrow button. These screens display critical parameters for RF power modules. As an aid in troubleshooting, compare parameters to isolate possible module faults.

Figure 4.1.5: AUI - Meter List View page

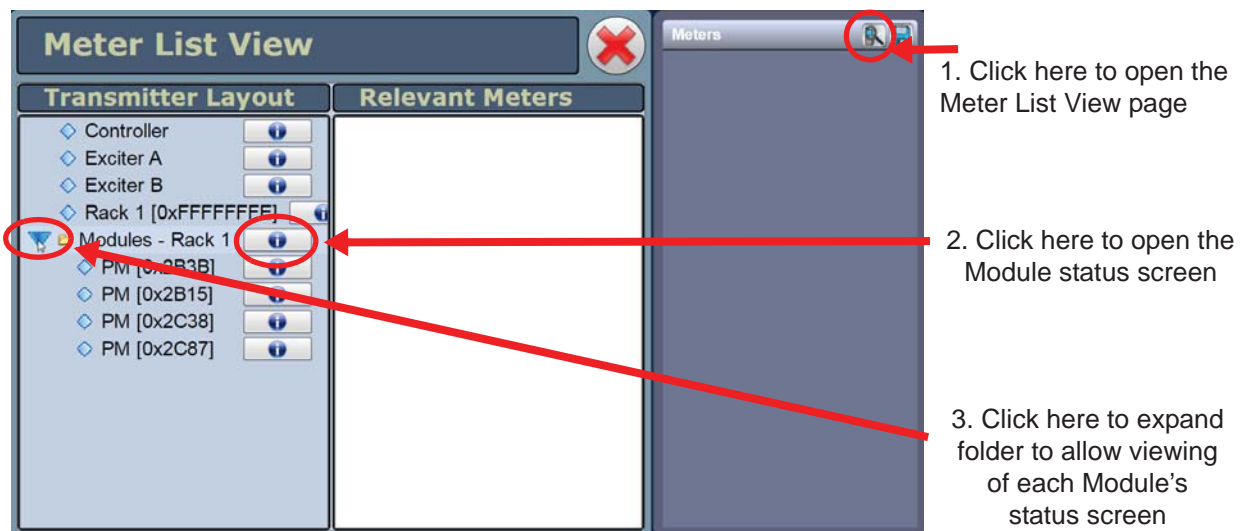
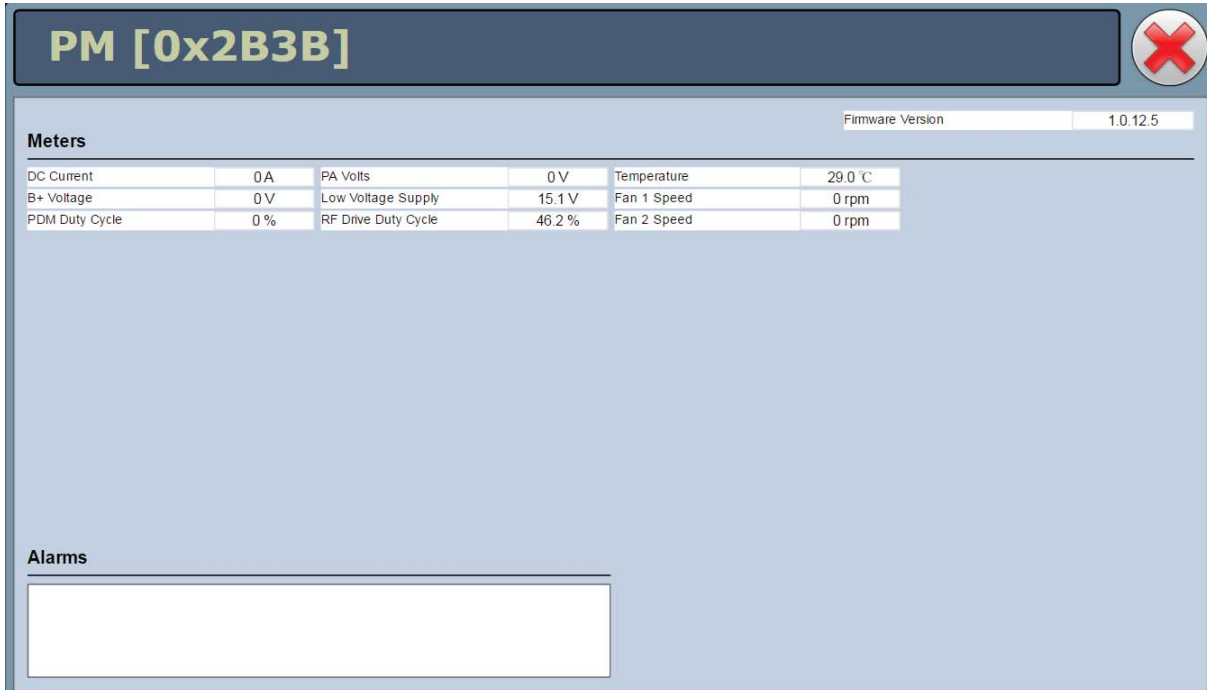

Figure 4.1.6: RF Module Status Screen (all modules)



Figure 4.1.7: RF Module Status Screen (individual module)





---

### RF Power Module Fault Validation

Each RF power module has a multi-colour LED on its front panel, which can help in identifying a fault and allowing you to determine whether remedial action is required now or later.

Identify and isolate a defective RF power module, and verify the nature of the defect by checking the LEDs on the RF power modules' front panels. Note which RF power module is not operating normally and producing RF power (i.e., LED is not solid green). Record which RF power module(s) is/are displaying an alarm and the state of its/their LED (see below).

- ❖ solid green: module is producing RF with no alarms
- ❖ flashing amber and off: module is RF off
- ❖ solid red: module has a non-latching alarm, and is not producing RF
- ❖ flashing red, then green: module is producing RF, but has an alarm
- ❖ long red, short amber: module has a latching alarm, and is not producing RF
- ❖ long red, short off: module has no valid serial number
- ❖ short red, long off: module has no valid serial address on the internal bus
- ❖ long amber, short green: module is producing RF, but is receiving no serial communication from the rack interface
- ❖ long amber, short red: module is not producing RF and is receiving no serial communication from the rack interface

Except in the case of a High PA Volts or Residual PA Volts alarm, attempt to reset an RF power module by disconnecting and reconnecting the RJ45 plug in the front of the module. If you cannot reset the front panel LED alarm, see ["RF Power Module Troubleshooting"](#).

### RF Power Module Troubleshooting

Refer to ["Removing and Reinstalling RF Power Modules"](#) on page 4.1.52 for removal and installation instructions and then refer to ["Troubleshooting RF Power Modules"](#) on page 4.1.57 for detailed troubleshooting information.

**NOTE:** A defective RF power module can be removed for repair without turning off the transmitter, as described in ["Removing an RF Power Module"](#) on page 4.1.52. The transmitter can be operated at a reduced output power level with an RF power module removed.

**WARNING! FAILURE TO FOLLOW THE RF POWER MODULE REMOVAL INSTRUCTIONS MAY RESULT IN INJURY TO THE OPERATOR AND SERIOUS PHYSICAL DAMAGE TO THE RF POWER MODULE AND TRANSMITTER.**

---

## RF Module #: Low B+ Voltage

A Module # Low B+ Voltage alarm is triggered when the B+ voltage is less than 75% of its nominal level.

1. If all RF power modules are reporting this alarm, it is very likely there is also a Rack #: Low B+ Voltage alarm. If so, the fault is not likely associated with an RF power module; proceed to ["Rack #: Low B+ Voltage Alarm"](#) for further troubleshooting information. If not, proceed to [Step 2](#).
2. Check and, if necessary, replace the fuse on the power module interface PWB for the affected RF power module. Each power module interface PWB serves two RF power modules and therefore has two B+ fuses (F1 and F2). Refer to Figure MD-2 in the Mechanical Drawings section of this manual to locate the associated power module interface PWB and then refer to Figure MD-9 to locate fuse F1 or F2. If the alarm persists, continue to [Step 3](#).
3. Check and, if necessary, replace the affected RF power module. See ["Troubleshooting RF Power Modules"](#) on page 4.1.57.

## Rack #: Low B+ Voltage Alarm

A Rack #: Low B+ Voltage alarm is triggered when the B+ voltage is at least 25% below its expected level. Recovery from this alarm is automatic when the B+ voltage rises to an acceptable level.

**NOTE:** An NX10 transmitter has only one rack (or cabinet) and will only display Rack 1.

If the transmitter does not automatically recover from this alarm, the low B+ voltage is normally caused by low ac input voltage, improper primary tap settings on the power transformer, or a faulty rectifier assembly. Troubleshoot a Rack #: Low B+ alarm as follows.

**WARNING! LETHAL VOLTAGES EXIST IN THE POWER SUPPLY COMPARTMENT OF THE TRANSMITTER. USE EXTREME CAUTION IN THIS AREA.**

1. Check the B+ voltage on the transmitter's AUI. If it is less than 75% of desired, the ac power source voltage or power transformer tap selection is suspect.
2. Check the ac sample voltage. If less than 302 V, continue to [Step 3](#). If not, go to [Step 4](#).
3. Measure the ac input voltage and verify the power transformer is tapped as shown in Section 2.4 of the NX10 Installation Manual. If necessary, turn off the transmitter, lock out the ac input voltage and retap the power transformer for the next lower voltage.
4. If the transformer taps are correct, the rectifier assembly may be defective or there may be a fault with the monitoring circuit. Contact Nautel for troubleshooting information.

## Rack #: Low AC

A Rack #: Low AC alarm is triggered when the ac input voltage is less than 256 V. Recovery from this alarm is automatic when the ac voltage rises to an acceptable level.

**NOTE:** An NX10 transmitter has only one rack (or cabinet) and will only display Rack 1.

If the transmitter does not automatically recover from this alarm, the low ac voltage is normally caused by low ac mains voltage or improper primary tap settings on the power transformer. Troubleshoot a Rack #: Low AC alarm as follows.

**WARNING! LETHAL VOLTAGES EXIST IN THE POWER SUPPLY COMPARTMENT OF THE TRANSMITTER. USE EXTREME CAUTION IN THIS AREA.**

1. Measure the ac input voltage and verify the power transformer is tapped as shown in Section 2.4 of the NX10 Installation Manual. If necessary, turn off the transmitter, lock out the ac input voltage and retap the power transformer for the next lower voltage.
2. If the transformer taps are correct, the monitoring circuit may be defective. Contact Nautel for troubleshooting information.

---

## Removing and Reinstalling RF Power Modules

### Removing an RF Power Module

1. Confirm the location of the RF power module that is being removed. Note the alarm text includes a Module serial address that is also identified on the front panel of each RF power module. See [Figure 4.1.8 on page 4.1.53](#) to determine the location for a given RF power module [1 (A12) through 4 (A15)].
2. If possible, turn off the transmitter before removing an RF power module. If you need to remove a module while "on air", disable the RF power module to be removed using the front panel UI or the remote AUI.
  - ❖ Front Panel UI: From the Main Menu, go to the System Settings -> PM Inhibit screen (see [Figure 4.1.9 on page 4.1.54](#)). Use the up and down buttons to move the cursor to the desired RF power module (1 through 4) and then press the right button to enable editing. Use the up and down buttons to select Enable or Disable. Press the accept (checkmark) button to save the change. Press cancel (X) to discard changes and return to the previous menu.
  - ❖ Remote AUI: From the Meters page, click on the Modules - Rack 1 information (i) button. The Power Module status screen (see [Figure 4.1.9 on page 4.1.54](#)) should appear. Click on the associated RF power module's Front Panel Inhibit icon. The icon colour should change from green to red, indicating the RF power module is disabled.
3. After the RF power module is disabled, you should hear a relay in the back of the cabinet drop out (de-energize). If you do not hear the relay de-energize (click), **DO NOT CONTINUE** to [Step 4](#). Try re-enabling and disabling a few times while trying to hear the relay de-energize. If you do not hear the sound, **DO NOT** remove the RF power module while the transmitter is on-air. Turn RF Off, remove the RF power module and replace the relay before turning RF On (see ["Gas Discharge PWB and Relay Replacement" on page 4.1.79](#)).
4. Disconnect the RJ45 cable from the front of the RF power module.

**WARNING! FAILURE TO FOLLOW THE RF POWER MODULE REMOVAL INSTRUCTIONS MAY RESULT IN INJURY TO THE OPERATOR AND SERIOUS PHYSICAL DAMAGE TO THE RF POWER MODULE AND TRANSMITTER.**

5. Remove both mounting screws from the RF power module's front panel.
6. Grasp the handle on the front of the RF power module and carefully pull the RF power module out of the transmitter.

Figure 4.1.8: RF Power Module Locations

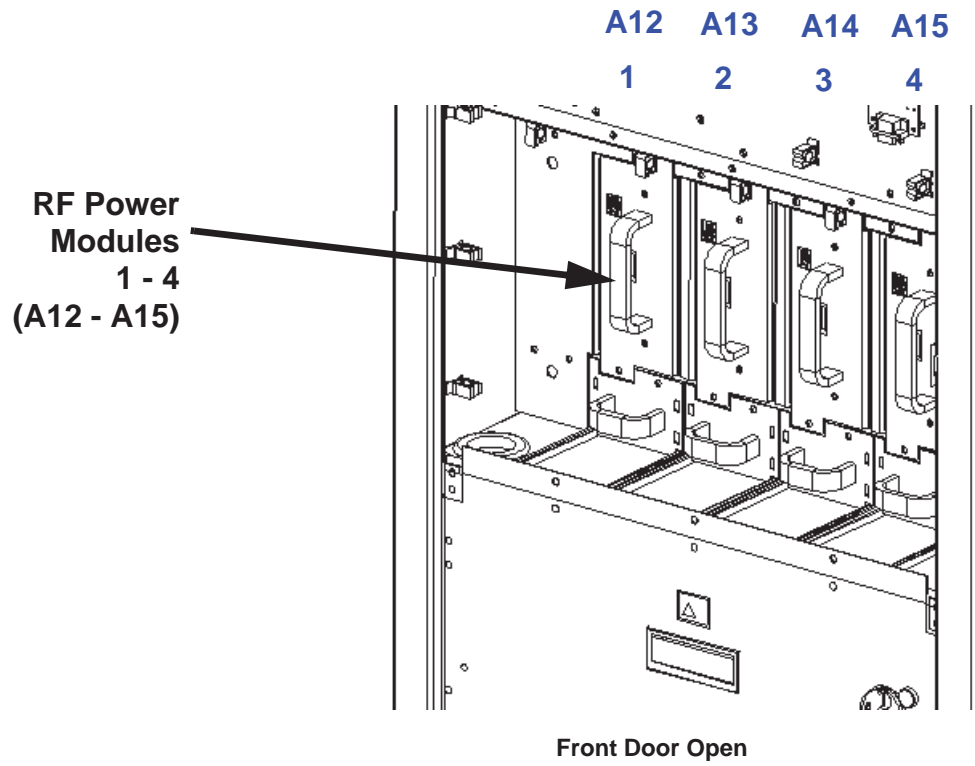
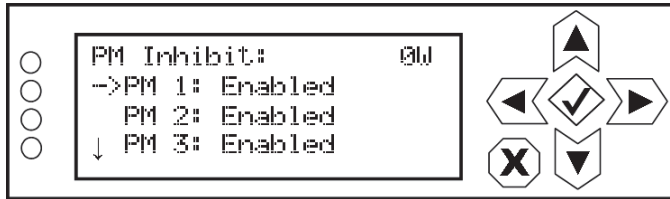

Figure 4.1.9: Disabling/Enabling an RF Power Module

Front Panel UI: Main Menu -> System Settings -> PM Inhibit



Remote AUI: Meters Page -> Rack information (i) button

Green indicates enabled. Click to disable (will turn red);  
click again to re-enable (will turn green)

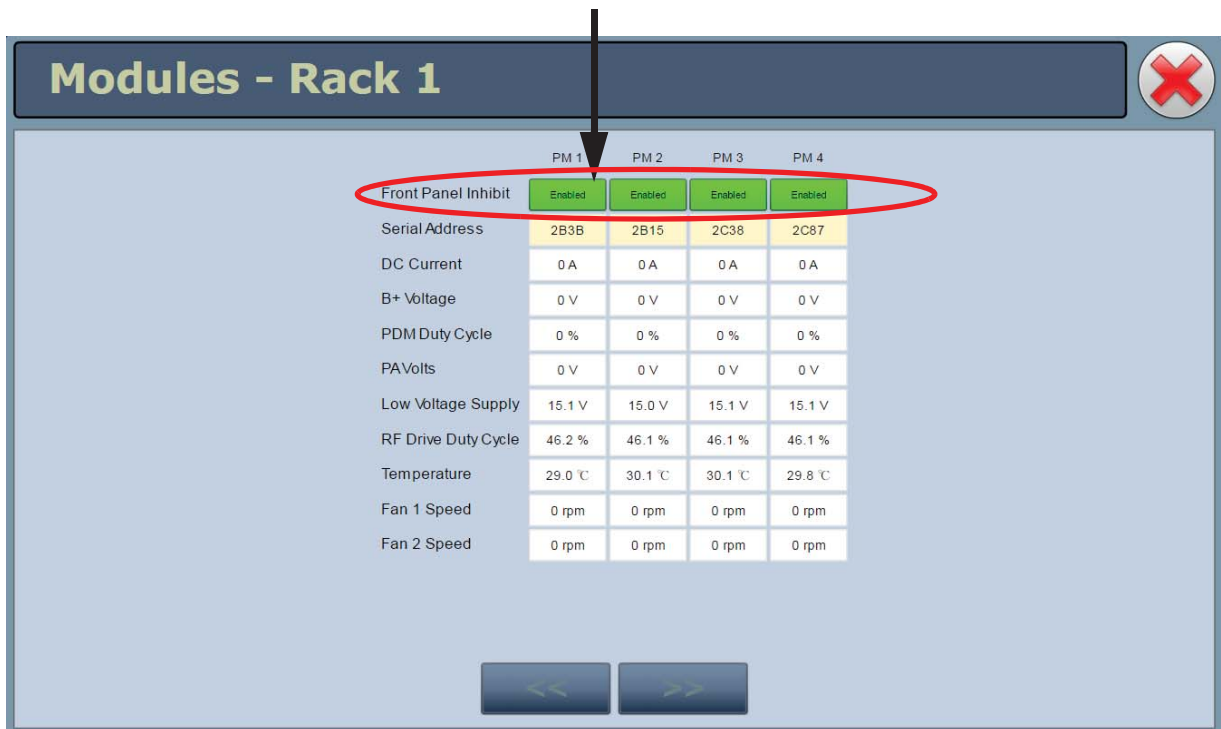

---

## Installing an RF Power Module

**NOTE:** To ensure the transmitter recognizes RF power modules being installed, modules must be programmed with software version equivalent to NX SW 4.4 or newer.

1. If possible, turn off the transmitter before installing an RF power module. Grasp the handle on the front of the RF power module and insert it into the transmitter.
2. Carefully push the RF power module into place so that its card-edge connector mates with the transmitter. Verify the RF power module is fully inserted by ensuring the faceplate of the RF power module is touching the transmitter chassis that it mates with.
3. Install both mounting screws in the RF power module's front panel.
4. Connect the RJ45 cable to the front of the RF power module.
5. If the RF power module was disabled through a user interface, enable it as follows:
  - ❖ Front Panel UI: From the Main Menu, go to the System Settings -> PM Inhibit screen (see [Figure 4.1.9 on page 4.1.54](#)). Use the up and down buttons to move the cursor to the desired RF power module (1 through 4) and then press the right button to enable editing. Use the up and down buttons to select Enable. Press the accept (checkmark) button to save the change. Press cancel (X) to discard changes and return to the previous menu.
  - ❖ Remote AUI: From the Meters page, click on the Modules - Rack 1 information (i) button. The Power Module status screen (see [Figure 4.1.9 on page 4.1.54](#)) should appear. Click on the associated RF power module's Front Panel Inhibit icon. The icon colour should change from red to green, indicating the RF power module is enabled.

You should hear a relay in the back of the transmitter pick up (energize).

6. Upgrade the RF power module's software using the front panel UI's Updating Firmware screen or the remote AUI's Upgrade Software page under the appropriate System Settings menu, by running an upgrade using the existing .tgz file already installed on the transmitter. See the NX10 Operations and Maintenance Manual for detailed instructions.

---

## Optimizing RF Power Module Performance

When swapping damaged RF power modules with new RF power modules, it is possible that spurs of the fundamental PDM frequency ( $f_c \pm 155$  kHz) may appear at the output of the transmitter. If these spurs violate the emissions limits of the region of installation, the problem may be corrected by initiating the PDM minimization routine, as follows:

**CAUTION!** Running the PDM minimization routine will disable the exciter's SWR protection. For this reason, you should only run this routine when the transmitter is connected to a suitable rated 50 ohm test load.

1. Turn off (RF Off) the transmitter and connect its RF output to a suitably rated 50-ohm test load.
2. Using the front panel UI or the remote AUI, set the following items as instructed:
  - ❖ Overall Mode = Analog AM
  - ❖ Output Power = rated power
  - ❖ AM Source = Unused
3. Set the transmitter to its RF On state.
4. Using the front panel UI or the remote AUI, navigate to the PDM minimization routine:
  - ❖ Front Panel UI: From the Main Menu, go to the Factory Settings -> PDM Settings -> PDM Minimization screen. Press the accept (checkmark) button to start the routine.
  - ❖ Remote AUI: From the Factory Settings -> PDM Settings page, click on the Start button next to Minimization Routine.

The PDM minimization routine requires approximately 30 minutes to complete.



## Troubleshooting RF Power Modules

### Maintenance Philosophy

Recommended troubleshooting procedures for RF power modules are limited to “go” or “no-go” resistance or diode measurements on the module’s power semi-conductors and replacement procedures for these devices.

### Special Tools and Test Equipment

The following test equipment and cables are required to troubleshoot an RF power module.

- A digital multimeter with resistance and diode settings.
- A torque screwdriver with a torque range of 0 to 2.3 N-m (0 - 20 in-lbs). Required for installing MOSFET attaching hardware.
- A soldering iron and desoldering tool.
- An NX10 spares kit (contains replacement semi-conductors).

### Electrostatic Precautions

The RF power module contains semiconductor devices that are susceptible to damage from electrostatic discharge. Follow the electrostatic precautions in “[Electrostatic Protection](#)” on [page 4.1.3](#) at all times.

### Preparation for Troubleshooting

1. Follow the procedure in “[Removing an RF Power Module](#)” on [page 4.1.52](#) to remove the RF power module from the transmitter.
2. Place the RF power module on a suitable work surface.
3. Perform the resistance measurements on the modulator and power amplifier MOSFETs as described in “[Resistance Measurements](#)” on [page 4.1.58](#).
4. Perform the diode checks on the protection and free-wheel diodes as described in “[Protection Diode Checks](#)” on [page 4.1.58](#) and “[Protection Diode Checks](#)” on [page 4.1.58](#).
5. If the measurements in [Step 3](#) and [Step 4](#) are satisfactory, but the RF power module continues to display alarms when installed in the transmitter, replace the RF power module.

---

## Resistance Measurements

Complete the following resistance measurements for each suspect RF power module. See [Figure 4.1.10 on page 4.1.60](#) to identify the power MOSFETs on the RF power module.

1. Remove fuse F1 from its holder and measure its resistance using a digital multimeter. A blown fuse will measure an open circuit. If the fuse is OK, return it to its holder.
2. For each power amplifier MOSFET (Q7 through Q10) and each modulator MOSFET (Q11, Q12 and Q13), use a digital multimeter to make the following resistance measurements. Note that Q7 through Q10 have screw-head terminals and Q11 through Q13 have solder pads (see [Figure 4.1.10 on page 4.1.60](#)):
  - ❖ Check for 1,000  $\Omega$  between the gate and source.
  - ❖ Check for an open circuit between the gate and drain.
3. If either measurement in [Step 2](#) is not satisfactory, replace the affected power amplifier MOSFET (see “[Power Amplifier FET Replacement](#)” on [page 4.1.61](#)) or modulator MOSFET (see “[Modulator FET or Free-Wheel Diode Replacement](#)” on [page 4.1.63](#)), as applicable, or replace the RF power module.

## Protection Diode Checks

Complete the following protection diode checks for each suspect RF power module. See [Figure 4.1.10 on page 4.1.60](#) to identify the protection diode on the RF power module.

1. Use a digital multimeter (on its diode setting) to check protection diode CR9, noting the anode (A) and cathode (K) markings (see [Figure 4.1.10 on page 4.1.60](#)):
  - ❖ Check for a voltage of between 0.5 and 0.8 V with multimeter test leads in the forward bias orientation (+ on anode, - on cathode).
  - ❖ Check for an open circuit with multimeter test leads in the reverse bias orientation (- on anode, + on cathode).
2. If the diode is not satisfactory, replace it by desoldering its surface-mount leads and case from the PWB. Locate a replacement diode (Nautel Part # QM72) in the spares kit, if purchased, and solder it to the PWB, noting correct orientation.

## Free-Wheel Diode Checks

Complete the following free-wheel diode checks for each suspect RF power module. See [Figure 4.1.10 on page 4.1.60](#) to identify the free-wheel diodes on the RF power module.

1. Use a digital multimeter (on its diode setting) to check free-wheel diodes CR19 through CR21, noting the anode (A) and cathode (K) markings (see [Figure 4.1.10 on page 4.1.60](#)):
  - ❖ Check for a voltage of between 0.4 and 0.8 V with multimeter test leads in the forward bias orientation (+ on anode, - on cathode).
  - ❖ Check for an open circuit with multimeter test leads in the reverse bias orientation (- on anode, + on cathode).
2. If a diode is not satisfactory, replace it as detailed in [“Modulator FET or Free-Wheel Diode Replacement” on page 4.1.63](#).

Figure 4.1.10: RF Power Module MOSFET and Diode Locations

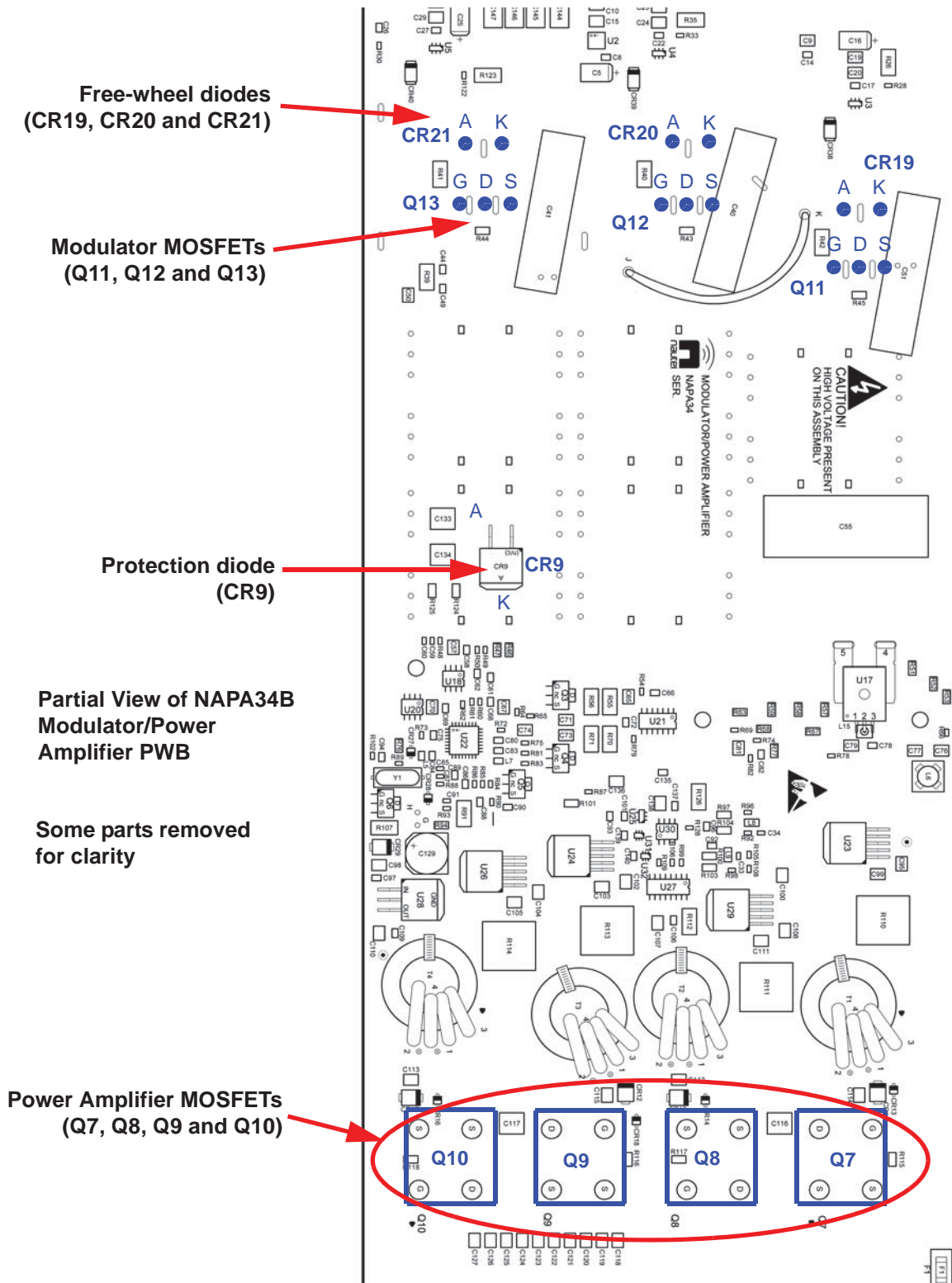

## Power Amplifier FET Replacement

See [Figure 4.1.11](#) on [page 4.1.62](#).

1. Remove five M3 screws that secure the modulator/power amplifier PWB to the chassis.
2. Remove 16 M4 screws (four for each MOSFET) that secure the PWB to the MOSFETs.
3. Swing the PWB away from the chassis and remove two M4 screws that secure the defective MOSFET to the chassis. If necessary, remove the screw securing the thermistor wire to the heatsink.
4. Discard the defective MOSFET and its associated thermal pad (between MOSFET and heatsink).
5. Ensure the surface of the heatsink is clean and free of debris.
6. Obtain a replacement MOSFET (Nautel Part # QR68) and a new thermal pad (Nautel Part # HAK55) from the spares kit, if purchased, and install them on the RF power module chassis using the two M4 screws removed in step 3. Torque hardware to 12 in-lbs (1.3 N-m).
7. Replace any other defective MOSFETs and then re-install the PWB to the chassis by reversing the instructions in steps 1 through 3. Torque the 16 MOSFET screws (four for each MOSFET) to 10 in-lbs (1.1 N-m).
8. Return the power module to service (see [“Installing an RF Power Module”](#) on [page 4.1.55](#)).

Figure 4.1.11: Power Amplifier FET Replacement

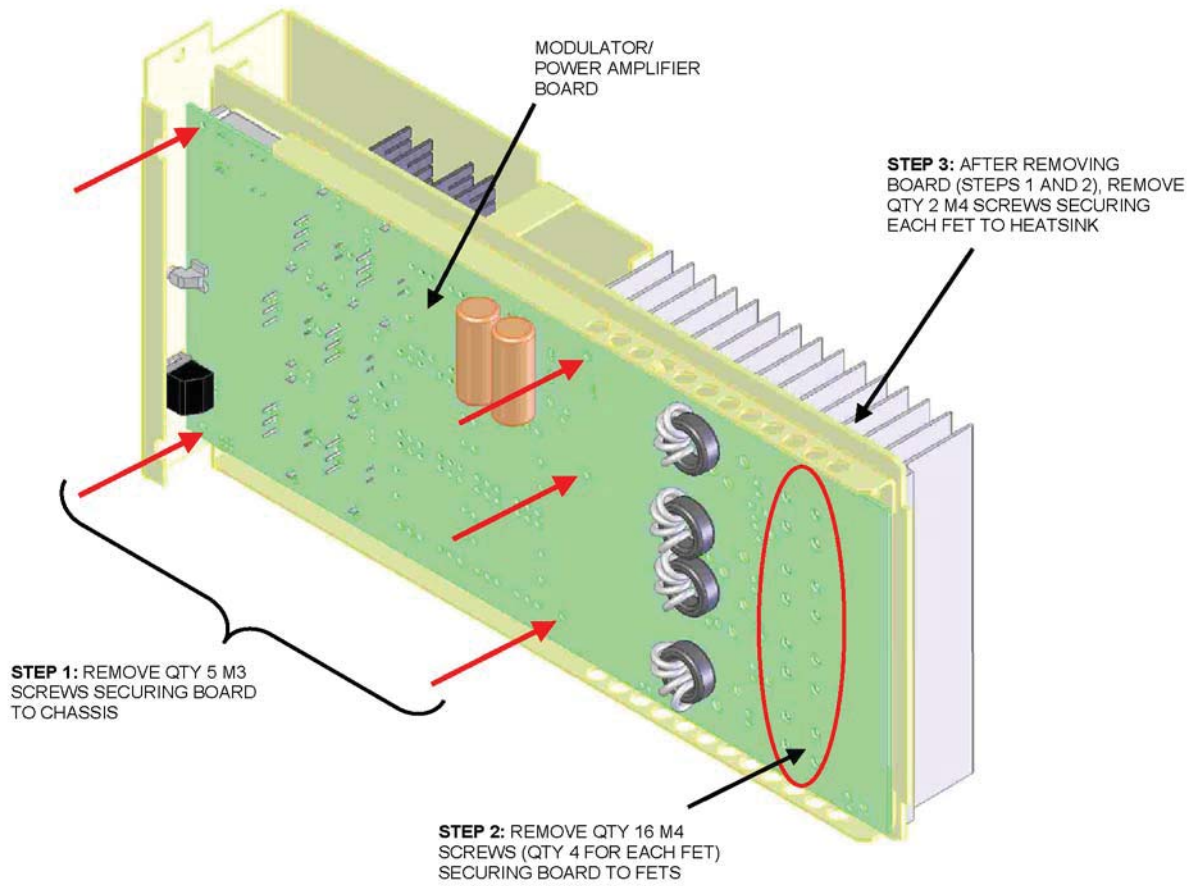

---

## Modulator FET or Free-Wheel Diode Replacement

1. Remove five M3 screws that secure the modulator/power amplifier PWB to the chassis.
2. Remove 16 M4 screws (four for each device) that secure the PWB to the devices.
3. Swing the PWB away from the chassis. If necessary, remove the screw securing the thermistor wire to the heatsink.
4. Desolder the connections that secure the defective device (modulator FET or free-wheel diode) to the PWB (see [Figure 4.1.10 on page 4.1.60](#)):
  - ❖ For modulator FETs (Q11, Q12, Q13), desolder the gate (G), drain (D) and source (S) connections.
  - ❖ For free-wheel diodes (CR19, CR20, CR21), desolder the anode (A) and cathode (K) connections.

Also desolder the two connections that secure the defective device's heatsink to the PWB. Remove the heat sink and the device from the PWB.

5. Remove the heatsink clip that holds the device on its heat sink. Remove and discard the defective device.

**CAUTION!** The heat sinks of modulator devices are coated with a film of thermal compound. Use care to ensure the film does not become contaminated with foreign particles.

When installing a replacement device, visually inspect the mating surfaces of the device and its heat sink. Ensure the heat sink surface is coated with a thin film of thermal compound. Ensure foreign particles that may affect thermal transfer are not embedded in the compound.

6. Clean the surface of the heat sink and make sure it is free of debris.
7. Obtain a replacement device (modulator FETs are Nautel Part # QR75; free-wheel diodes are Nautel part # QK50) from the spares kit. Apply a thin film of thermal compound (Nautel Part # HAG39, from the ancillary kit) to the device.
8. Install the device on the heat sink using the punched hole in the heat sink as an alignment aid. Apply downward pressure on the device and wiggle it slightly left and right and up and down to release trapped air and excess thermal compound. Reinstall the heat sink clip removed in [Step 5](#).

**NOTE:** The thermal joint between a modulator FET or free-wheel diode and its heatsink is critical for the reliability of the device. Incorrectly installed thermal compound could result in significantly reduced lifetime for the device, or even immediate failure of the device. See Microsemi Application Note 1810 for a more detailed procedure on properly applying thermal compound for electronic devices.

See [http://www.microsemi.com/index.php?option=com\\_docman&task=doc\\_download&gid=14750](http://www.microsemi.com/index.php?option=com_docman&task=doc_download&gid=14750)

9. Re-install the heatsink on the PWB, first by soldering the two heatsink connections and then by soldering the device's leads:
  - ❖ For modulator FETs (Q11, Q12, Q13), solder the gate (G), drain (D) and source (S) connections.
  - ❖ For free-wheel diodes (CR19, CR20, CR21), solder the anode (A) and cathode (K) connections.
10. Replace any other defective devices and then reinstall the PWB to the chassis by reversing the instructions in steps 1, 2 and 3. Torque the 16 power amplifier MOSFET screws (four for each MOSFET) to a maximum of 10 in-lbs (1.1 N-m).
11. Return the power module to service (see "Installing an RF Power Module" on page 4.1.55).



---

## Control/Interface PWB Removal/Replacement

1. Record the following minimum information from the front panel UI and remote AUI, as applicable:
  - ❖ Scheduler page: record Rules and Daily Events information.
  - ❖ Factory Settings page: record all information in the RF Symmetry, SWR Thresholds, Transmitter Type, Transmitter Frequency and PDM Settings menus.
  - ❖ System Settings page: record all information in the Exciter Clock Calibration, RF Monitor Level, Power Lockout and Power Thresholds menus.
  - ❖ Remote I/O page: record all information for the user-defined remote Inputs and Outputs, including Channel and Control settings.
2. Set the transmitter to its RF Off state. Turn off (disable or lock out) the ac power at the source. Open the front door to gain access to the exciter panel (see [Figure 4.1.12 on page 4.1.66](#)).
3. Disconnect all cables attached to the control/interface PWB (A4), taking note of the connector labels on the cables and the PWB.
4. Remove and retain the two screws securing the connector bracket in the upper, left portion of the control/interface PWB.
5. Remove and retain 10 sets of mounting hardware from the control/interface PWB.
6. Gently remove the control/interface PWB away from the digital AM exciter PWB(s) and out of the transmitter.
7. Obtain a replacement control/interface PWB (Nautel Part # NAPC168A).
8. Set jumper E1 on the replacement PWB to the same position as E1 on the defective PWB.
9. Install the new control/interface PWB by reversing [Step 3](#) through [Step 6](#). For connector mating assistance, refer to the connector mating tables in [Section 4.3, "Wiring/Connector lists" on page 4.3.1](#).
10. Turn on (enable) the ac power source. Set the transmitter to its RF On state.
11. Upgrade the subsystem's software using the front panel UI's Updating Firmware screen or the remote AUI's Upgrade Software page under the appropriate System Settings menu, by running an upgrade using the existing .tgz file already installed on the transmitter. See the NX10 Operations and Maintenance Manual for detailed instructions.
12. Use the remote AUI's Meter List View page to verify that the meters for all installed Modules are populated. See the NX10 Operations and Maintenance Manual for detailed instructions.
13. Re-enter all the front panel UI and remote AUI information recorded in [Step 1](#).

Figure 4.1.12: NX10 Control/Exciter Panel

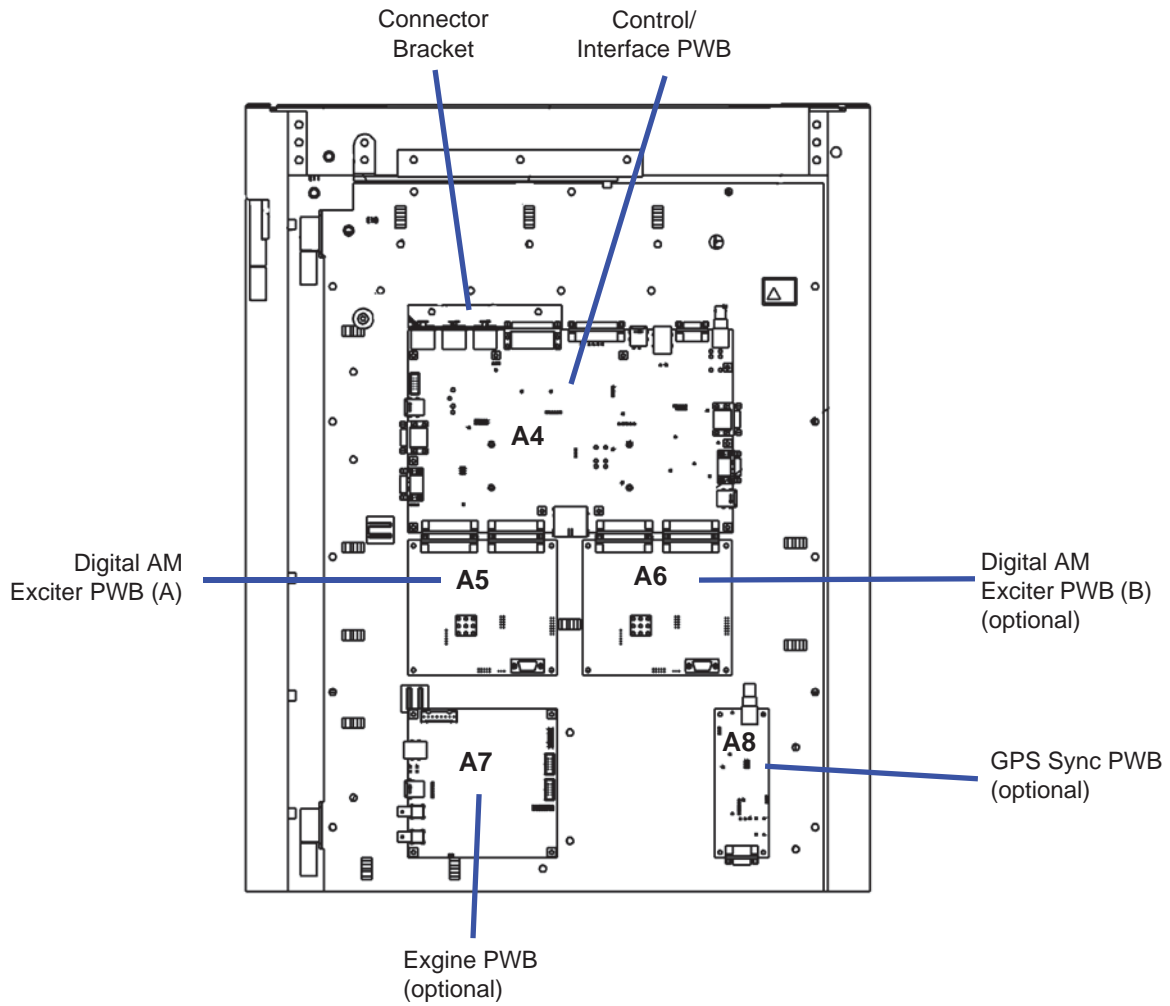

## SCR Rectifier Inspection/Replacement

**WARNING! LETHAL VOLTAGES EXIST INSIDE THE TRANSMITTER WHEN THE POWER IS TURNED ON. TURN OFF AND LOCK OUT THE POWER AT THE SOURCE AND WAIT UNTIL THE THREE AMBER LEDS IN THE BACK OF THE TRANSMITTER ARE OFF BEFORE REMOVING CONNECTIONS OR ASSEMBLIES.**

Figure 4.1.13: Location of SCR Rectifier Assembly A1

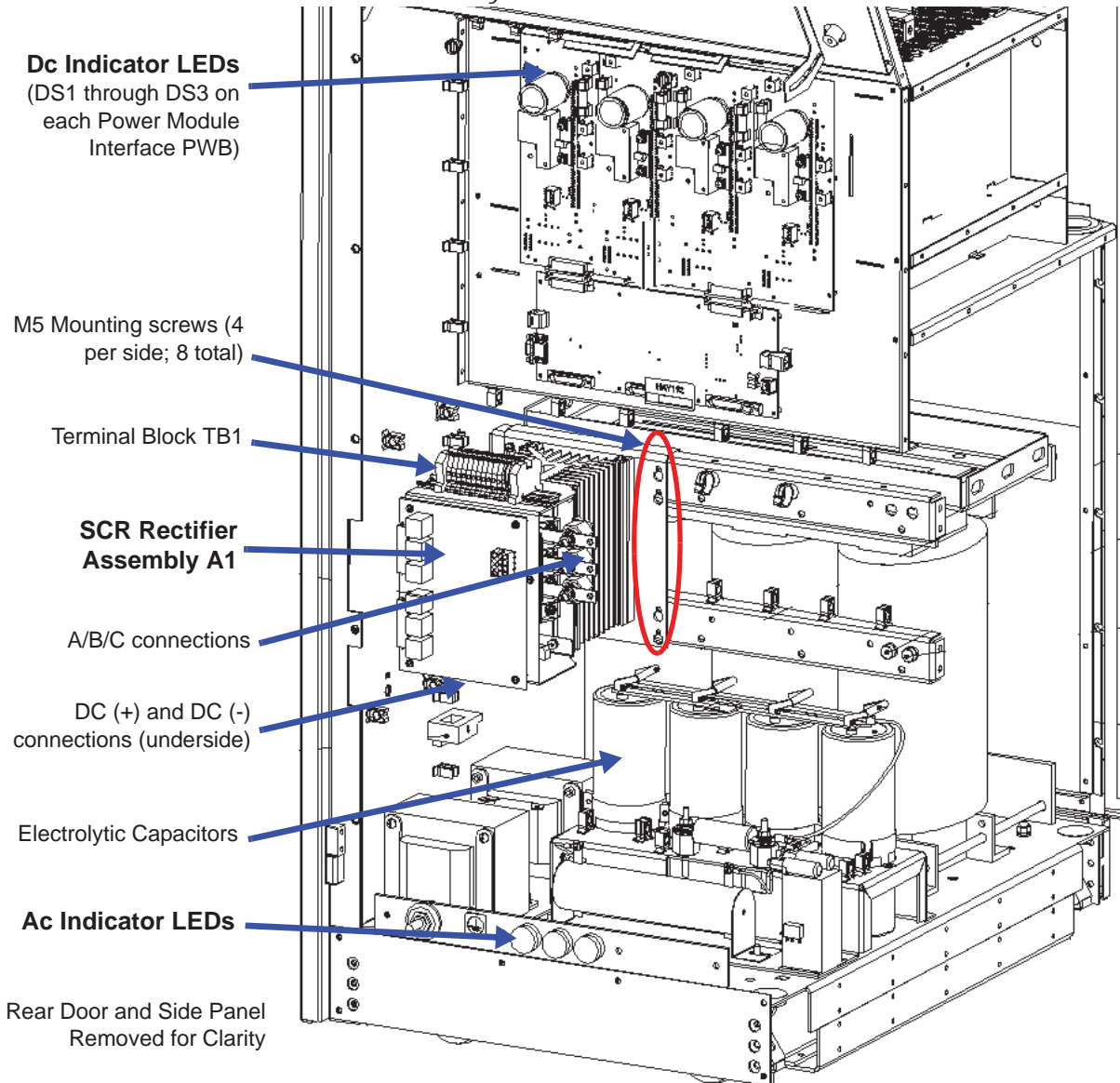

See [Figure 4.1.13](#) on [page 4.1.67](#).

1. Turn off (disable and lock out) the ac power at the source. When the three ac indicator LEDs are off (amber when on), open the rear door. Verify the three dc indicator LEDs on each power module interface PWB are off (amber when on). For additional safety, measure the dc voltage across the + and - terminals of any of the four, electrolytic capacitors. Open the lower, front panel to access the power transformer's terminals and measure all line-to-line and line-to-neutral ac voltages. There should be little or no ac or dc voltage. **DO NOT PROCEED** if the dc voltage is greater than 5 V.
2. Disconnect all wiring attached to the SCR rectifier assembly's A (Line 1), B (Line 2), C (Line 3), DC (+), DC (-) and TB1 terminals, taking note of the wiring labels.
3. Loosen, but do not remove, the eight (8) sets of M5 mounting hardware that support the SCR rectifier assembly.
4. Carefully lift and remove the SCR rectifier assembly from the transmitter.
5. Obtain a replacement SCR rectifier assembly (Nautel Part # 212-7055).
6. Reverse [Step 2](#) through [Step 4](#) to reinstall the new or repaired SCR rectifier assembly. Ensure all connections are tight, noting that connections to the A, B, C, DC (+) and DC (-) terminals have special torque requirements. Torque these wires to 60 in-lbs (6.7 N-m). Torque TB1 connections to 4 in-lbs (0.45 N-m).
7. Re-install the lower, front panel over the power transformer. Close and secure the rear door. Turn on (enable) the ac power source and resume transmitter operation.

## Digital AM Exciter PWB Replacement

**NOTE:** To ensure the transmitter recognizes exciter PWBs being installed, exciter PWBs must be programmed with software version equivalent to NX SW 4.4 or newer.

1. Set the transmitter to its RF Off state. Open the front door to gain access to the exciter panel (see Figure 4.1.12 on page 4.1.66).
2. Connect a straight-through serial (DB9) cable between the defective digital AM exciter PWB's RS-232 connector (9-pin D-sub J3, see Figure 4.1.14) and the serial port on a PC. See Figure 4.1.12 on page 4.1.66 to locate the digital AM exciter PWB(s) (A5 and A6, if purchased).

Figure 4.1.14: Part of Digital AM Exciter PWB - Location of RS-232 Connector J3

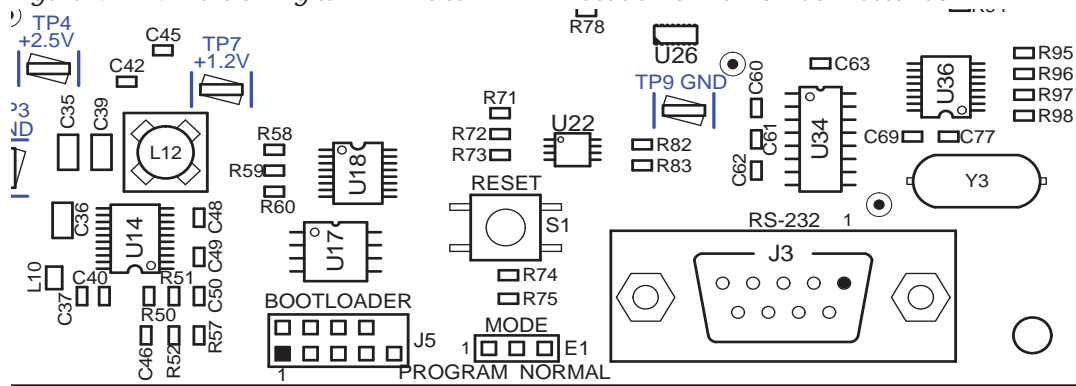

3. On MODE program header E1 (see Figure 4.1.14), install the shorting jumper in the PROGRAM position (shorting pins 1 and 2). Press RESET switch S1, located directly above E1.
4. Obtain the NCode Uploader application from Nautel's FTP site:  
<ftp://www3.nautel.com/Utilities/NCodeUploader/>
5. From the PC, run the NCode Uploader application (see Figure 4.1.15 on page 4.1.70). Click Settings and ensure the COM port reflects the port that the serial cable is connected to on your PC.

Figure 4.1.15: NCode Uploader Menu

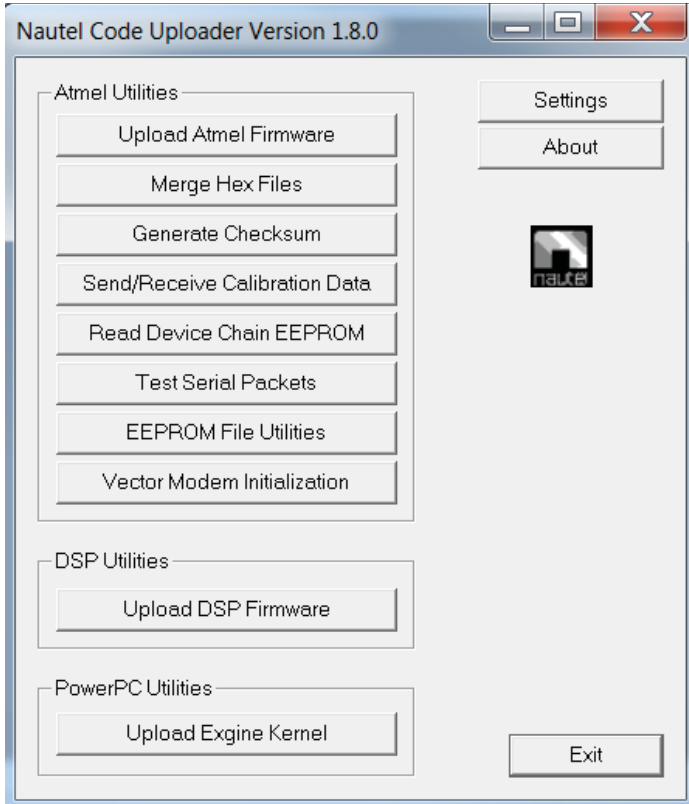
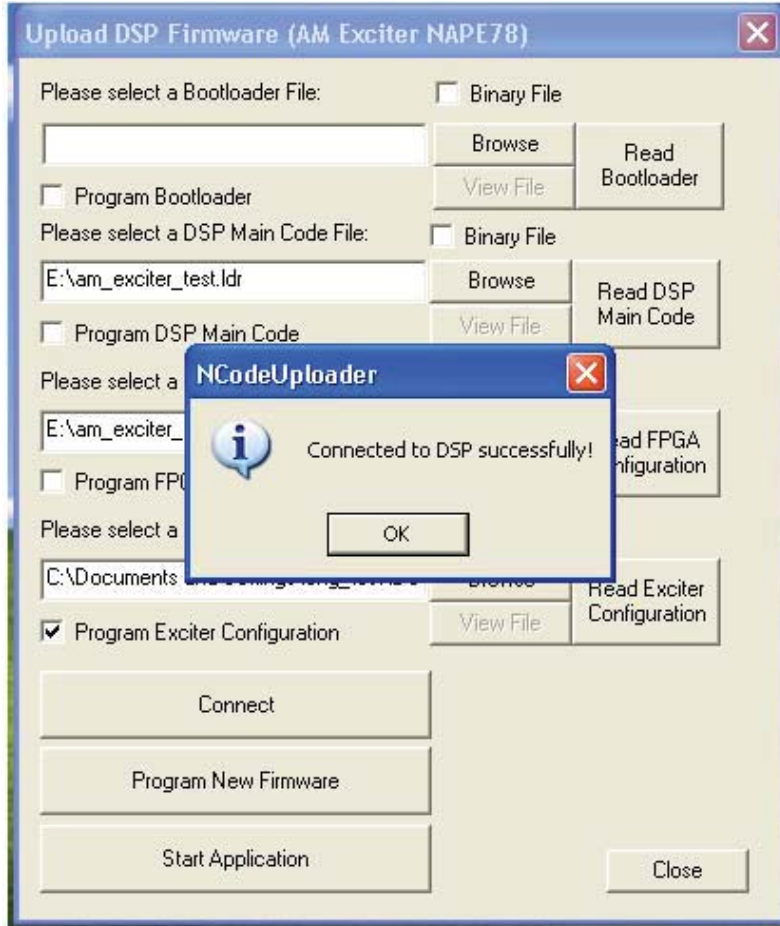
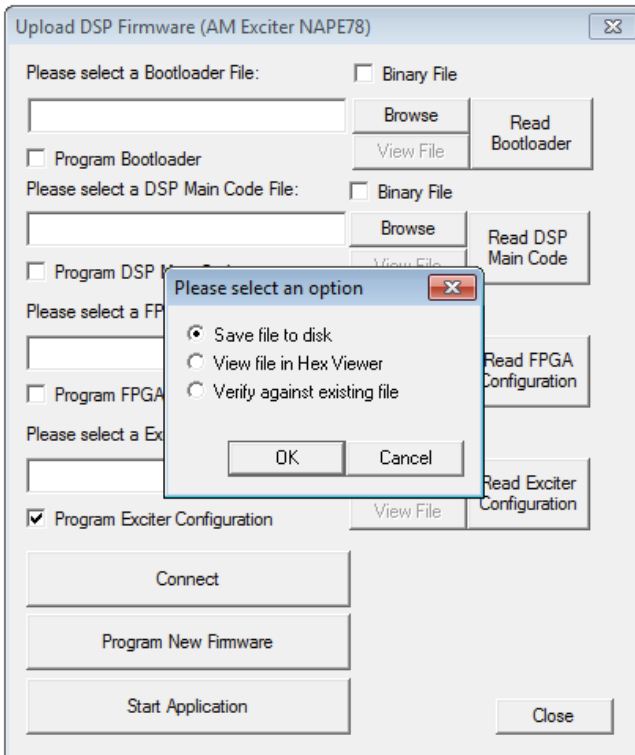

Figure 4.1.16: Upload DSP Firmware Menu



6. Click the Upload DSP Firmware button (see [Figure 4.1.15](#) on page 4.1.70). The menu shown in [Figure 4.1.16](#) should appear, along with the Connected to DSP successfully! prompt. Click OK.
7. Once connected, click the Read Exciter Configuration button. Select Save file to disk and click OK (see [Figure 4.1.17](#) on page 4.1.72) to save the current calibration data. Browse to a desired location to save the file.
8. If the defective exciter does not allow the previous steps to be performed, try using the operational exciter to save the required calibration data. In this case, repeat [Step 2](#) through [Step 7](#) for the operational exciter's digital AM exciter PWB. If there is no operational exciter, contact Nautel for the required calibration data.

Figure 4.1.17: Upload DSP Firmware Menu - Select an Option



9. Turn off (disable) the ac power for the transmitter at the source. Remove and retain four sets of mounting hardware from the digital AM exciter PWB being replaced (A5 or A6).
10. Pull the digital AM exciter PWB away from the control/interface PWB (A4). It may be helpful to gently pry the connectors loose with a screwdriver.
11. Obtain a replacement digital AM exciter PWB (Nautel Part # NAPE78A/01).
12. Install the new digital AM exciter PWB by reversing [Step 9](#) and [Step 10](#).
13. Turn on (enable) the ac power source.
14. Connect a straight-through serial (DB9) cable between the replacement digital AM exciter PWB's RS-232 connector (9-pin D-sub J3, see [Figure 4.1.14 on page 4.1.69](#)) and the serial port on a PC.
15. On the digital AM exciter PWB's MODE program header E1 (see [Figure 4.1.14 on page 4.1.69](#)), install the shorting jumper in the PROGRAM position (shorting pins 1 and 2). Press RESET switch S1, located directly above E1.
16. Once connected, use the PC to browse to the configuration file saved in [Step 7](#) by clicking the Browse button next to the "Please Select a Exciter Configuration file:" field (see [Figure 4.1.18 on page 4.1.73](#)).



Figure 4.1.18: Upload DSP Firmware Menu - Browse for configuration file

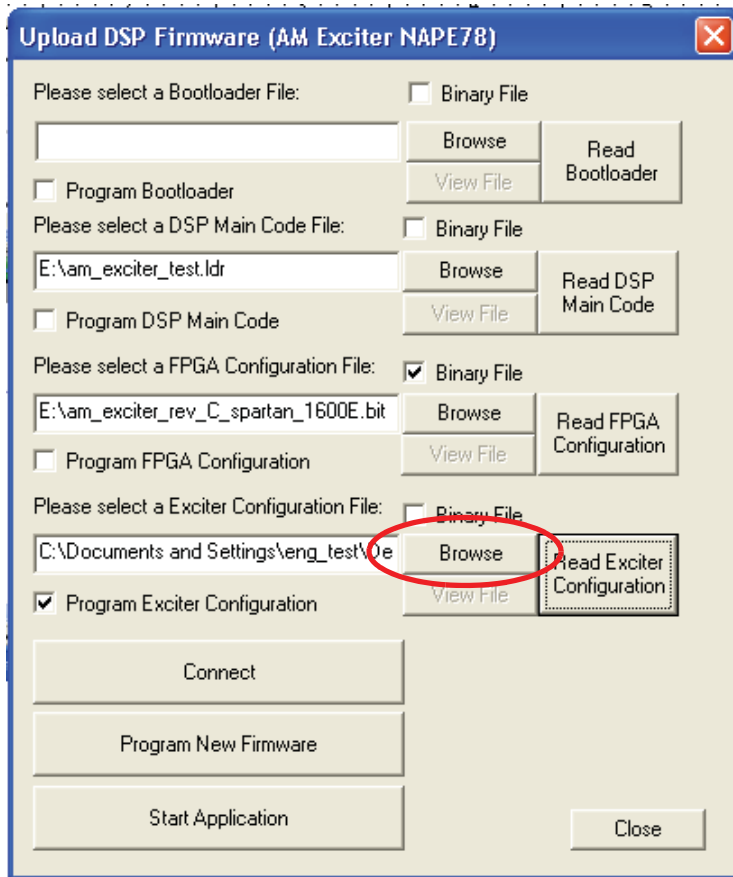

17. Click the Program Exciter Configuration checkbox (see Figure 4.1.18) so that the box contains a checkmark. Ensure the Program Bootloader, Program DSP Main Code and Program FPGA Configuration checkboxes are not checked. Click the Program New Firmware button.
18. On the digital AM exciter PWB’s MODE program header E1 (see Figure 4.1.14 on page 4.1.69), return the shorting jumper to the NORMAL position (shorting pins 2 and 3). Press RESET switch S1, located directly above E1.
19. Using the front panel UI or remote AUI, reset any active alarms.
20. Upgrade the subsystem’s software using the front panel UI’s Updating Firmware screen or the remote AUI’s Upgrade Software page under the appropriate System Settings menu, by running an upgrade using the existing .tgz file already installed on the transmitter. See the NX10 Operations and Maintenance Manual for detailed instructions.
21. Set the transmitter to its RF On state. Ensure any previously present alarms have cleared.

---

## Exgine PWB Replacement

1. Set the transmitter to its RF Off state. Turn off (disable) the ac power at the source. Open the front door to gain access to the exciter panel (see [Figure 4.1.12 on page 4.1.66](#)).
2. Disconnect all cables attached to the Exgine PWB (A7), taking note of the connector labels on the cables and the PWB.
3. Carefully remove and retain the four (4) sets of mounting hardware and remove the Exgine PWB from the exciter panel.
4. Obtain a replacement Exgine PWB (Nautel Part # NAPE74C/01).
5. Install the new Exgine PWB by reversing [Step 2](#) and [Step 3](#). Ensure all connections are tight. For connector mating assistance, refer to the connector mating tables in [Section 4.3, "Wiring/Connector lists" on page 4.3.1](#).
6. Turn on (enable) the ac power source. Set the transmitter to its RF On state. Ensure any previously present alarms have cleared.

## GPS Sync PWB Replacement

1. Set the transmitter to its RF Off state. Turn off (disable) the ac power at the source. Open the front door to gain access to the exciter panel (see [Figure 4.1.12 on page 4.1.66](#)).
2. Disconnect all cables attached to the GPS sync PWB (A8), taking note of the connector labels on the cables and the PWB.
3. Carefully remove and retain the four (4) sets of mounting hardware and remove the GPS sync PWB from the exciter panel.
4. Obtain a replacement GPS sync PWB (Nautel Part # NAPX46). Remove the jack screws from 9-pin D-sub connector J1 on the new GPS sync PWB before installing it.
5. Set the jumpers on the replacement PWB to the same positions as the defective PWB.
6. Install the new GPS sync PWB by reversing [Step 2](#) and [Step 3](#). Ensure all connections are tight. For connector mating assistance, refer to the connector mating tables in [Section 4.3, "Wiring/Connector lists" on page 4.3.1](#).
7. Turn on (enable) the ac power source. Set the transmitter to its RF On state. Ensure any previously present alarms have cleared.

## Rack Interface PWB Replacement

**WARNING! LETHAL VOLTAGES EXIST INSIDE THE TRANSMITTER WHEN THE POWER IS TURNED ON. TURN OFF AND LOCK OUT THE POWER AT THE SOURCE AND WAIT UNTIL THE THREE AMBER LEDS IN THE BACK OF THE TRANSMITTER ARE OFF BEFORE REMOVING CONNECTIONS OR ASSEMBLIES.**

Figure 4.1.19: Location of Rack Interface PWB

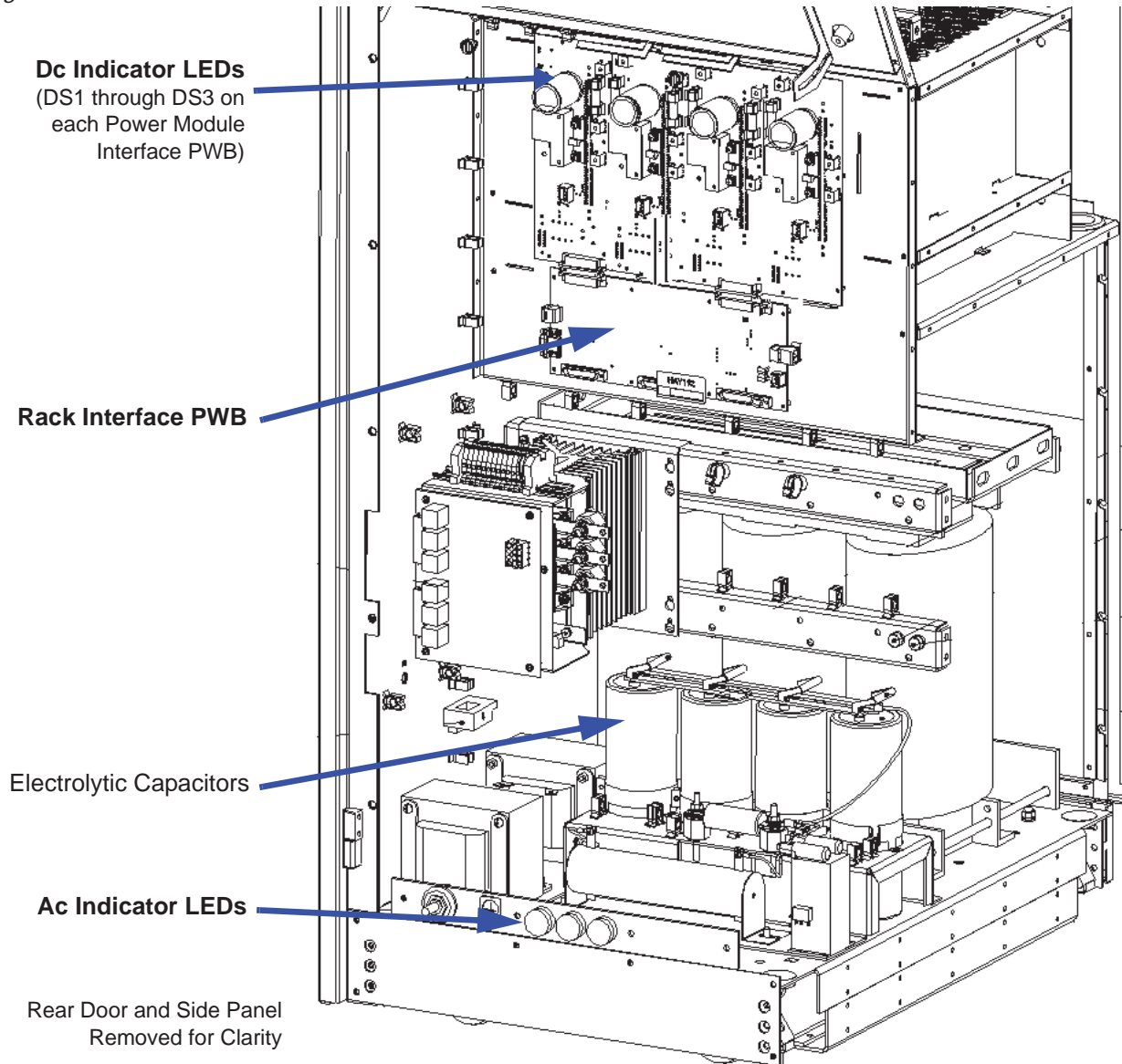

See [Figure 4.1.19](#) on [page 4.1.75](#).

1. Turn off (disable and lock out) the ac power at the source. When the three ac indicator LEDs are off (amber when on), open the rear door. Verify the three dc indicator LEDs on each power module interface PWB are off (amber when on). For additional safety, measure the dc voltage across the + and - terminals of any of the four, electrolytic capacitors. Open the lower, front panel to access the power transformer's terminals and measure all line-to-line and line-to-neutral ac voltages. There should be little or no ac or dc voltage. **DO NOT PROCEED** if the dc voltage is greater than 5 V.
2. Disconnect all cables attached to the rack interface PWB (A9), taking note of the connector labels on the cables and the PWB.
3. Carefully remove and retain the eight (8) sets of mounting hardware and remove the rack interface PWB from the transmitter.
4. Obtain a replacement rack interface PWB (Nautel Part # NAPI173A).
5. Reverse [Step 2](#) through [Step 3](#) to install the replacement PWB. Ensure all connections are tight. For connector mating assistance, refer to the connector mating tables in [Section 4.3, "Wiring/Connector lists"](#) on [page 4.3.1](#).
6. Before restoring ac power, remove the four RF power modules from the transmitter (see ["Removing and Reinstalling RF Power Modules"](#) on [page 4.1.52](#)).
7. Re-install the lower, front panel over the power transformer. Close and secure the rear door. Turn on (enable) the ac power source.
8. One at a time, reinstall each RF power module. The LED sequence on the front panel of each module should change to solid red. Reconnect each RF power module's PDM cable; the LED sequence should change to flashing amber.
9. Load the subsystem software (existing .tgz file) using the front panel UI's Updating Firmware screen or the remote AUI's Upgrade Software page under the appropriate System Settings menu. See the NX10 Operations and Maintenance Manual for detailed instructions.
10. Set the transmitter to its RF On state. Ensure any previously present alarms have cleared.

## Power Module Interface PWB Replacement

**WARNING! LETHAL VOLTAGES EXIST INSIDE THE TRANSMITTER WHEN THE POWER IS TURNED ON. TURN OFF AND LOCK OUT THE POWER AT THE SOURCE AND WAIT UNTIL THE THREE AMBER LEDS IN THE BACK OF THE TRANSMITTER ARE OFF BEFORE REMOVING CONNECTIONS OR ASSEMBLIES.**

Figure 4.1.20: Location of Power Module Interface PWBs

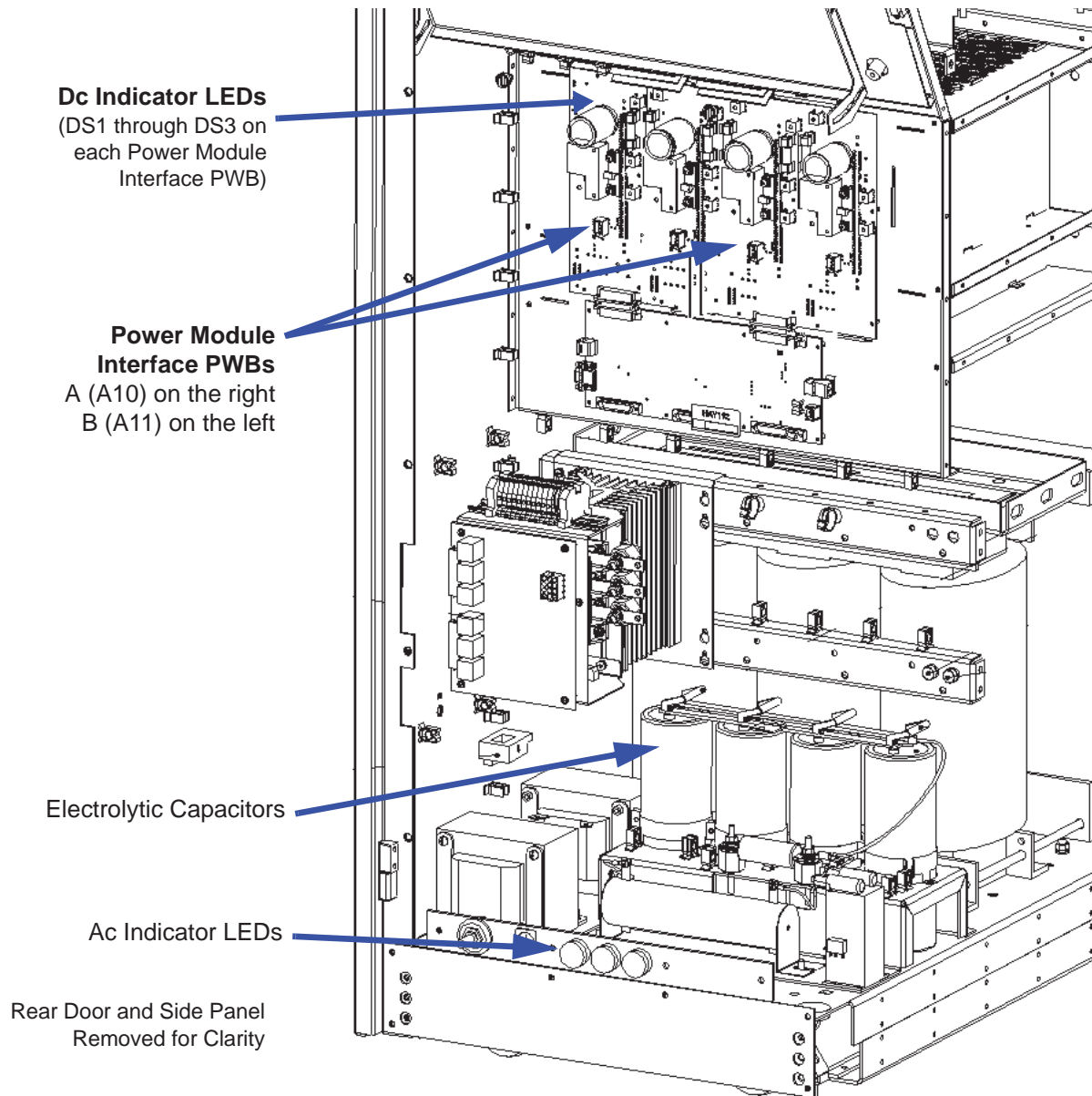

See [Figure 4.1.20](#) on [page 4.1.77](#).

1. Turn off (disable and lock out) the ac power at the source. When the three ac indicator LEDs are off (amber when on), open the rear door. Verify the three dc indicator LEDs on each power module interface PWB are off (amber when on). For additional safety, measure the dc voltage across the + and - terminals of any of the four, electrolytic capacitors. Open the lower, front panel to access the power transformer's terminals and measure all line-to-line and line-to-neutral ac voltages. There should be little or no ac or dc voltage. **DO NOT PROCEED** if the dc voltage is greater than 5 V.
2. Disconnect all wiring and cables attached to the suspect power module interface PWB (A10 or A11), taking note of the connector labels on the cables and the PWB. Pay particular attention to the difference in shrink-wrap colour on the wires connected to E4/E8 and E6/E10.
3. From the front of the transmitter, remove the two RF power modules and two fan trays associated with the suspect power module interface PWB.
4. Remove the two gas discharge PWBs and two relays from the suspect power module interface PWB as detailed in "[Gas Discharge PWB and Relay Replacement](#)" on [page 4.1.79](#).
5. Carefully remove and retain the 16 sets of mounting hardware from the suspect power module interface PWB (A10 or A11) and remove the power module interface PWB from the transmitter. **NOTE:** There are more than 16 screws in each power module interface PWB. The mounting hardware is located on the square pads of the PWB.
6. Obtain a replacement power module interface PWB (Nautel Part # NAPI174).
7. Install the new PWB by reversing [Step 2](#) through [Step 5](#), including the re-installation of the two gas discharge PWBs and relays. Ensure all connections are tight, noting that connections to terminals E1, E2, E4, E6, E8 and E10 have special torque requirements. Torque these wires to 20 in-lbs (2.2 N-m).
8. Re-install the lower, front panel over the power transformer. Close and secure the rear door. Turn on (enable) the ac power source and resume transmitter operation. Ensure any previously present alarms have cleared.

## Gas Discharge PWB and Relay Replacement

**WARNING! LETHAL VOLTAGES EXIST INSIDE THE TRANSMITTER WHEN THE POWER IS TURNED ON. TURN OFF AND LOCK OUT THE POWER AT THE SOURCE AND WAIT UNTIL THE THREE AMBER LEDS IN THE BACK OF THE TRANSMITTER ARE OFF BEFORE REMOVING CONNECTIONS OR ASSEMBLIES.**

Figure 4.1.21: Location of Gas Discharge PWB and Relays

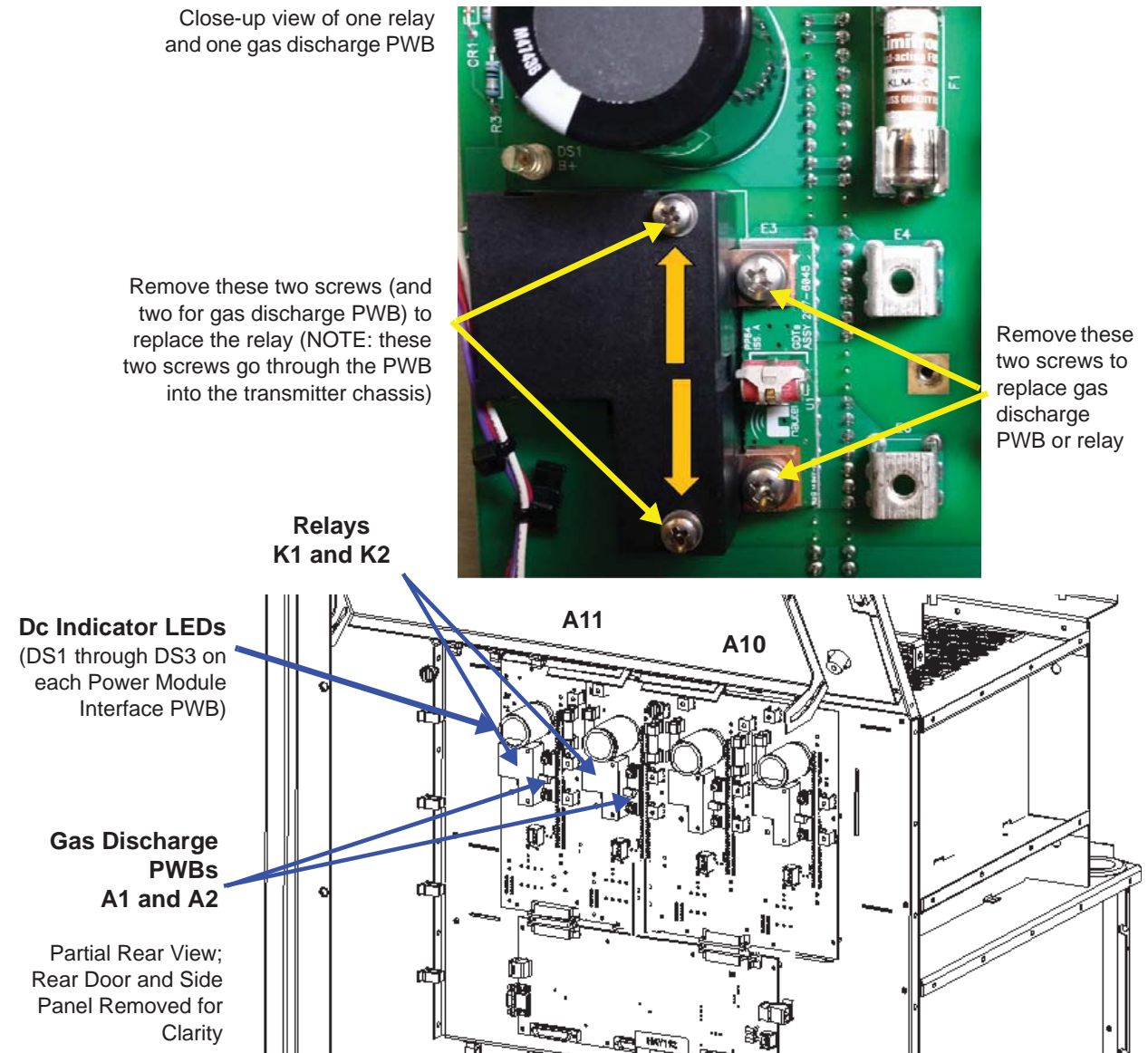



1. Turn off (disable and lock out) the ac power at the source. When the three ac indicator LEDs are off (amber when on), open the rear door. Verify the three dc indicator LEDs on each power module interface PWB are off (amber when on). For additional safety, measure the dc voltage across the + and - terminals of any of the four, electrolytic capacitors. Open the lower, front panel to access the power transformer's terminals and measure all line-to-line and line-to-neutral ac voltages. There should be little or no ac or dc voltage. **DO NOT PROCEED** if the dc voltage is greater than 5 V.
2. Remove and retain the two sets of mounting hardware from the suspect gas discharge PWB (A10A1, A10A2, A11A1 or A11A2) or four sets of mounting hardware from the suspect relay (A10K1, A10K2, A11K1 or A11K2). See [Figure 4.1.21 on page 4.1.79](#) and Figure MD-9 in the Mechanical Drawings section of this manual. Note the orientation of the Belleville washers that secure the relay and gas discharge PWB to the power module interface PWB terminals (see [Figure 4.1.22 on page 4.1.80](#)).
3. Remove the defective PWB(s) or relay(s).

Figure 4.1.22: Orientation of Belleville Washers

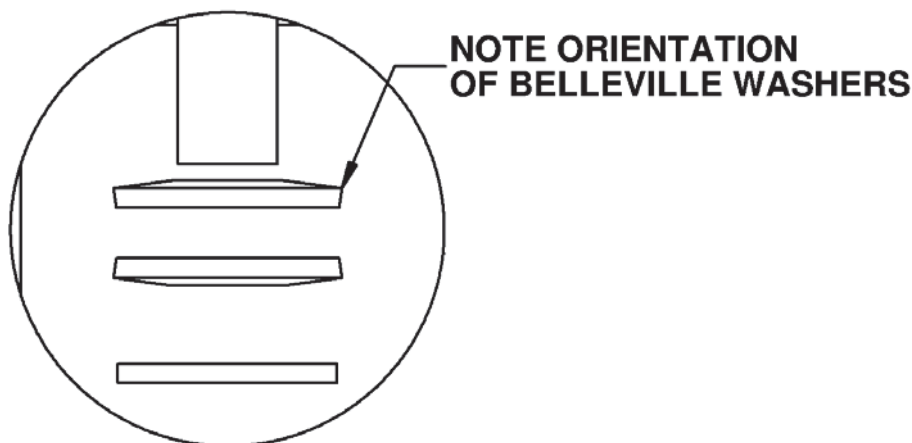

4. Install the new PWB or relay by reversing [Step 2](#) and [Step 3](#). Use new Belleville washers (Nautel Part # HM49) and torque to 12 in-lbs to secure the relays.
5. Re-install the lower, front panel over the power transformer. Close and secure the rear door. Turn on (enable) the ac power source and resume transmitter operation. Ensure the offending alarm has cleared.



## Fan Tray Replacement

**NOTE:** Fan tray replacement can be performed with the transmitter 'on-air' (RF On).

Figure 4.1.23: Location of Fan Tray Assemblies

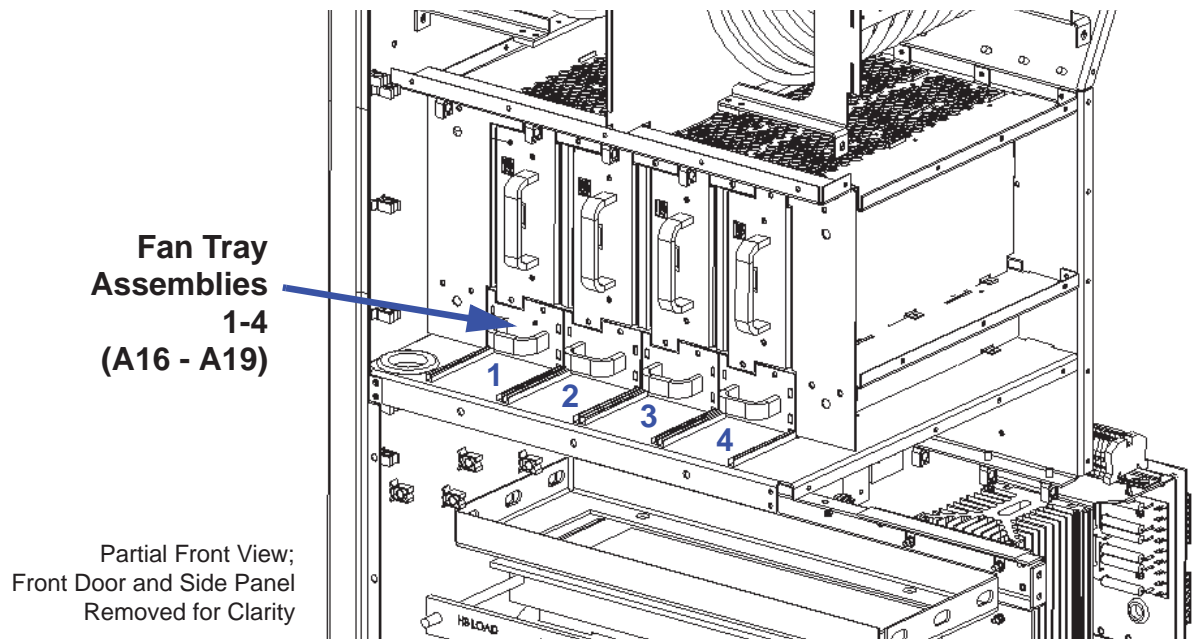

1. Open the front door.
2. Locate the suspect fan tray assembly [1 (A16) through 4 (A19)] associated with the RF Power Module 1-4 alarm(s) (see [Figure 4.1.23](#)).
3. Remove and retain the two sets of mounting hardware.

**CAUTION!** If one of the fans in the tray is still operational, its blades may still be rotating. Be careful to keep fingers away from fan blades.

4. Pull the fan tray assembly out of the transmitter.
5. Obtain a replacement fan tray (Nautel Part # NAX274).
6. Install the new fan tray in the transmitter and secure using retained screws. Ensure the offending alarm has cleared.

**NOTE:** You can also replace an individual fan of a fan tray assembly. See "[Fan Tray Cooling Fan Replacement](#)" on page 4.1.82.

## Fan Tray Cooling Fan Replacement

1. Remove the fan tray assembly [1 (A16) through 4 (A19)] that contains the suspect fan as detailed in "Fan Tray Replacement" on page 4.1.81.
2. Disconnect the suspect fan's mating plug (B1P1 or B2P1) (see Figure 4.1.24).
3. Remove and retain the cooling fan's two M3 screws that secure the fan to the fan tray, along with the spacer sleeves that are installed between the two ears of the fan.
4. Obtain a replacement fan (Nautel Part # ZAP50) from the site spares kit, if purchased (vendor part # is Minebea Motor Mfg. Corp. 3115RL-07W-B79-E51).
5. Install the replacement fan using retained screws and spacers, ensuring correct orientation for proper air flow. Check the position of the other fan as a reference.
6. Reinstall the fan tray in the transmitter and secure using retained screws. Ensure the offending alarm has cleared.

Figure 4.1.24: Fan Tray Assembly Cooling Fans (B1 and B2)

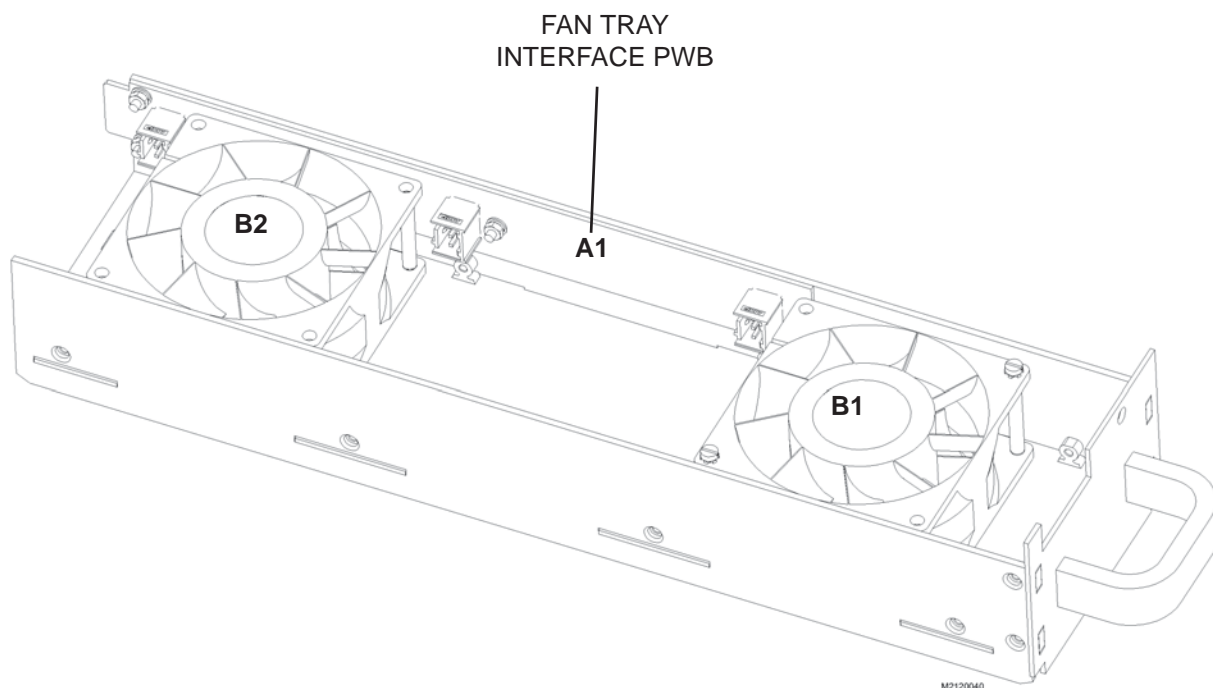

## RF Voltage and Current Sample PWB Replacement

**WARNING! LETHAL VOLTAGES EXIST INSIDE THE TRANSMITTER WHEN THE POWER IS TURNED ON. TURN OFF AND LOCK OUT THE POWER AT THE SOURCE AND WAIT UNTIL THE THREE AMBER LEDS IN THE BACK OF THE TRANSMITTER ARE OFF BEFORE REMOVING CONNECTIONS OR ASSEMBLIES.**

Figure 4.1.25: Location of RF Voltage and Current Sample PWB

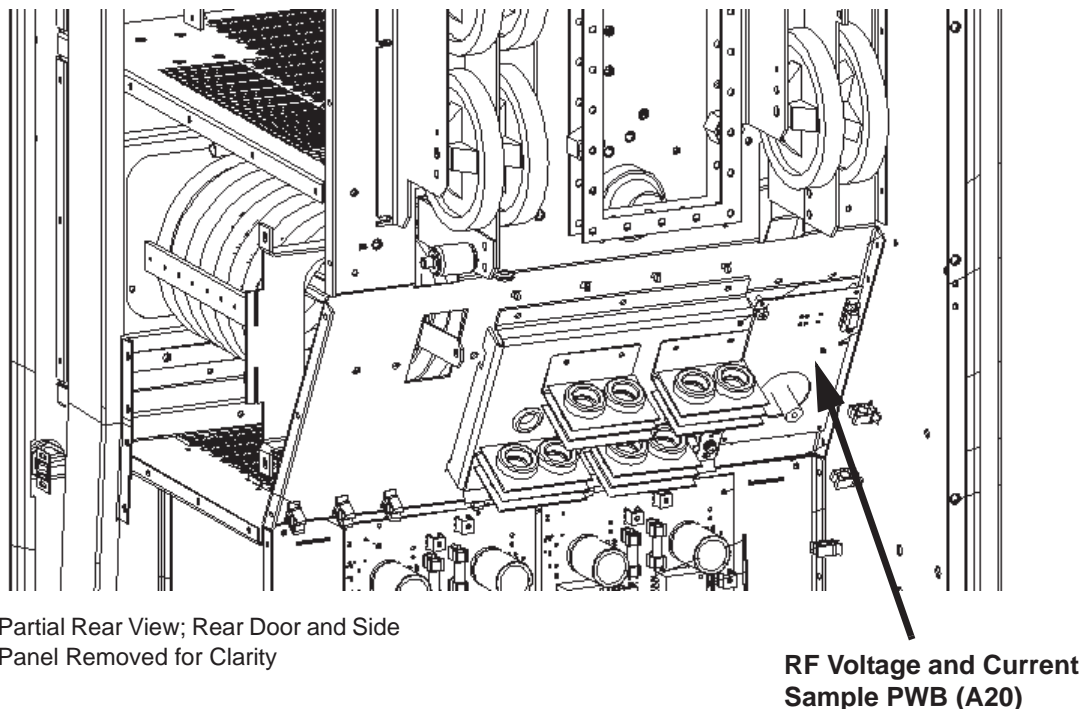

1. Turn off (disable and lock out) the ac power at the source. When the three ac indicator LEDs are off (amber when on), open the rear door. Verify the three dc indicator LEDs on each power module interface PWB are off (amber when on). For additional safety, measure the dc voltage across the + and - terminals of any of the four, electrolytic capacitors. Open the lower, front panel to access the power transformer's terminals and measure all line-to-line and line-to-neutral ac voltages. There should be little or no ac or dc voltage. **DO NOT PROCEED** if the dc voltage is greater than 5 V.
2. Disconnect all cables attached to the RF voltage and current sample PWB (A20) (see [Figure 4.1.25](#)), taking note of the connector labels on the cables and the PWB.
3. Remove the four (4) sets of hardware that secure the cover plate for the RF voltage and current sample PWB.

4. Carefully remove and retain the four (4) sets of mounting hardware from the RF voltage and current sample PWB and remove the PWB from the transmitter.
5. Obtain a replacement RF voltage and current sample PWB (Nautel Part # NAPP11/02A).
6. Install the new PWB by reversing [Step 2](#) through [Step 4](#). Ensure all connections are tight, noting that the connection to terminal E1 has a special torque requirement. Torque this wire to 10 in-lbs (1.1 N-m).
7. Re-install the lower, front panel over the power transformer. Close and secure the rear door. Turn on (enable) the ac power source and resume transmitter operation.
8. Perform a re-calibration of the transmitter (see ["Re-Calibrating the Transmitter"](#)).

## Re-Calibrating the Transmitter

You will need the following test equipment to perform the re-calibration:

- ❖ Calibration values from Nautel Customer Service: 1st Inductor Value, Filter Lag and Ideal PA Impedance
  - ❖ 50-ohm test load, rated for full power including modulation
  - ❖ Impedance measuring device capable of measuring impedance (both resistive and reactive)
  - ❖ RF current probe with RMS meter
1. Disable and lock out the ac power source for the transmitter. Terminate the transmitter's RF output into the test load.
  2. Measure and record the test load impedance at the transmitter's RF output (include the hardline between the transmitter and test load in the measurement), at the transmitter's carrier frequency.

**NOTE:** If the current probe is not in line at the output of the transmitter, measure the test load impedance seen at both the output of the transmitter ( $Z_{\text{Transmitter\_Output}}$ ) and the position of the current probe ( $Z_{\text{Position of Current Probe}}$ ).

3. Calculate the rated RF current as follows:

$$I_{\text{Rated}} = \sqrt{\frac{P_{\text{Rated}}}{R_{\text{Position of RF Current Probe}}}}$$

Figure 4.1.26: Forward/Reflected Power Screen on Remote AUI

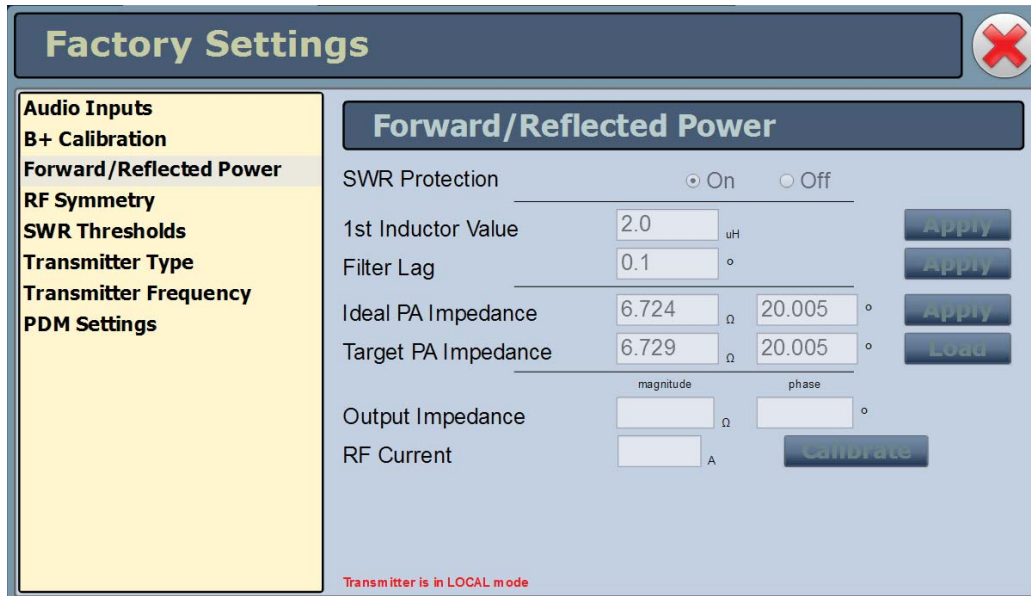

4. Enable the ac power source for the transmitter.
5. Set the RF output power to 5% of rated power. In the remote AUI’s Menu -> Factory Settings -> Forward/Reflected Power screen (see [Figure 4.1.26 on page 4.1.85](#)), set SWR Protection to Off. Press RF On. Measure the RF current on the RF current probe.
6. Calculate the transmitter output current as follows:

$$I_{Transmitter Output} = \sqrt{\frac{I_{Measured} \times R_{Position of RF Current Probe}}{R_{Transmitter Output}}}$$

**NOTE:**  $I_{measured}$  is the RF current probe measurement

7. In the remote AUI’s Menu -> Factory Settings -> Forward/Reflected Power screen (see [Figure 4.1.26](#)), enter the test load impedance measurement from [Step 2](#) in the Output Impedance field. Enter the transmitter output current calculated in [Step 4](#) in the RF Current field. Press Calibrate to begin calibrating.
 

**NOTE:** On the Forward/Reflected Power screen, the 1st Inductor Value, Filter Lag and Ideal PA Impedance fields should already contain values. Contact Nautel Customer Service to ensure the values are correct.
8. When the calibration routine is complete (indicated at the bottom of the Forward/Reflected Power screen), set SWR Protection to On.
9. Verify the RF current probe reads 22.5% ± 5% of the rated RF current calculated in [Step 3](#).

10. Ensure the RMS Envelope Magnitude meter in the upper, right corner of the remote AUI reads within  $\pm 1\%$  of the ideal value, noting the ideal value is calculated as follows:

$$\text{Ideal Value} = \frac{163 \text{ V} \times \% \text{ Volts}}{\sqrt{\frac{50}{\text{Exciter Carrier Impedance}}}} / \text{Exciter B+ Sample} \times 100\%$$

**NOTE:**

- ❖ % Volts = 22.5%/100
  - ❖ Exciter Carrier Impedance (see meters) displays in rectangular form; convert to polar form and use only the magnitude
  - ❖ Exciter B+ Sample (see meters)
11. Increase the RF output power to 10% of rated power. Measure the RF current on the RF current probe. The RF current should be  $31.5\% \pm 5\%$  of the rated RF current in [Step 3](#). Use the formula from [Step 10](#) ( $\% \text{ Volts} = 31.5\%/100$ ) to ensure the RMS Envelope Magnitude meter is within  $\pm 1\%$  of the ideal value. If not, enter the test load impedance measurement from [Step 2](#) in the Output Impedance field. Use the RF current measurement in this step to calculate the transmitter output current (see [Step 4](#)) and enter the calculated result in the RF Current field. Press Calibrate. When the calibration routine is complete (indicated at the bottom of the Forward/Reflected Power screen), verify the new RF Current and RMS Envelope Magnitude values are correct.
  12. Increase the RF output power to 50% of rated power. Measure the RF current on the RF current probe. The RF current should be  $71\% \pm 5\%$  of the rated RF current in [Step 3](#). Use the formula from [Step 10](#) ( $\% \text{ Volts} = 71\%/100$ ) to ensure the RMS Envelope Magnitude meter is within  $\pm 1\%$  of the ideal value. If not, enter the test load impedance measurement from [Step 2](#) in the Output Impedance field. Use the RF current measurement in this step to calculate the transmitter output current (see [Step 4](#)) and enter the calculated result in the RF Current field. Press Calibrate. When the calibration routine is complete (indicated at the bottom of the Forward/Reflected Power screen), verify the new RF Current and RMS Envelope Magnitude values are correct.
  13. Increase the RF output power to 100% of rated power. Measure the RF current on the RF current probe. The RF current should be  $100\% \pm 5\%$  of the rated RF current in [Step 3](#). Use the formula from [Step 10](#) ( $\% \text{ Volts} = 100\%/100$ ) to ensure the RMS Envelope Magnitude meter is within  $\pm 1\%$  of the ideal value. If not, enter the test load impedance measurement from [Step 2](#) in the Output Impedance field. Use the RF current measurement in this step to calculate the transmitter output current (see [Step 4](#)) and enter the calculated result in the RF Current field. Press Calibrate. When the calibration routine is complete (indicated at the bottom of the Forward/Reflected Power screen), verify the new RF Current and RMS Envelope Magnitude values are correct.
  14. Verify VSWR Protection is enabled (set to On).
  15. Select exciter B, if applicable, and repeat [Step 5](#) through [Step 14](#).
  16. Return the transmitter to normal operation.

## Directional Coupler Replacement

**WARNING! LETHAL VOLTAGES EXIST INSIDE THE TRANSMITTER WHEN THE POWER IS TURNED ON. TURN OFF AND LOCK OUT THE POWER AT THE SOURCE AND WAIT UNTIL THE THREE AMBER LEDS IN THE BACK OF THE TRANSMITTER ARE OFF BEFORE REMOVING CONNECTIONS OR ASSEMBLIES.**

Figure 4.1.27: Location of Directional Coupler Assembly

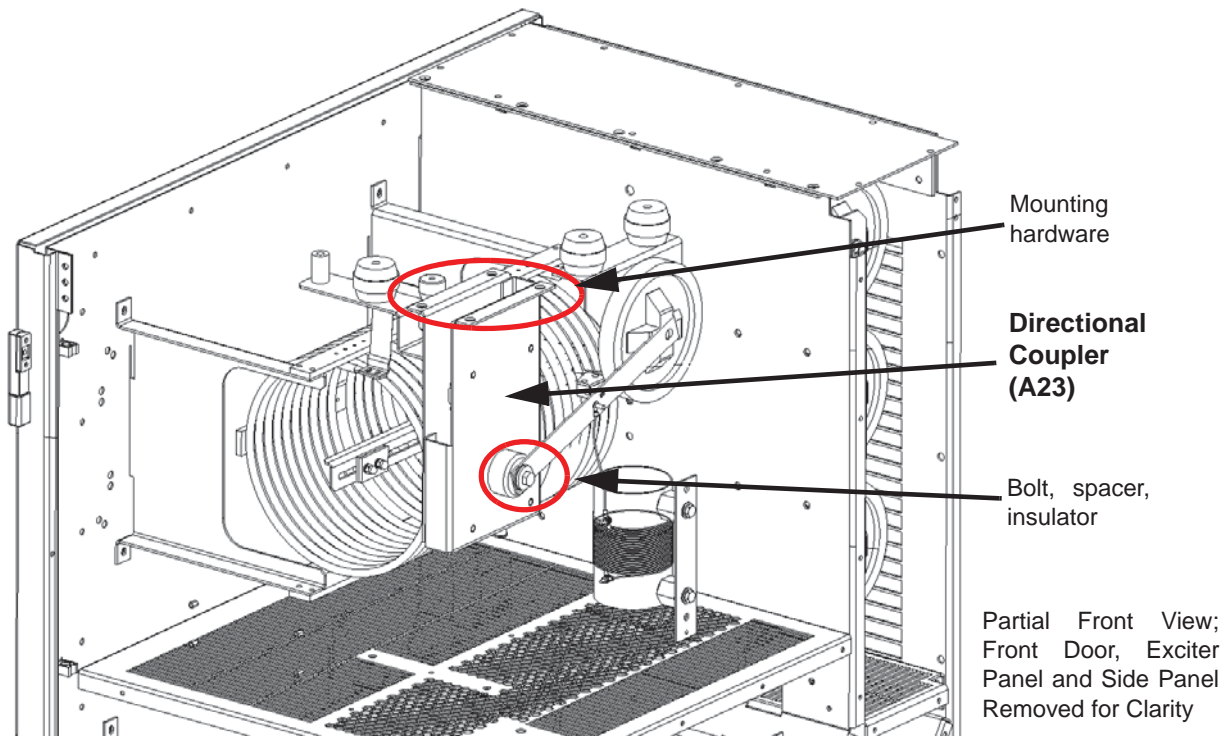

1. Set the transmitter to its RF Off state. Turn off (disable and lock out) the ac power at the source. Open the front door to gain access to the exciter panel. Remove 16 screws that secure the exciter panel and open the exciter panel to gain access to the directional coupler (A23) (see [Figure 4.1.27](#)).
2. Disconnect all cables attached to the directional coupler, taking note of the connector labels on the cables and the assembly.
3. Remove the bolt, spacer and associated hardware from inside the insulator on the directional coupler.
4. Carefully remove and retain the four (4) sets of mounting hardware at the top of the cabinet and remove the directional coupler from the transmitter.



- 
5. Obtain a replacement directional coupler (Nautel Part # NAFP112).
  6. Install the new directional coupler by reversing [Step 2](#) through [Step 4](#), noting that a new bolt, sleeve and associated hardware are supplied with the directional coupler. Torque the center conductor bolt to 292 in-lbs (32.7 N-m). For wiring and connector mating assistance, refer to [Section 4.3, "Wiring/Connector lists"](#) on page 4.3.1.
  7. Close and secure the exciter panel. Turn on (enable) the ac power source.
  8. Using the front panel UI, go to the User Settings -> RF Monitor -> RF Mon Select menu and select Reflected Power. Use a digital multimeter to measure the RMS voltage on the control/interface PWB's RF MONITOR BNC connector (J1).
    - ❖ If the measurement is less than 156 mV RMS, no further adjustment is required. Proceed to [Step 10](#).
    - ❖ If the measurement is greater than 156 mV RMS, you will need to null the directional coupler as detailed in [Step 9](#).
  9. If necessary, null the directional coupler as follows:
    - ❖ Turn off (disable) the ac power source. Disconnect the transmitter from the antenna system and connect the transmitter's RF output to a suitably rated 50-ohm test load.
    - ❖ Remove the 0.5-inch diameter black hole-plug from the exciter panel, noting it is located above the upper, right-hand corner of the control/interface PWB (A4). **NOTE:** This allows access to the directional coupler's variable resistor.
    - ❖ Turn on (enable) the ac power source. Set the forward power to 1.6 kW and press RF On.
    - ❖ Connect an oscilloscope to the reflected power sample test point (TP24) on the control/interface PWB (A4). Use a tuning tool or insulated screwdriver (available for purchase from Nautel, Part # HAS48) to adjust the directional coupler's variable resistor, through the hole in the exciter panel, to achieve the lowest possible rms voltage on the oscilloscope. If you cannot achieve 156 mV or less, contact Nautel.
    - ❖ Re-install the hole plug in the exciter panel. Close the front door.
    - ❖ Press RF Off and turn off (disable) the ac power source.
    - ❖ Reconnect the transmitter's RF output to the antenna system.
  10. Turn on (enable) the ac power source and press RF On. Ensure the offending alarm has cleared.



## Arc Detector UV Sensor Replacement

**WARNING! LETHAL VOLTAGES EXIST INSIDE THE TRANSMITTER WHEN THE POWER IS TURNED ON. TURN OFF AND LOCK OUT THE POWER AT THE SOURCE AND WAIT UNTIL THE THREE AMBER LEDS IN THE BACK OF THE TRANSMITTER ARE OFF BEFORE REMOVING CONNECTIONS OR ASSEMBLIES.**

Figure 4.1.28: Location of Arc Detector Assembly

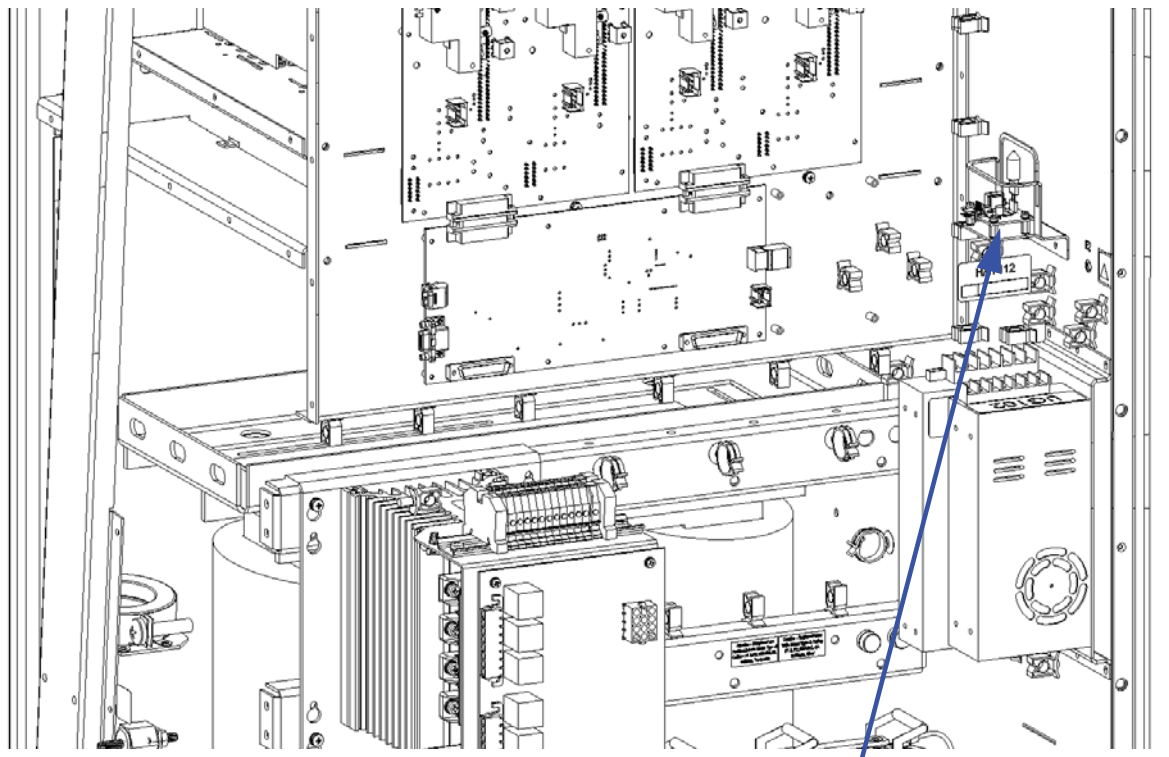

Partial Rear View; Rear Door and Side Panel Removed for Clarity

**Arc Detector Assembly (A24)**

1. Turn off (disable and lock out) the ac power at the source. When the three ac indicator LEDs are off (amber when on), open the rear door. Verify the three dc indicator LEDs on each power module interface PWB are off (amber when on). For additional safety, measure the dc voltage across the + and - terminals of any of the four, electrolytic capacitors. Open the lower, front panel to access the power transformer's terminals and measure all line-to-line and line-to-neutral ac voltages. There should be little or no ac or dc voltage. **DO NOT PROCEED** if the dc voltage is greater than 5 V.
2. Disconnect the cable attached to the arc detector assembly (see [Figure 4.1.28](#)), taking note of the connector label on the cable and the assembly.

3. Carefully remove and retain the two (2) sets of mounting hardware and remove the arc detector assembly from the transmitter. Remove the UV sensor (U2) from the arc detector assembly's driver PWB (U1) (see [Figure 4.1.29 on page 4.1.91](#)).
4. Obtain a replacement UV sensor (Nautel Part # UB89).

**WARNING! TAKE SPECIAL CARE WHEN HANDLING THE UV SENSOR AFTER REMOVING IT FROM THE PACKAGING SO IT DOES NOT RECEIVE IMPACT SHOCK. DO NOT ALLOW SKIN CONTACT WITH THE GLASS FACE. WEAR CLEAN GLOVES TO ENSURE NO OILS FROM YOUR SKIN CONTACT THE SURFACE OF THE GLASS.**

5. Cut the anode lead of the UV sensor to the same length as the cathode, noting the anode/cathode orientation and taking care not to bend the leads. Install the UV sensor on the arc detector assembly's driver PWB (U1), ensuring proper orientation (see [Figure 4.1.29 on page 4.1.91](#) and [Figure 4.1.30 on page 4.1.91](#)).
6. Complete the replacement procedure by reversing [Step 2](#) and [Step 3](#).
7. Re-install the lower, front panel over the power transformer. Close and secure the rear door. Turn on (enable) the ac power source and resume transmitter operation. Ensure the offending alarm has cleared.

Figure 4.1.29: Arc Detector Assembly UV Photo Tube Sensor (UB89)

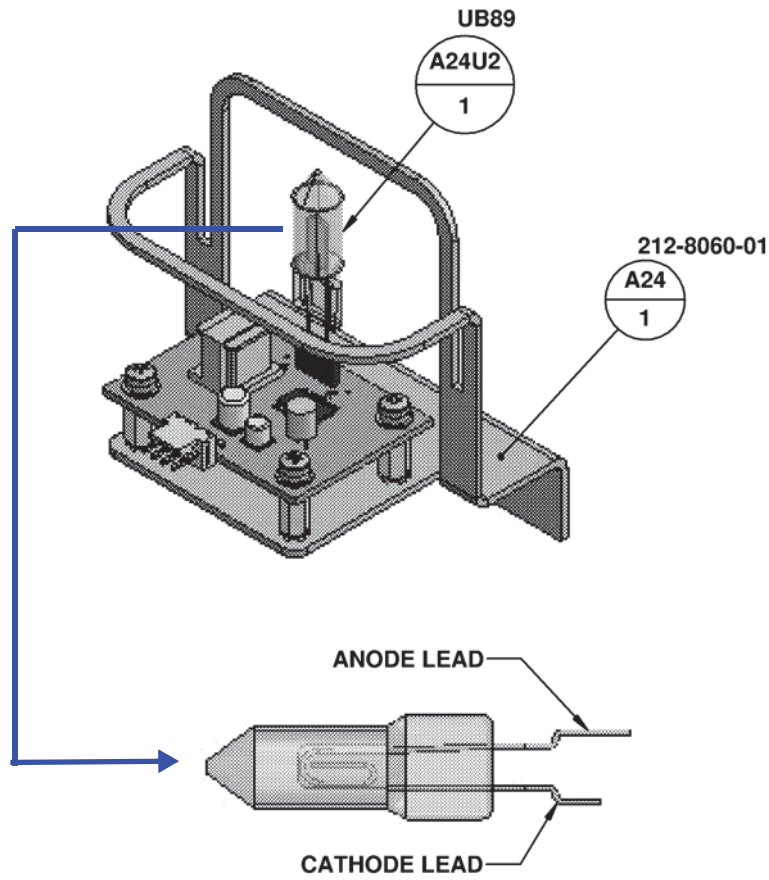
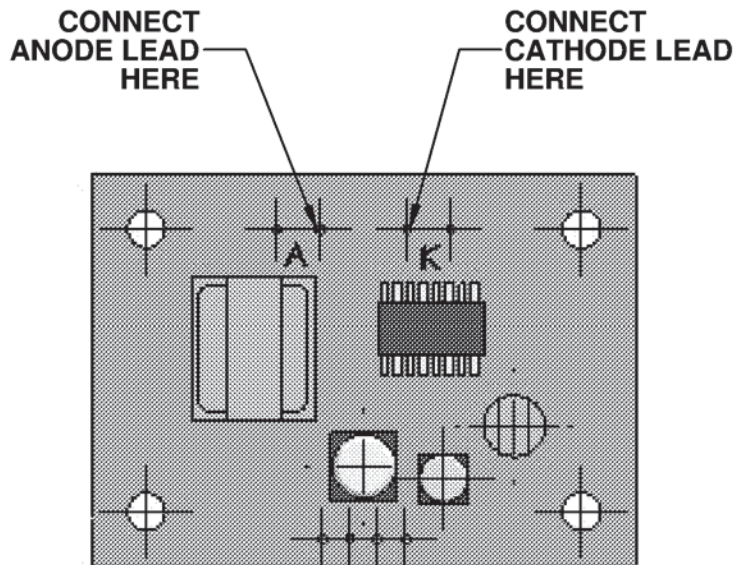

Figure 4.1.30: UB89 Orientation on Driver PWB U1



## +15 V or +48 V Power Supply Replacement

**WARNING! LETHAL VOLTAGES EXIST INSIDE THE TRANSMITTER WHEN THE POWER IS TURNED ON. TURN OFF AND LOCK OUT THE POWER AT THE SOURCE AND WAIT UNTIL THE THREE AMBER LEDS IN THE BACK OF THE TRANSMITTER ARE OFF BEFORE REMOVING CONNECTIONS OR ASSEMBLIES.**

Figure 4.1.31: Location of +15 V and +48 V Low Voltage Power Supplies

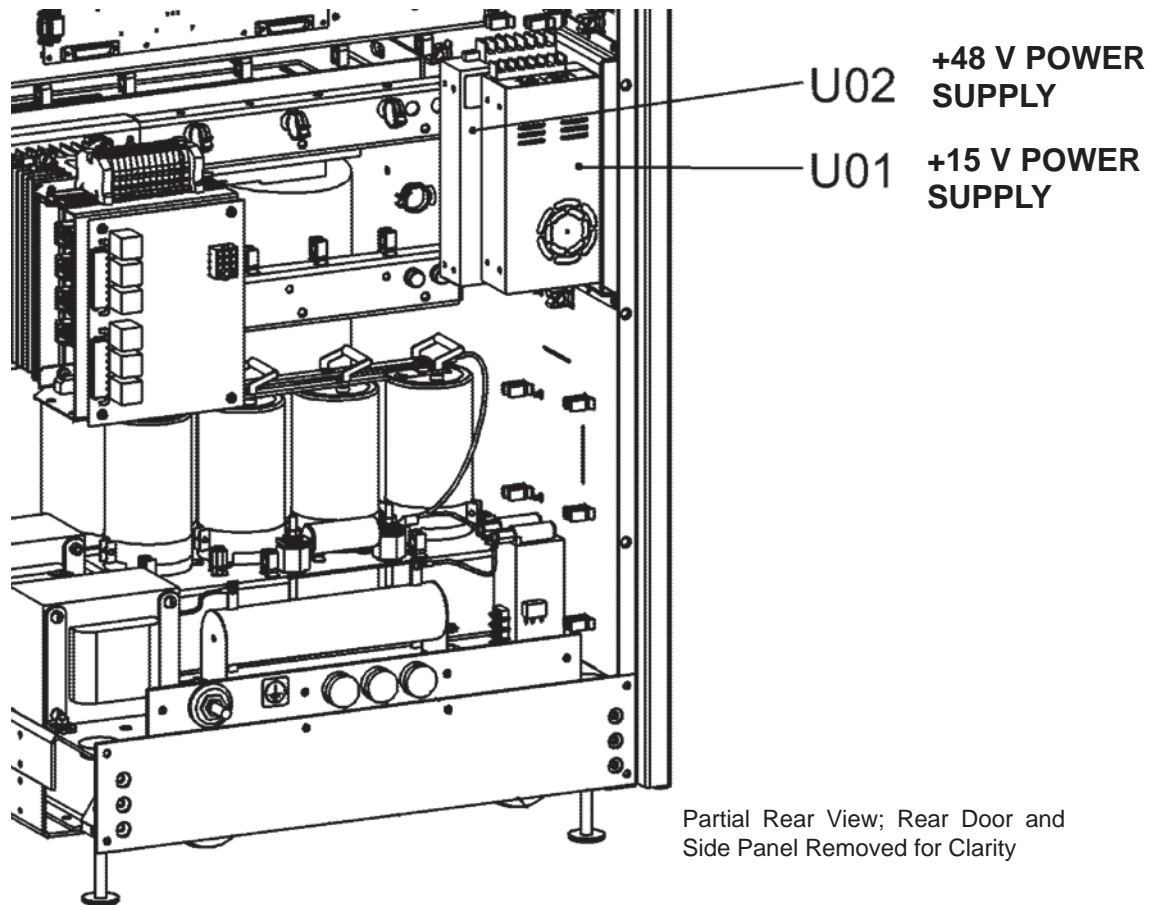

**NOTE:** Both the +15 V (U1) and +48 V (U2) power supply modules must be removed to allow the replacement of either module.

- 
1. Turn off (disable and lock out) the ac power at the source. When the three ac indicator LEDs are off (amber when on), open the rear door. Verify the three dc indicator LEDs on each power module interface PWB are off (amber when on). For additional safety, measure the dc voltage across the + and - terminals of any of the four, electrolytic capacitors. Open the lower, front panel to access the power transformer's terminals and measure all line-to-line and line-to-neutral ac voltages. There should be little or no ac or dc voltage. **DO NOT PROCEED** if the dc voltage is greater than 5 V.
  2. Disconnect all wiring attached to the +15 V power supply module (U1) and +48 V power supply module (U2) (see [Figure 4.1.31 on page 4.1.92](#)), taking note of the wiring labels.
  3. Carefully remove and retain the six (6) sets of mounting hardware that secure the power supply mounting bracket to the transmitter. Remove the screws that secure the suspect power supply to the mounting bracket.
  4. Obtain a replacement power supply module, noting:
    - ❖ the +15 V power supply module is Nautel Part # UG102
    - ❖ the +48 V power supply module is Nautel Part # UG103
  5. Install the new power supply module by reversing [Step 2](#) and [Step 3](#). Ensure all connections are tight, noting there are special torque requirements for the L, N, G, V+ and V- terminals for each supply.
    - ❖ For the +15 V power supply module, torque the wiring connections to 9.7 in-lbs (1.1 N-m).
    - ❖ For the +48 V power supply module, torque the L, N and G wiring connections to 15 in-lbs (1.7 N-m) and torque the V+ and V- connections to 16 in-lbs (1.8 N-m)..
  6. Re-install the lower, front panel over the power transformer. Close and secure the rear door. Turn on (enable) the ac power source and resume transmitter operation. Ensure the offending alarm has cleared.

## Graphic User Interface Display and UI Interface PWB Replacement

### Graphic User Interface (GUI) Display Replacement

See [Figure 4.1.32](#).

1. Turn off (disable) the ac power source for the transmitter.
2. Open the front door to access the GUI display (U3) on the back of the door.
3. Disconnect the cable attached to the GUI display, noting its orientation.
4. Carefully remove the four (4) sets of mounting hardware that secure the GUI display and remove the GUI display from the transmitter.
5. Obtain a replacement GUI display (Nautel Part # UW146).
6. Reverse [Step 3](#) through [Step 4](#) to reinstall the GUI display. Reconnect all wiring.
7. Turn on (enable) the ac power source for the transmitter.

Figure 4.1.32: Graphic User Interface and UI Interface PWB Location

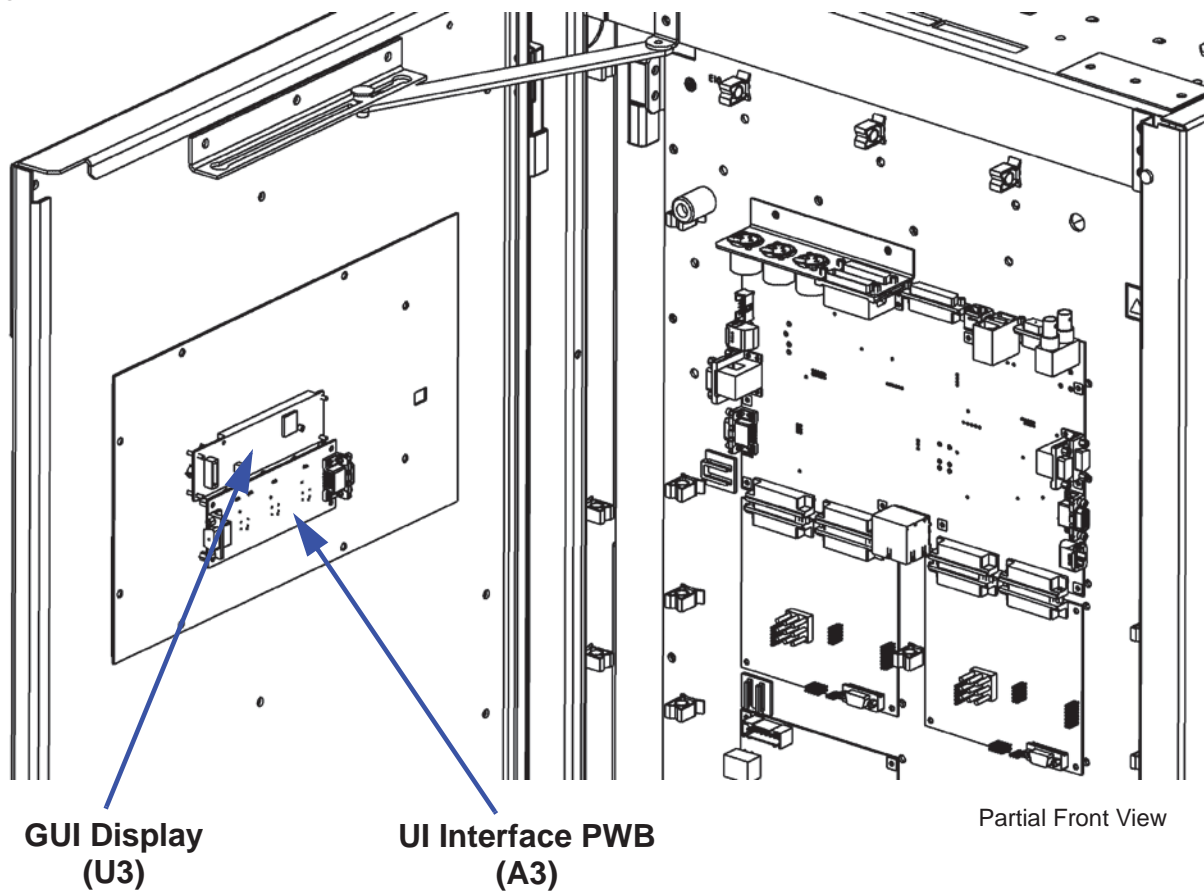

## UI Interface PWB Replacement

See [Figure 4.1.32](#).

1. Turn off (disable) the ac power at the source.
2. Open the front door to access the UI interface PWB (A3) on the back of the door.
3. Disconnect the cables attached to the UI interface PWB, noting their orientation.
4. Remove and retain the four (4) M4 mounting screws that secure the PWB and remove the PWB from the transmitter.
5. Obtain a replacement UI interface PWB (Nautel Part # NAPI142A).
6. Reverse [Step 3](#) and [Step 4](#) to reinstall the GUI display. Reconnect all wiring.
7. Turn on (enable) the ac power source and resume transmitter operation.