

# NX200 TRANSMITTER

## PRE-INSTALLATION MANUAL

Document: NHB-NX200-PRE

Issue: 3.0 2012-11-01

Status: Standard





**Nautel Limited**

10089 Peggy's Cove Road  
Hackett's Cove, NS Canada B3Z 3J4  
Phone: +1.902.823.3900 or  
Toll Free: +1.877.6NAUTEL (6628835) (Canada & USA only)  
Fax: +1.902.823.3183

**Nautel Inc.**

201 Target Industrial Circle  
Bangor, Maine USA 04401  
Phone: +1.207.947.8200  
Fax: +1.207.947.3693

**Customer Service (24 hour support)**

+1.877.628.8353 (Canada & USA only)  
+1.902.823.5100 (International)

Email: [support@nautel.com](mailto:support@nautel.com)

Web: [www.nautel.com](http://www.nautel.com)

The comparisons and other information provided in this document have been prepared in good faith based on publicly available information. The reader is encouraged to consult the respective manufacturer's most recent published data for verification.

© Copyright 2012 NAUTEL. All rights reserved.



---

# CONTENTS

---

---

RELEASE CONTROL RECORD	IX
------------------------	----

---

ABOUT THIS MANUAL	XI
-------------------	----

---

ABOUT SAFETY	XV
Electrical Hazards	1-xv
Lightning Hazards	1-xvi
RF Hazards	1-xvi
Toxic Hazards	1-xvi
Other Hazards	1-xvi

---

SAFETY PRECAUTIONS	XVII
Personal Safety	1-xvii
Site Safety	1-xviii
Equipment Safety	1-xx

---

DECLARATION OF CONFORMITY	XXIII
---------------------------	-------

---

DESCRIPTION	1-1
Capabilities	1-1
Options	1-2

---

PRE-INSTALLATION TASKS	2-1
Preparing for installation	2-1
Selecting a location for the transmitter	2-3
Installing an antenna feedline	2-3

---

---

<b>PHYSICAL REQUIREMENTS</b>	<b>3-1</b>
Dimensions	3-1
Clearances	3-2
Weight	3-9
<hr/>	
<b>COOLING REQUIREMENTS</b>	<b>4-1</b>
Air flow in the transmitter	4-1
Cooling	4-3
Heating	4-9
<hr/>	
<b>ELECTRICAL REQUIREMENTS</b>	<b>5-1</b>
Electrical power	5-1
Station reference ground	5-9
<hr/>	
<b>RF OUTPUT REQUIREMENTS</b>	<b>6-1</b>
Antenna feed cable	6-1
Antenna system	6-3
<hr/>	
<b>PLANNING AUDIO INPUTS</b>	<b>7-1</b>
Analog inputs	7-1
Digital inputs	7-2
Other features	7-3
<hr/>	
<b>PLANNING CONTROL/MONITOR CONNECTIONS</b>	<b>8-1</b>
AUI control	8-1
Digital inputs	8-1
Digital outputs	8-7
Analog outputs	8-10
Web based control	8-11
External interlock	8-11
PDM inhibit	8-11

---

---

<b>PARTS AND TOOLS</b>	<b>9-1</b>
Contacting Nautel	9-1
Parts supplied by Nautel	9-1
Parts not supplied by Nautel	9-2
Parts ordering	9-2
Module replacement program	9-2
Tools for installation	9-3

---

<b>PRE-INSTALLATION ASSISTANCE</b>	<b>10-1</b>
Pre-installation consulting	10-1
Installation and commissioning service	10-1
Online documentation	10-2
On-site support	10-3
Training	10-3
Extended warranties	10-4

---

<b>LIST OF TERMS</b>	<b>11-1</b>
----------------------	-------------





# RELEASE CONTROL RECORD

Issue	Date	Reason
3.0	2012-11-01	Release 3 of product (NARA57A)



## ABOUT THIS MANUAL

This manual provides information about preparing for the delivery and installation of an NX200 transmitter. This manual is intended for use by field technicians, site managers, and installation planners.

---

## USING THIS MANUAL

Read the task list provided in [Section 2, “Pre-installation tasks” on page 2-1](#). The task list describes the preparations you must make prior to receiving and installing the NX200 transmitter.

Later sections of the manual provide reference information regarding physical, cooling, electrical, and antenna requirements.

---

## TECHNICAL SUPPORT

Nautel offers technical support to customers over the Internet and by telephone. Nautel’s customer support team will answer your questions and work with you to identify and resolve problems.

For 24-hour technical support, call toll free at 1.877.628.8353 (in USA and Canada only) or call 1.902.823.5100 (international) or find us on the Internet at <http://www.nautel.com>.

For parts and tools information, see [“Parts and tools” on page 9-1](#) of the *NX200 Pre-Installation Manual*.

For extended warranty information, see [“Pre-installation assistance” on page 10-1](#) of the *NX200 Pre-Installation Manual*.

## NX200 TRANSMITTER MANUALS

The NX200 documentation suite includes the following documents:

**NX200 PRE-INSTALLATION MANUAL, NX200-PREINST.** Provides instructions and reference information needed when planning and preparing for the installation of an NX200 transmitter.

**NAUTEL SITE PROTECTION MANUAL.** Provides detailed information about protecting your site from lightning-related hazards.

**NX200 INSTALLATION MANUAL, NX200-INST.** Provides instructions and reference information needed when installing an NX200 transmitter.

**NX200 OPERATING AND MAINTENANCE MANUAL, NX200-OPS-MAINT.** Provides instructions for operating, maintaining and troubleshooting an NX200 transmitter. It also provides reference information needed when performing diagnostic procedures.

**NX200 TROUBLESHOOTING MANUAL, NX200-TROUBLE.** Provides detailed technical information about the NX200 transmitter, including electrical schematics and mechanical drawings.

---

## NAUTEL WEBSITE / ONLINE RESOURCES

The Nautel website provides useful resources to keep you up to date on your NX200.

### NAUTEL USER GROUP (NUG)

The website includes a special section that customers can log into in order to access the Nautel customer newsletter, product manuals, frequently asked questions (FAQ), information sheets, quick guides and information about field upgrades.

**Figure 3.1: Accessing the NUG**

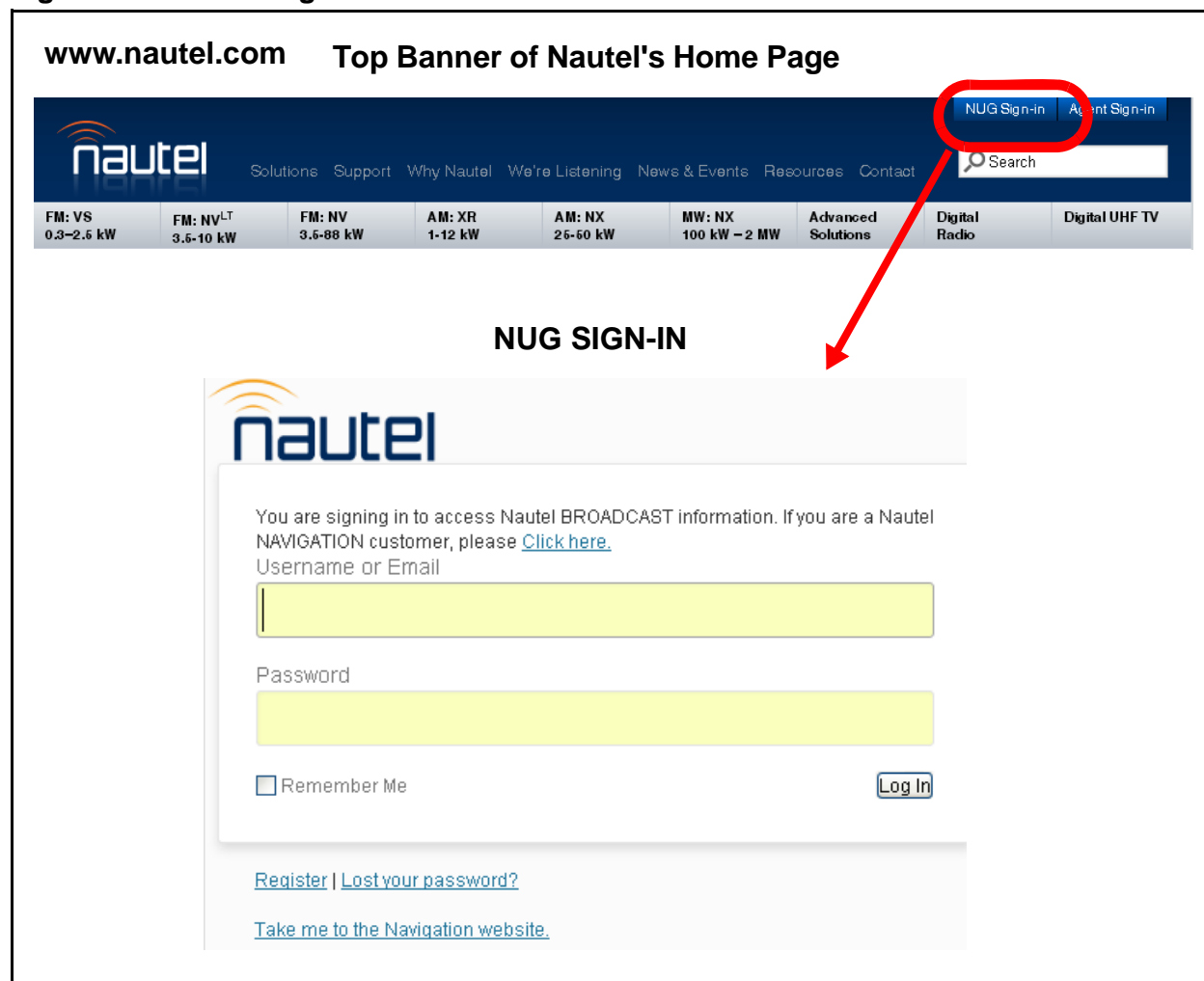

## DOCUMENTATION: ONLINE AND PRINTED

The website's NUG section provides online access to all the documentation for your NX200. Documentation is provided in Acrobat (PDF) format. You can use the documentation online or print the sections that you need.

### When using online documents:

- Click on the blue hyperlinks to jump to a related section, or to get additional information (e.g., view a term's definition).
- To search a document to find keywords, use **Find** in Acrobat Reader's **Edit** menu.
- To quickly find a specific section, click the section in the PDF file's **Bookmarks** list.

When using printed documents:

- To find keywords, go to the *Index* section at the end of the manual.
- To find a specific term, go to the *List of Terms* section near the end of the manual.

## About Safety

All Nautel transmitters are designed to meet the requirements of EN60215, Safety Requirements for Radio Transmitters. The philosophy of EN60215 is that the removal of any cover or panel that can only be opened using a tool is a maintenance activity, and that any person performing a maintenance activity is expected to be trained for that activity. Under EN60215, it is assumed that trained personnel will be knowledgeable and will take precautions such as removing all power to the transmitter before accessing its components.

## Electrical Hazards

To remove power from the transmitter, switch off and lock out the ac power. There are three amber LEDs at the bottom rear of the cabinet that glow to remind anyone who has not turned off the power that the system is live and serious danger is present.

### DANGER - HIGH VOLTAGE



Indicates dangerous voltage (in excess of 72 volts), capable of causing a fatal electrical shock, are present on or near parts bearing this label.

**WARNING: IT IS NOT ENOUGH TO SWITCH OFF RF POWER. THE POWER LINE IS STILL CONNECTED. DISCONNECT AND LOCK OUT THE UPSTREAM SUPPLY BEFORE SERVICING.**

Mount the transmitter ac power disconnect switch/breaker close to the transmitter so that it can be reached quickly in an emergency. Clearly label the switch/breaker (e.g., EMERGENCY SWITCH).

After turning off the power, always perform a measurement to confirm that the power is off before touching anything within the transmitter. If the wrong breaker was opened, the equipment will be live.

**WARNING: DO NOT USE AN ORDINARY MULTIMETER TO CHECK FOR VOLTAGE, SINCE IT MAY HAVE BEEN LEFT INADVERTENTLY ON THE AMP (A) RANGE, TRIGGERING A SHORT AND AN ARC BLAST THAT COULD RESULT IN SEVERE BURNS AND EVEN DEATH.**

Use only a non-contact voltage probe or a safety voltmeter (available from vendors such as Fluke, Ideal, and Teagam).

Use a proper lockout procedure to ensure that another worker cannot accidentally reapply power while you are performing maintenance on any part of the transmitter or site.

## **Lightning Hazards**

Before opening the transmitter and touching internal parts, remove and solidly ground the antenna connection.

**WARNING: IT IS NOT ENOUGH TO GROUND THE ANTENNA TERMINAL WITH THE ANTENNA STILL CONNECTED. EVEN A SMALL IMPEDANCE IN THE GROUND STRAP WILL RESULT IN LETHAL VOLTAGES DURING A LIGHTNING STRIKE.**

## **RF Hazards**

A serious RF hazard and very high voltages exist in the vicinity of the antenna and its networks during normal operations.

## **Toxic Hazards**

There are devices used in this equipment containing beryllium oxide ceramic, which is non-hazardous during normal device operation and under normal device failure conditions. These devices are specifically identified with "(BeO)" in the Description column of the Troubleshooting Manual's parts list(s).

Do not cut, crush or grind devices because the resulting dust may be hazardous if inhaled. Unserviceable devices should be disposed of as harmful waste.

## **Other Hazards**

Ensure that appropriate fire alarms and fire extinguishers are available. Extinguishers must be suitable for use on electrical fires.

Many other site safety risks exist. It is beyond the scope of this manual to identify all the risks and procedures.



## **Safety Precautions**

This section provides very important information about protecting the safety of personnel and equipment:

- [Personal Safety - see page xvii](#)
- [Site Safety - see page xviii](#)
- [Equipment Safety - see page xx](#)

### **Personal Safety**

#### **Training**

The training of any personnel who will have physical access to the site or the transmitter is very important. Personnel must be familiar with the transmitter, so that they can avoid physical danger, and be aware of hazards to themselves and the equipment.

Nautel offers a number of training courses covering the basic fundamentals of RF systems and transmitters, and the operation and maintenance of the transmitter. For more information about available courses and schedules, go to the Nautel website at <http://www.nautel.com/Training.aspx>, or ask your Nautel sales representative.

#### **Site Orientation**

When you give personnel access to the transmitter site (e.g., hiring new personnel, or giving access keys to personnel), perform a site orientation to ensure that they are familiar with the site, on-site procedures, and on-site hazards. Cover the following topics:

- Securing the site (locking doors and fences) to prevent unauthorized access
- How and when to call for technical support or emergency assistance
- Areas of the site and pieces of equipment that are off limits

### **Voltage Awareness**

Ensure that all personnel that are able to access areas with high voltage circuits or high field strengths are aware of the hazards associated with high voltage. Cover the following topics:

- High voltage or high field strength areas where caution is required
- Physical risks of electric shock
- Risks for personnel with pacemakers or other medical implants
- Induced voltages in high field strength areas
- On-site risks during thunderstorms and lightning strikes
- Operation of safety interlocks (if installed)

### **First Aid**

Nautel does not offer first aid training, since the hazards associated with high voltage and RF energy are not specific to the transmitter. However, the customer should provide first aid training to all personnel who have access to the transmitter site. First aid training should include CPR, care of burns, artificial respiration, and defibrillation if specific equipment is available on-site.

## **Site Safety**

### **Controlling Access**

Transmitters and antennas generate and carry dangerous voltages that can be harmful or fatal. It is very important that you control access to the site and its equipment. To secure your transmitter site, use:

- Locking steel or security doors to prevent casual access
- A perimeter fence to keep trespassers away from the antenna system and feedline
- "No Trespassing" signs
- An alarm system

## **Marking Hazards**

Place warning signs close to any hazardous areas or systems (e.g., the feedline or the antenna system). Make the signs large enough that they cannot be missed. Provide signage in all languages used in the region. These signs are intended not only for authorized personnel, but also for emergency responders or accidental trespassers.

## **Qualifying Site Personnel**

Make sure that personnel who have access to the site are qualified to work around electronics and high voltage systems.

## **Ac Power Protection**

You should take steps to protect equipment from surges (over-voltage spikes) on the ac power lines. Surges may occur during thunderstorms, or because of malfunctions in the electrical distribution grid. Surge suppressors and ac power conditioners can prevent serious damage to your on-site equipment, including the transmitter.

## **RF Protection**

Transmitters and their antenna systems create intense radio frequency fields at the transmitter site, particularly near the feedline, antenna and tower. At some sites, these fields may cause biological effects, including the heating of body tissues. Intense fields can also create dangerous high voltages on ungrounded, conductive surfaces and objects. At certain points where high voltage conductors come close to grounded conductors (e.g., at feedline junctions or on the tower), dangerous electrical arcing or overs can occur. It is very important that you take the following steps to prevent damage to equipment or personnel due to RF fields:

- Use safety interlocks to de-energize transmitters if personnel open doors or panels accessing high field areas
- Place warning signs in any locations where high fields can occur
- Train personnel about the short-term and long-term hazards of RF radiation
- Physically block access to the area around the antenna system, feedline and tower
- Ground all exposed conductive surfaces or objects in high field areas

The RF connection to the transmitter output can be a serious safety hazard. Connect a 50  $\Omega$  test load during installation and commissioning. It is recommended that a switch be used to automatically connect the transmitter to the antenna system without human contact with the transmitting conductors.

### **Safety Interlocks**

The transmitter contains an electrical interlock, which is an external circuit that turns off the RF output if any of its switches are opened.

### **Ac Disconnect Switch**

Safe operation of the transmitter requires an ac disconnect switch. Lock the ac disconnect switch in the disconnected (open) position during the installation process.

## **Equipment Safety**

### **Electrostatic Protection**

The transmitter's systems are very rugged and resistant to damage. However, it is possible for damage to occur because of high voltage electrostatic discharges during servicing. Train all service personnel to ground themselves to bleed off any static charge before opening the transmitter or touching any exposed components. Provide a grounding wand or known ground (e.g., a grounded metal table) that personnel can use to discharge themselves.

### **Surge Protection**

Surge protection is recommended for your entire site. However, even if you do not use a surge protector on the service entrance to the site, you should install a surge protector in the transmitter's ac power feed to prevent over-voltage from entering the transmitter.

### **Lightning Protection**

The transmitter is designed to resist lightning strike damage. However, intense or repeated strikes could damage the transmitter. We recommend that you install lightning suppression on the antenna, tower and feedline to reduce the effect of lightning strikes on the transmitter itself (and to protect the rest of your site equipment and your personnel). For detailed information about lightning protection, see the Nautel Site Preparation Manual, available from your Nautel sales agent, or online from the Nautel website.

### **Physical Protection**

Consider physical hazards to equipment at your site, including the transmitter. Ensure that equipment is protected from weather (e.g., rain or flooding), even during extreme weather events. Place equipment so that it is not in the path of swinging doors or high-traffic areas. Do not allow wheeled items like office chairs or tables with wheels in the transmitter room, as these may damage equipment if accidentally pushed or knocked over. Do not place the transmitter under water pipes, drains, or sprinklers. Keep any equipment that generates heat, like the transmitter, away from flammable materials like ceiling panels, cubicle dividers, and curtains.

### **Earthquake Protection**

If the transmitter site is in a region that experiences any noticeable earthquake activity, take steps to prevent the transmitter from shifting or rocking during an earthquake. Even during minor earthquakes, rocking or movement of the transmitter is likely to damage the feedline connection, and could even cause a catastrophic failure of the ac power feed into the transmitter. During larger earthquakes, the weight of the transmitter chassis could be hazardous to nearby equipment or personnel.



## DECLARATION OF CONFORMITY

Hereby, Nautel Ltd. declares that this MF Broadcast Transmitter NX200 is in compliance with the essential requirements and other relevant provisions of Directive 1999/5/EC.

The subject equipment is intended for use in the following Member States (identified by ISO 3166 2-letter code):

AT	BE	CY	CZ
DK	EE	FI	FR
DE	GR	HU	IE
IT	LV	LT	LU
MT	NL	PL	PT
SK	SI	ES	SE
GB	IS	LI	NO
CH	BG	RO	TR

The use of this equipment requires a license in the above listed Member States.

The original Declaration of Conformity may be found on the Nautel Web site:

[www.nautel.com](http://www.nautel.com)

**CE0168!**





---

## SECTION 1: DESCRIPTION

This section provides a basic description of the NX200 transmitter and includes the following topics:

- [Capabilities](#)
- [Options - see page 1-2](#)

---

### CAPABILITIES

#### POWER

The NX200 is capable (with 120% positive peak modulation) of RF carrier power up to 220 kW. The maximum continuous average power (carrier plus modulation) is 300 kW.

The operator can vary the power continuously or switch to preset power levels using the NX200 graphic user interface (AUI). Presets store the power level, active exciter, and power scheduler status on a time-of-day and date basis. The power output can also be scheduled to correspond with authorized daytime power levels.

#### MODULATION

The NX200 is capable of double sideband (AM) modulation. With the addition of an optional internal signal generator, IBOC or DRM modulation can be provided to the exciter.

#### DUTY CYCLE

The NX200 will operate at nominal power with a 100% duty cycle – continuously – on an indefinite basis.

#### ANTENNA TOLERANCE

The NX200 will operate at rated power with a VSWR of up to 1.5:1. A higher VSWR results in a protective fallback of output power. The greater the VSWR, the greater the reduction in RF power. (To maintain the quality of digital broadcasts, lower VSWR levels are required. Consult with Nautel.)

The NX200 will not fail or completely shut down, regardless of antenna or feedline failure.

#### REMOTE CONTROL AND MONITORING

The NX200 remote control and monitoring options allow you to run a multiconductor signaling cable from the transmitter to a remote control board. This option lets you monitor all key parameters of transmitter operation, and control common functions, such as power output and exciter selection.

## REDUNDANCY

The NX200 features redundancy in all key systems:

- RF power modules
- Power supplies
- Exciters
- Cooling fans

## AC POWER

The NX200 variable power transformer can be set to use a range of input voltages and power frequencies, as described in the *NX200 Installation Manual*.

---

## OPTIONS

### IBOC

The NX200 supports IBOC digital radio as a modulation option. The external IBOC signal source provides a signal to the NX200 exciter.

### DRM

The NX200 supports Digital Radio Mondiale (DRM) radio as a modulation option. The external DRM signal source provides a signal to the NX200 exciter.

## SAFETY INTERLOCKS

Optional safety interlocks prevent unsafe access to the transmitter until the ac power is removed.

---

## SECTION 2: PRE-INSTALLATION TASKS

This section provides a list of tasks that you must perform prior to delivery and installation of the NX200 transmitter.



**WARNING: FAILURE TO COMPLY WITH RECOMMENDATIONS MAY VOID YOUR MANUFACTURER'S WARRANTY. FOR MORE INFORMATION, REVIEW YOUR WARRANTY DOCUMENTS.**

---

### PREPARING FOR INSTALLATION

To prepare for installation of an NX200 transmitter, perform the following tasks:

1. Ensure that the correct transmitter configuration is ordered. Check the ac power requirements, preset frequency, IBOC option, and other options.
2. Select a location for the transmitter in the transmitter room. Determine whether additional heating, ventilating or cooling capacity is needed at the site. Identify any special requirements regarding air flow around the cabinet (for example, ducting hot air away from the cabinet, or bringing in external cooling air). See [“Selecting a location for the transmitter” on page 2-3](#).
3. Ensure that interconnect wiring and associated cable tray system for use between the transformer and transmitter cabinets is ordered from Nautel or another suitable vendor.



*Note:*

*There are very specific requirements for the interconnect wiring and associated cable tray referenced in [Step 3](#). Suitable wiring, hardware and cable trays can be purchased from Nautel. It is highly recommended that you purchase these items from Nautel. If you decide to purchase these items from an alternate vendor, it is imperative that you read and understand the information presented in [Section 5, “Electrical requirements”](#). This section provides specific part information as well as insight into some of Nautel's design philosophy behind the interconnect wiring requirements.*

4. If this is an upgrade or replacement transmitter (that is, if the site is already set up for a transmitter), go to [Step 8](#). (If you are upgrading a site, verify the feedline, the lightning protection systems, and the ac power service. Refer to Nautel's *Recommendations for Transmitter Site Preparation Manual*.)
5. Install ac power service into the planned location of the transmitter, and select a location for the ac power disconnect switch near the transmitter location. For detailed information, see [“Electrical power” on page 5-1](#).

Be aware of lightning protection issues when installing ac power. Lightning protection is essential to protect both personnel and equipment at your site. Refer to Nautel's *Recommendations for Transmitter Site Preparation Manual*.

6. Install lightning protection on the antenna tower. Refer to Nautel's *Recommendations for Transmitter Site Preparation Manual*.
7. Place a work area with a clear table surface near the transmitter location. Provide electrostatic protection measures in the work area.
8. Order any accessories or optional equipment that you may need.
9. Terminate the transmitter end of the RF feedline with the appropriate mating connector. Unless otherwise specified in contract documents, the transmitter will accept a 6-1/8 inch EIA flange connector.
10. If the transmitter will be used to broadcast IBOC or DRM, perform a full impedance sweep of the antenna system. See ["Antenna system" on page 6-3](#).
11. Arrange manpower or lifting equipment to move and assemble the transmitter. You may want to use a forklift to move either the transmitter or its power transformer into place for installation.
12. Implement a safety interlock, if required. See the *NX200 Operations and Maintenance Manual* for details on using the optional keyed interlock system.
13. If you are going to use an external frequency reference, ensure that the reference source meets required specifications.
14. Prepare to integrate the NX200 transmitter into your station control circuitry, if required.
15. Train your station technicians and operators on the use and maintenance of the NX200 transmitter.

## SELECTING A LOCATION FOR THE TRANSMITTER

To ensure that the desired location for the NX200 transmitter is suitable, perform the following tasks:

1. Ensure that the floor area where the transmitter will be located is able to support the weight of the transmitter system.
2. Ensure the area above the transmitter and transformer cabinets is sufficient to install cable trays for the interconnect wiring between the transmitter and transformer. See [Section 5, “Electrical requirements”](#) for complete wiring details.
3. Measure the space to ensure that the transmitter will fit. See [Section 3, “Physical requirements”](#) for transmitter dimensions and clearances.
4. Ensure that transmitter room doors and the pathway of access from the receiving dock or building exterior to the installation location are large enough to accommodate the transmitter.

---

## INSTALLING AN ANTENNA FEEDLINE

When installing an antenna feedline for the NX200 transmitter, perform the following tasks:

1. Ensure that the RF feedline that will connect the transmitter and the antenna system has a suitably rated coaxial cable.
2. Connect the shield of the antenna feedline coaxial cable directly to the station reference ground where it enters the building. For more information about the station reference ground, see [“Station reference ground” on page 5-4](#).
3. Install lightning protection devices. For more information about lightning protection, refer to Nautel’s *Recommendations for Transmitter Site Preparation Manual*.
4. Pass the center conductor and the shield of the feedline cable through a ferrite toroid that is positioned between the shield ground at the building entrance and the shield termination at the transmitter. Install the ferrite toroid prior to installing flanges on the feedline cable.
  - To obtain the proper size ferrite toroid, contact Nautel support for recommendations (see [page 10-3](#)), or consult additional, outside suppliers.



---

## SECTION 3: PHYSICAL REQUIREMENTS

This section provides physical specifications for the NX200 transmitter and its components, and lists physical site requirements. This section includes the following topics:

- [Dimensions](#)
- [Clearances - see page 3-2](#)
- [Weight - see page 3-9](#)

---

### DIMENSIONS

The NX200 transmitter excluding power transformer cabinet and ac power entrance has the following dimensions:

- Height: 184.0 cm (72.4 in)
- Width: 191 cm (75.4 in)
- Depth: 120.8 cm (47.6 in)

**Figure 3.1: NX200 transmitter**

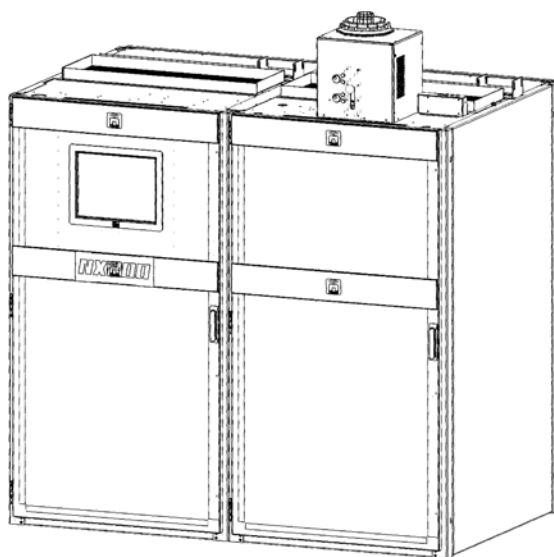

External power transformer cabinet (see Figure 3.6) and ac power entrance (see Figure 3.7) not shown

## CLEARANCES

For the transmitter cabinets, the required minimum clearances are 1.2 m (4.0 feet) at the front and rear to allow for the swing of the front and rear doors and 0.9 m (3.0 feet) at one side (either left or right) to allow for possible combiner maintenance.

Check the clearance to ensure that you will be able to open all doors and access panels. The front control panel is hinged on the left (when looking at the front of the transmitter).

Also consider access to the rear of the transmitter during installation and servicing, and access to the front of the transmitter during power module replacement. You must allow space to open the front panel and slide out any of the power modules. These modules slide straight in and out of the shelf unit in the front of the transmitter.



Figure 3.2: NX200 top view

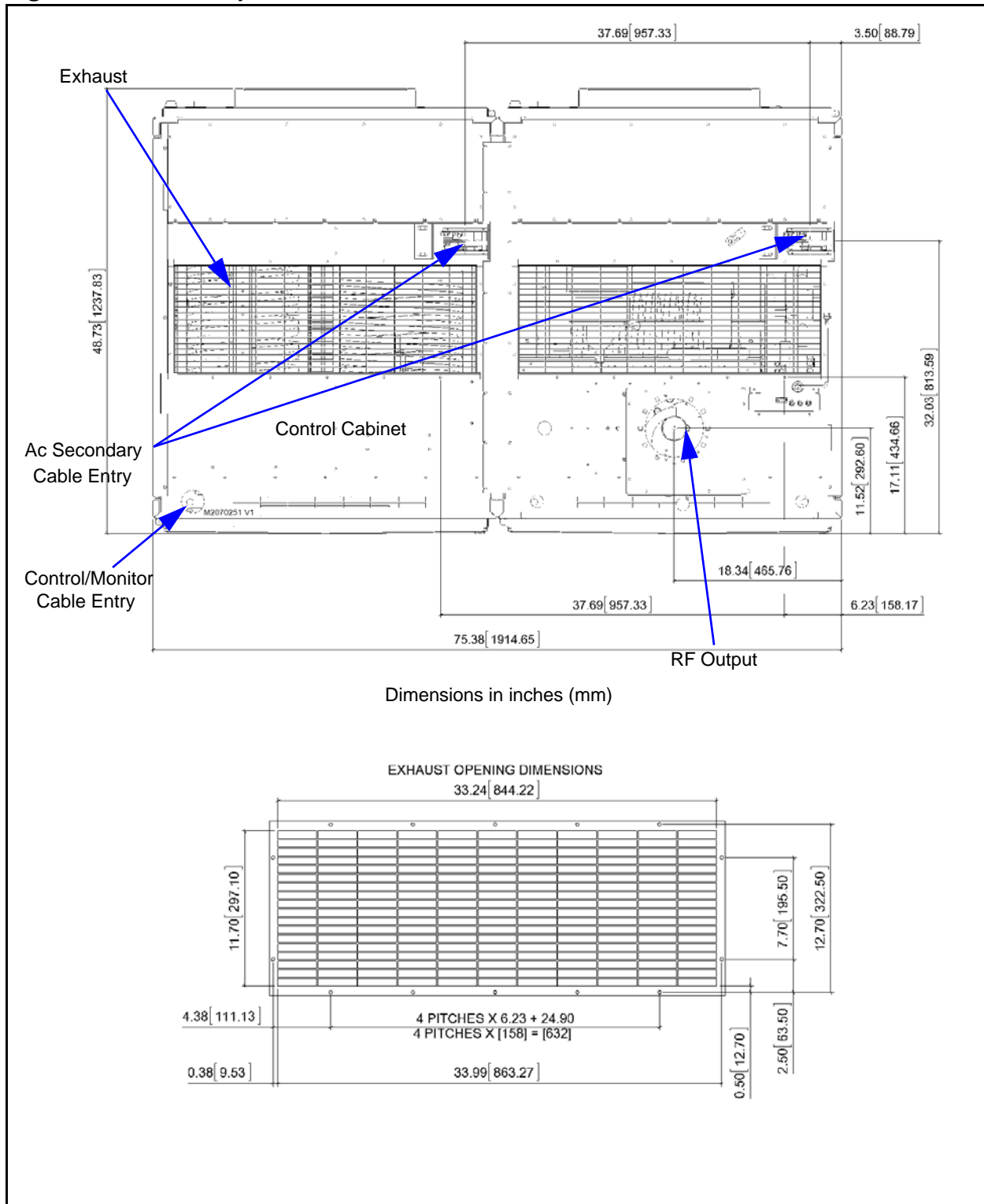

**Figure 3.3: NX200 top view (with door swing)**

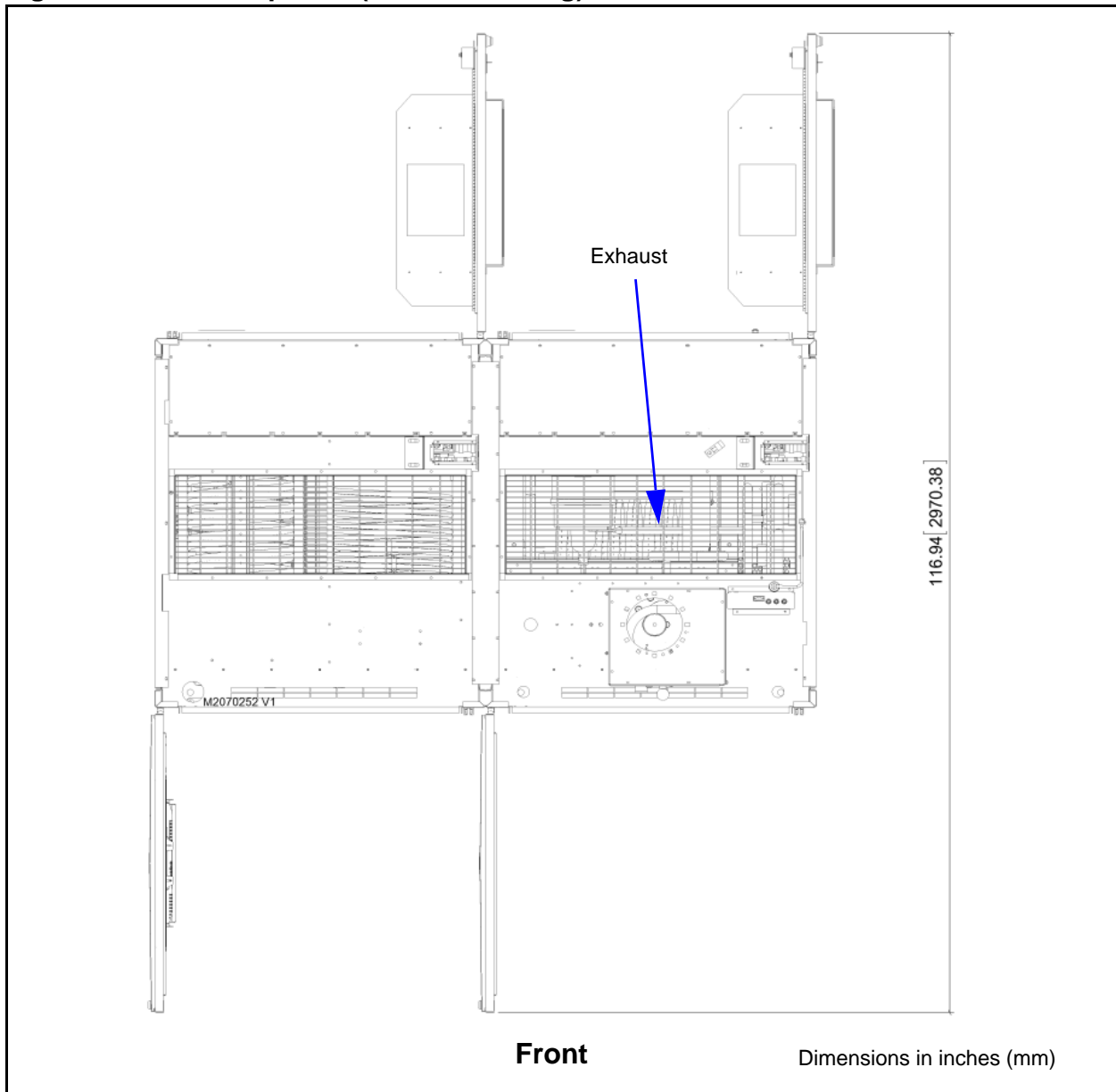

Figure 3.4: NX200 front view

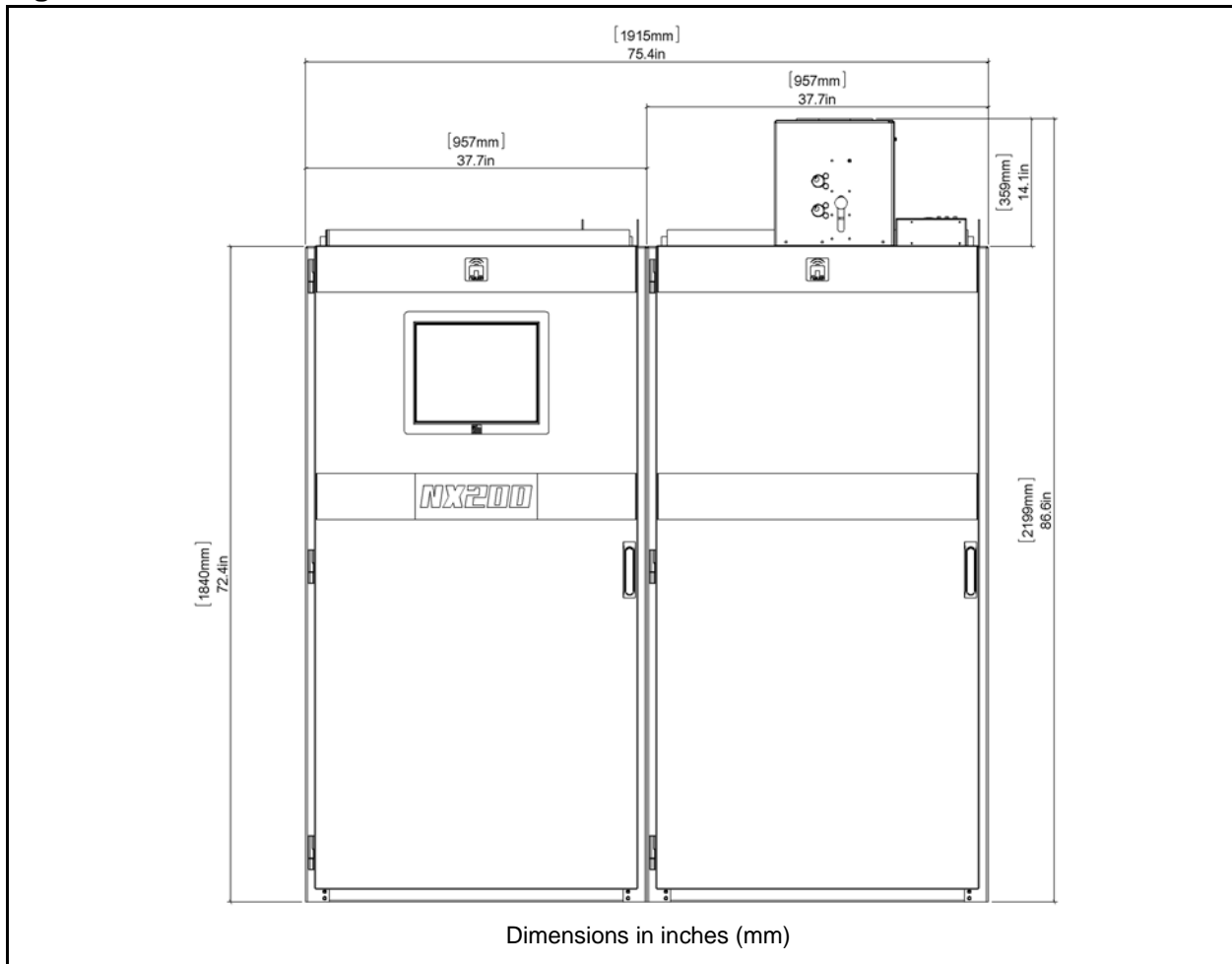
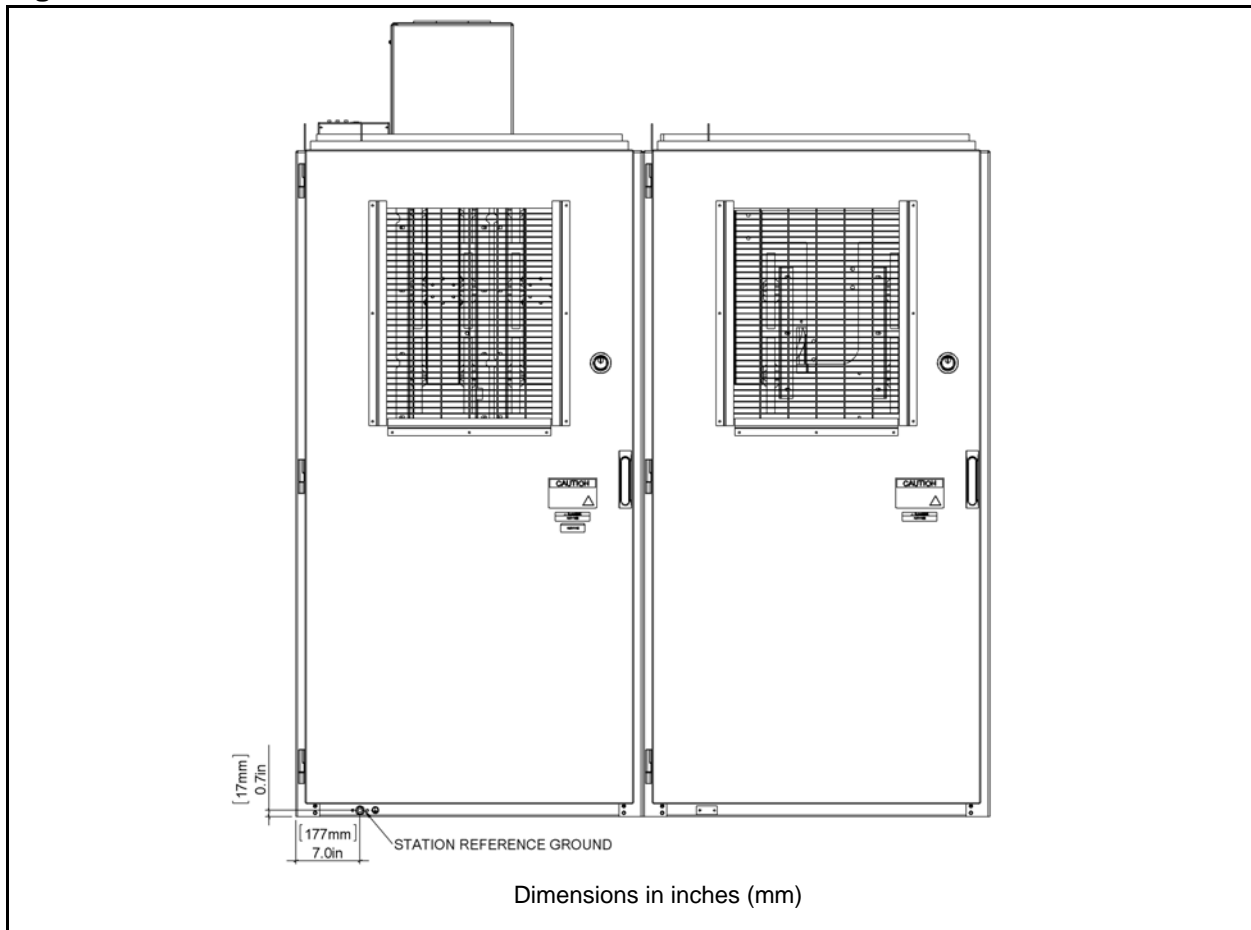
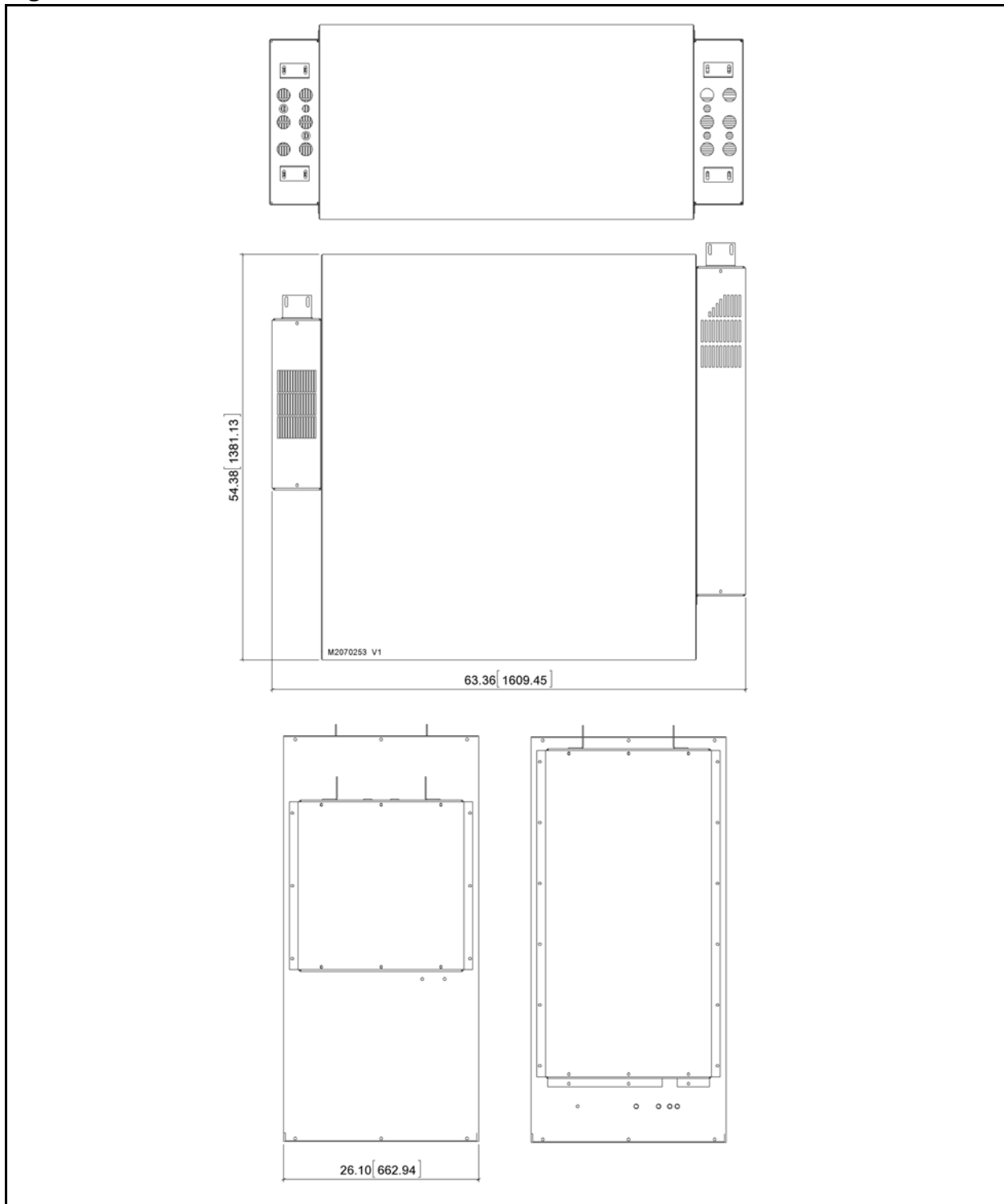

Figure 3.5: NX200 rear view



**Figure 3.6: NX200 External Power Transformer Cabinet**



**Figure 3.7: Ac power disconnect switch**

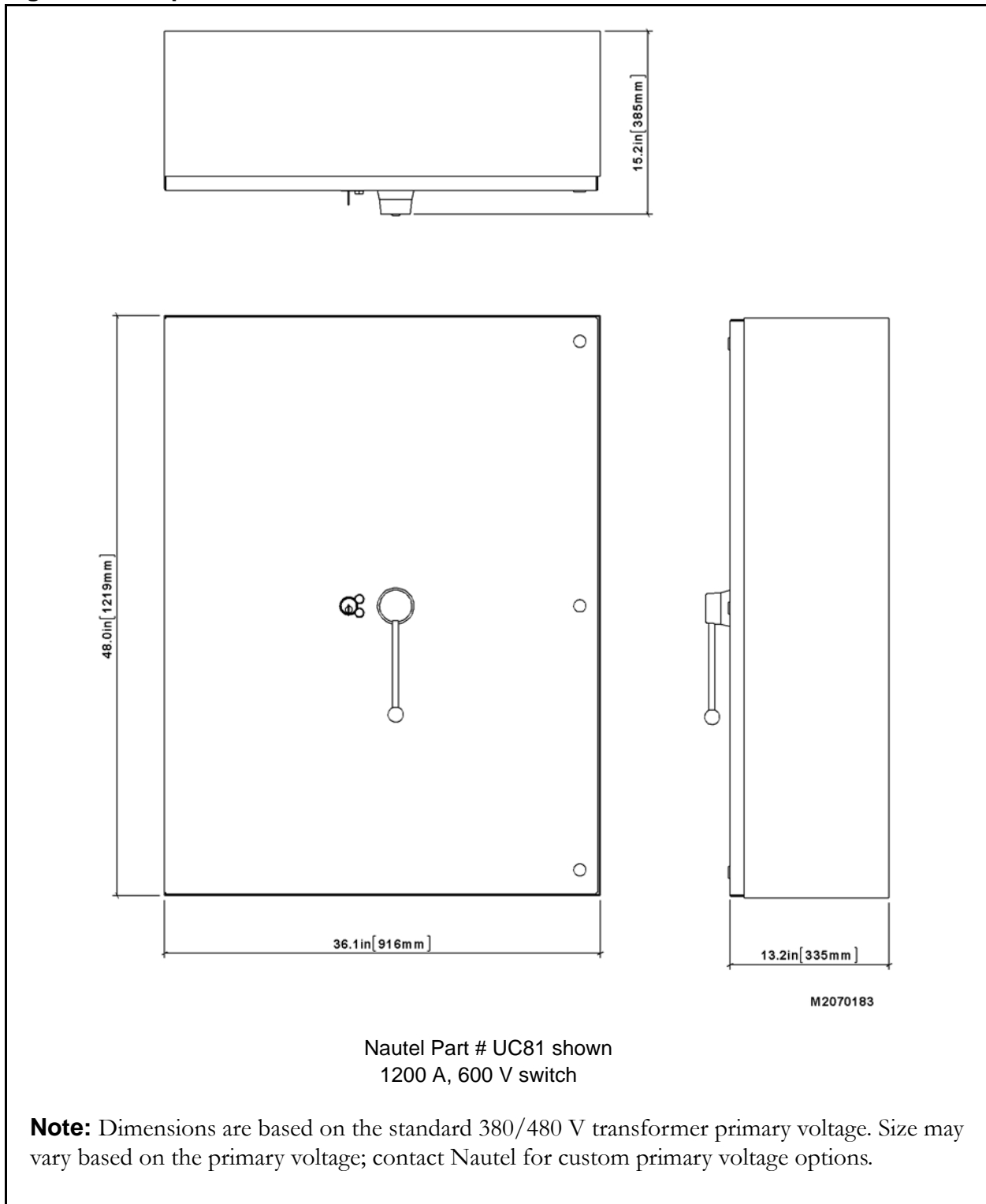

---

## WEIGHT

See [Table 3.1](#) for the various weights of transmitter components, including crated and uncrated weights.

**Table 3.1: Weight of components**

CRATE CONTENTS	UNCRATED WEIGHT	CRATED WEIGHT
Control cabinet Rack 1 (with modules)	567 kg (1250 lbs)	687 kg (1515 lbs)
Output cabinet, Rack 2 (with modules)	567 kg (1250 lbs)	687 kg (1515 lbs)
Power transformer cabinet	1178 kg (2597 lbs)	TBD kg (TBD lbs)
Ac power disconnect	372 kg (820 lbs)	TBD kg (TBD lbs)

**Note:** Weights are based on the standard 600 V transformer primary voltage. Weight may vary based on the primary voltage; contact Nautel for custom primary voltage options.





## SECTION 4: COOLING REQUIREMENTS

This section provides information about heating and cooling requirements for the NX200 transmitter site. Topics in this section include:

- [Air flow in the transmitter](#)
- [Cooling - see page 4-3](#)
- [Heating - see page 4-9](#)

### AIR FLOW IN THE TRANSMITTER

There are two configurations for drawing cooling air through the NX200 - open air cooling and closed air cooling. The NX200 has redundant cooling fans to aid each configuration in ensuring effective cooling.

#### OPEN AIR CONFIGURATION

In an open air configuration (see [Figure 4.1](#)), cooling air is drawn through air filters in the back of the transmitter. Air circulates down into the base of the transmitter, and is then pushed up through the front rack of the transmitter by a set of fans. Warm air exits the transmitter through the grill at the top. Exhaust air may or may not be ducted away from the transmitter. Cool air for the intake cannot be ducted to the transmitter as this would block access to the rear of the transmitter.

*Figure 4.1: Air flow in the NX200 transmitter (open air cooling shown)*

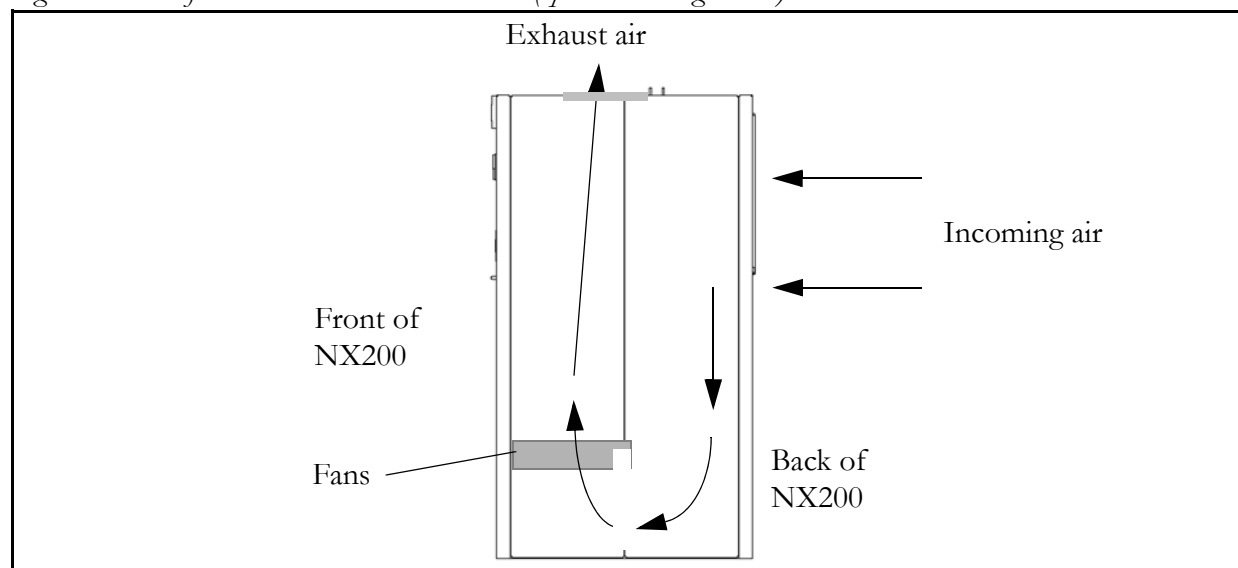

## CLOSED AIR CONFIGURATION

In a closed air configuration (see [Figure 4.2](#)), cool air is drawn in through a grill or duct at the top of the transmitter, near the back. The air circulates inside the transmitter and exhausts in the same manner as the open air cooling option. In this configuration, cooling air must be ducted to the intake grill and the exhaust air must be ducted away from the transmitter.

Closed air cooling requires an optional panel to cover the filter cut-out in the rear door. This panel is available from Nautel.

*Figure 4.2: Air Flow in the NX200 Transmitter (closed air cooling shown)*

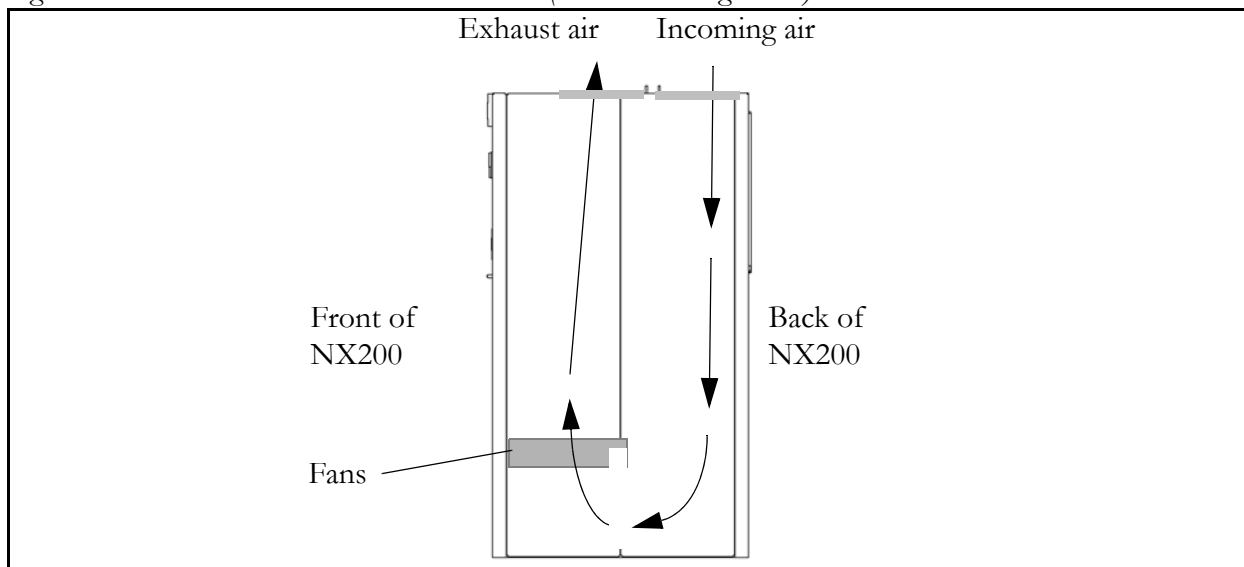

---

## COOLING

Do not allow the transmitter room ambient air temperature to exceed 50°C (122°F) at sea level. Cooler temperatures are recommended in order to improve the reliability of the transmitter. At higher altitudes, derate the maximum inlet air temperature as follows:

- De-rate the ambient temperature 3°C (5.4°F) per 500 m – or 2°C (3.6°F) per 1,000 feet – above sea level.

**Example:** At 1600 m (1 mile) above sea level, maximum ambient temperature should not exceed 40.4°C (104.7°F).

**Note:** Ensure hot air from the transmitter is not drawn back into the transmitter's cool air intake.

## COOLING PLANT REQUIREMENTS

In an NX200 system, heat is generated by both the transmitter and the transformer, and each may be cooled separately. The transmitter's efficiency is typically 92% and the transformer's efficiency is 98%. Calculate the power dissipated by the transmitter using the following equation:

$$P_{\text{loss (XMTR)}} = \left( \frac{1}{\eta_{\text{XMTR}}} - 1 \right) \bar{P}_{\text{out}}$$

Where  $\eta_{\text{XMTR}}$  is the transmitter's efficiency and  $\bar{P}_{\text{out}}$  is the transmitter's average output power. Calculate the power dissipated by the power transformer using the following equation:

$$P_{\text{loss (XFMR)}} = \left( \frac{1}{\eta_{\text{XFMR}}} - 1 \right) \frac{\bar{P}_{\text{out}}}{\eta_{\text{XMTR}}}$$

Where  $\eta_{\text{XFMR}}$  is the transformer's efficiency. For continuous tone modulation, calculate the average output power of the transmitter using the following equation:

$$\bar{P}_{\text{out}} = \left( 1 + \frac{m^2}{2} \right) P_c$$

Where  $m$  is the modulation depth and  $P_c$  is the transmitter's output carrier power.

Table 4.1 and Table 4.2 show the cooling requirements for the transmitter and power transformer, respectively, when operating with various continuous tone modulation levels. To determine the number of British thermal units (Btu) being generated per hour as waste heat, multiply the waste heat (in watts) by 3.413. To determine the air conditioning (in tonnes), multiply the waste heat (in watts) by 0.000285.

Table 4.1: Cooling Requirements for the NX200

CARRIER POWER OUT (W)	MODULATION DEPTH (M x100)	AVERAGE POWER OUT (W)	WASTE HEAT (W)	WASTE HEAT (BTU/HOUR)	AIR CONDITIONING REQUIRED IN A CLOSED SYSTEM (TONNES)
200,00	100%	300,000	26,100	89,100	7.5
200,00	75%	256,250	22,300	76,150	6.4
200,00	50%	225,000	20,000	68,300	5.7

Table 4.2: Cooling Requirements for the Power Transformer

CARRIER POWER OUT (W)	MODULATION DEPTH (M x100)	AVERAGE POWER OUT (W)	WASTE HEAT (W)	WASTE HEAT (BTU/HOUR)	AIR CONDITIONING REQUIRED IN A CLOSED SYSTEM (TONNES)
200,00	100%	300,000	6700	22,900	1.9
200,00	75%	256,250	5700	19,500	1.7
200,00	50%	225,000	5000	17,100	1.4

**Note:** Although normal program audio is generally equivalent to 50-75% continuous tone modulation, Nautel recommends you design the cooling system for 100% continuous tone modulation, to allow sufficient overhead and for testing purposes.

## CLOSED LOOP OR FORCED AIR COOLING SYSTEMS

**INTAKE REQUIREMENTS.** Closed loop or forced air cooling systems can be used, so long as the air is well filtered to prevent dust and insects from entering the transmitter, and so long as a minimum of 3,000 cubic feet per minute (CFM) (1,500 per cabinet) at 0.5 pounds per square inch (PSI) is supplied to the intake duct.

**EXHAUST REQUIREMENTS.** 3,000 cubic feet per minute (CFM) (1,500 per cabinet).

**Note:** To ensure specified operation, the transmitter's fans cannot drive any extra back-pressure. Therefore, Nautel recommends that the exhaust duct system include exhaust fans.



**CAUTION:** The cooling system's evaporator may have a maximum air temperature capability [typically 35°C (95°F)]. If so, note that the maximum temperature rise from the transmitter's intake to exhaust is 20°C.

Nautel recommends you leave a gap between the top of the transmitter and the bottom of the exhaust hood, as shown in [Figure 4.3](#).

*Figure 4.3: Gap for Exhaust Air*



This gap will serve two purposes:

1. For air conditioned closed loop systems, the maximum air temperature into the evaporator may be limited to 35°C (95°F). By ensuring an adequate gap (as shown), the fan for the evaporator can be selected to draw more air than the rack will exhaust, allowing room air to mix with the warmer exhaust air from the transmitter, thus reducing the evaporator's intake temperature.
2. If the cooling system's exhaust fan fails or the exhaust duct is blocked, the transmitter is still able to exhaust into the room.

**COOLING SYSTEM CONFIGURATION**

Especially in warmer climates, Nautel recommends an air conditioned cooling system with ducted exhaust and free-air return. A split system air conditioner can be cost effective, provided the distance between the evaporator and condenser can be kept to a minimum. This configuration also minimizes dust and sand buildup within the equipment. An example of this type of system is shown in [Figure 4.4](#), which shows a combined NX400, 800 kW transmitter system with each transmitter having a dedicated split system air conditioner, with a third split system air conditioner used to cool the heat load in the room from various sources (e.g., power transformers, combiner losses, solar, other equipment, etc.).

[Figure 4.5 on page 4-7](#) shows a diagram of a split system air conditioner system, as well as examples of indoor an outdoor unit components.

*Figure 4.4: Air Conditioned Cooling System (combined 800 kW system shown)*

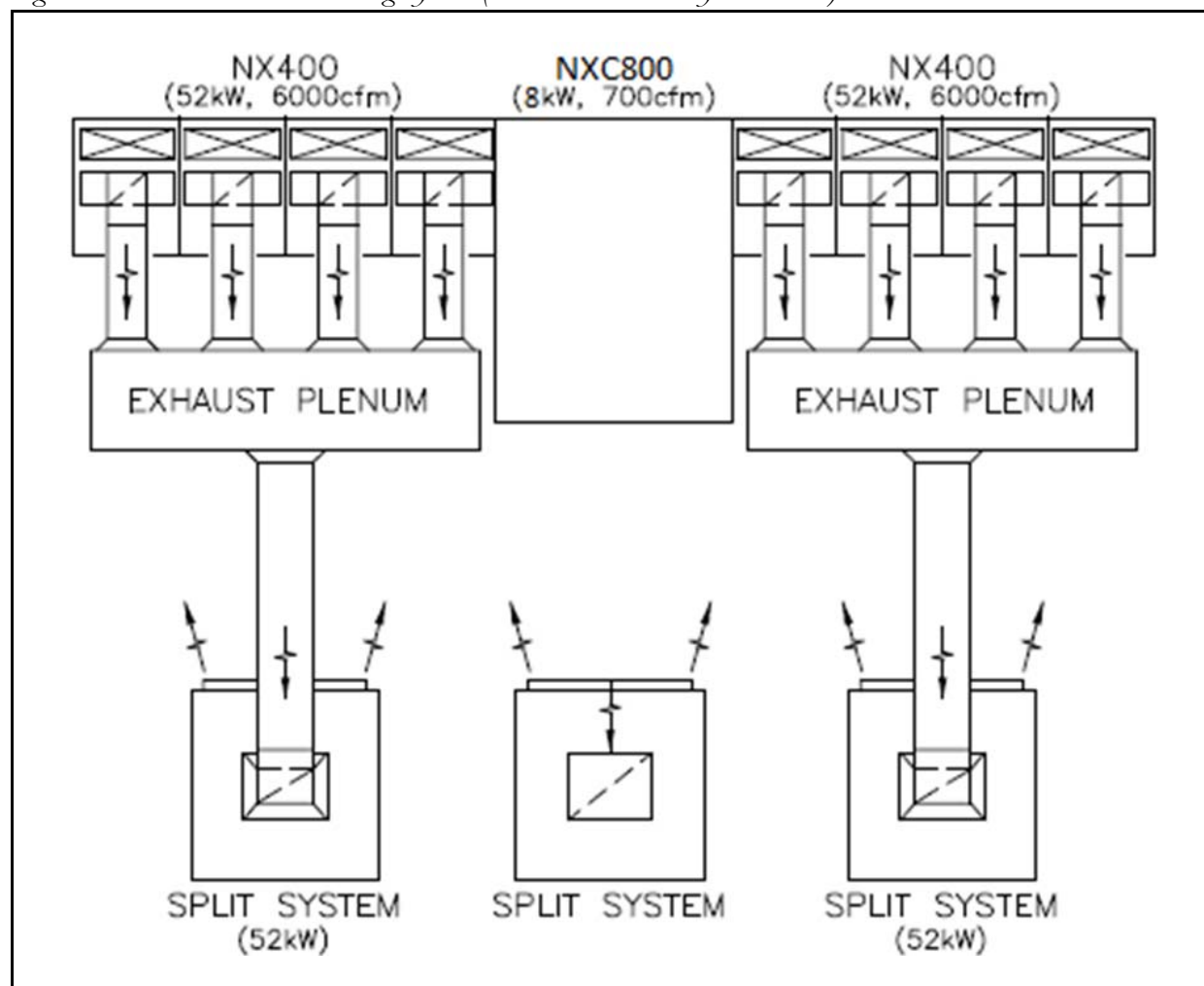
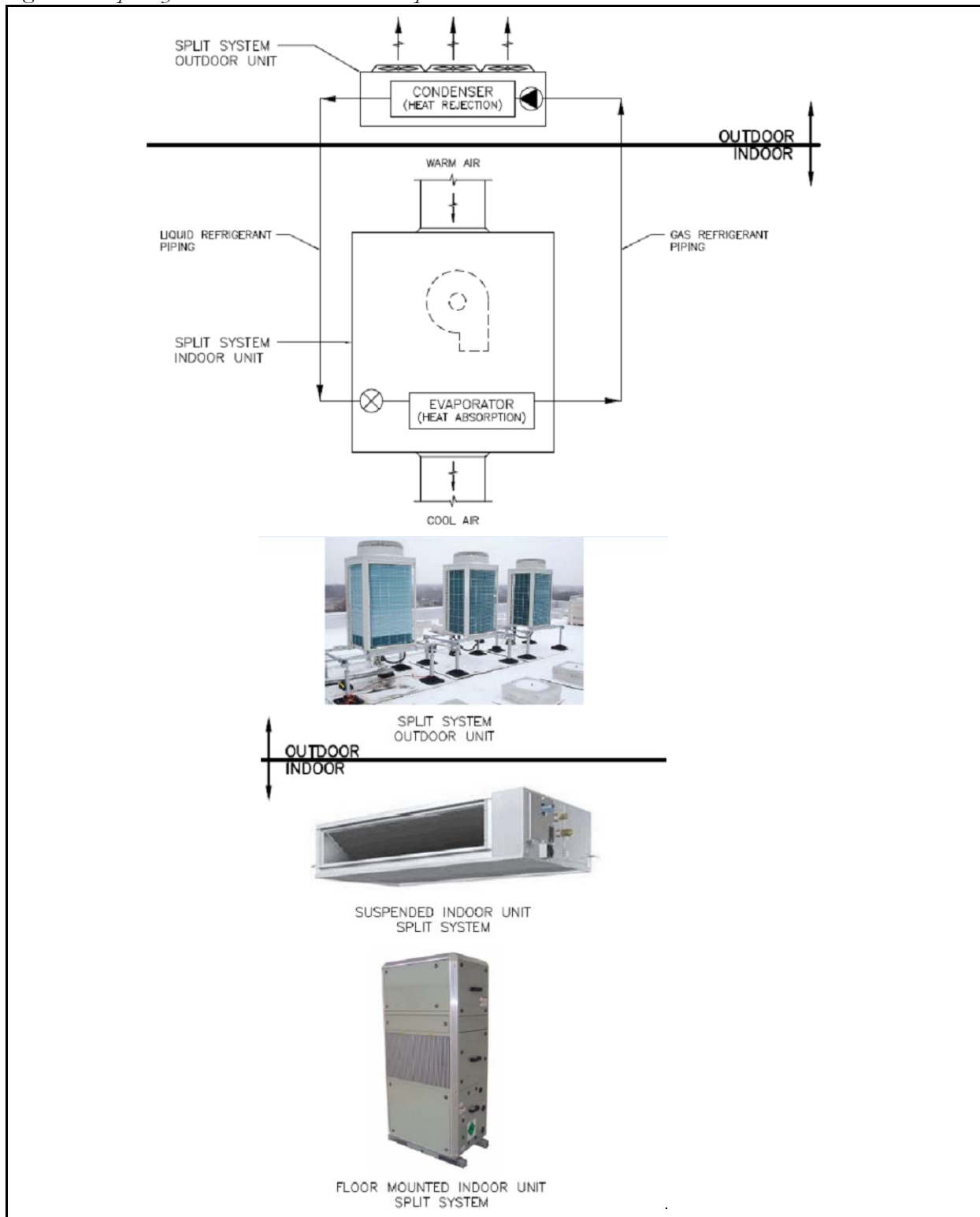

Figure 4.5: Split System Air Conditioner Examples



## TRANSFORMER COOLING CONFIGURATION

The transmitter's mains transformer is contained in an external cabinet and must also be cooled. If the transformer cabinet is located in the same room as the transmitter, you can include the transformer's heat losses with the room heat load. If the power transformer cabinet is located in a separate room, it is not necessary to use an air conditioner to cool it; it can be cooled by exchanging the air in the room, as shown in [Figure 4.6](#).

*Figure 4.6: Forced ventilation of the power transformer cabinet*

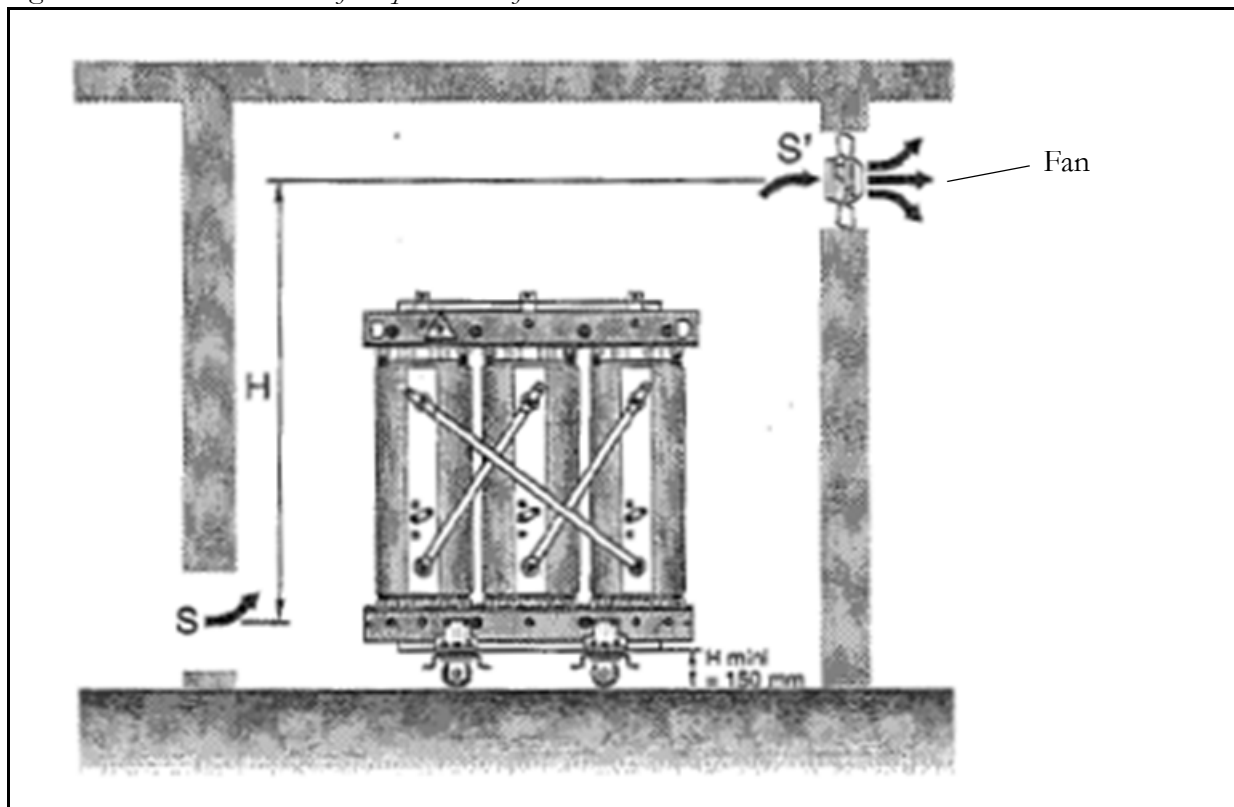

Forced ventilation of the power transformer is necessary for ambient temperatures greater than 20°C (68°F), or in small, poorly ventilated rooms. The fan can be thermostat-controlled and can operate as an extractor in the top part of the room. Calculate the recommended air flow ( $S'$ ) using:

$$S' \text{ [at } 20^{\circ}\text{C (68}^{\circ}\text{F)}] = 0.1 \times P \text{ m}^3/\text{s}$$

Where  $P$  is the transformer's waste heat (in kW, see [Table 4.2 on page 4-4](#)). Convert this to a CFM value by multiplying the result by 2119.



## HEATING

The transmitter room must contain a heating system that will ensure the ambient air temperature does not drop below 0°C (32°F).



---

## SECTION 5: ELECTRICAL REQUIREMENTS

This section describes electrical power and electrical protection requirements associated with the NX200 transmitter. This section includes the following topics:

- [Electrical power](#)
- [Station reference ground - see page 5-9](#)



**CAUTION: Technical pre-commissioning activities described in this section require technical decisions and the customization of electrical circuits. Do not attempt to perform these activities unless you are a certified electrician.**

Refer to *Nautel's Recommendations for Transmitter Site Preparation Manual* for information about requirements associated with lightning protection.

---

### ELECTRICAL POWER

The transmitter is preconfigured to operate from a 50/60 Hz 3-phase, 3-wire plus ground, Wye or closed delta ac power source. You select the specific voltage range when you order the transmitter.

#### VOLTAGE STABILITY

The ac power source nominal voltage must be stable to within  $\pm 15\%$  under all loading conditions. For optimal performance, Nautel recommends the voltage be stable within  $\pm 5\%$ . The transmitter contains circuitry that maintains the RF output at the preset carrier level for voltage variations within the specified range, provided the correct transformer tap is chosen.

#### POWER CONSUMPTION

When operating at 200 kW with 100% modulation by a continuous sine wave, power consumption is approximately 333 kW (350 kVA). When operating at 200 kW with no modulation, power consumption is 234 kW. Power consumption for a specific station will depend on the programming format and the level of audio processing. Nautel recommends the ac power source have a 25% over-capacity to ensure adequate regulation.

#### PRIMARY AC WIRING

When operating at 200 kW with 100% modulation by a continuous sine wave, line currents are as shown in [Table 5.1 on page 5-2](#). Use this information to determine appropriate wire and breaker sizes for the ac input. **NOTE:** Unless otherwise specified, Primary wiring is provided by the end user.

**Table 5.1: Approximate Line Currents for NX200**

AC INPUT VOLTAGE (V)	LINE CURRENT (A)
600	356
580	369
560	382
540	396
520	411
500	428
480	445
460	465
440	486
420	509
400	535
380	563
360	594
340	629

### AC POWER SWITCH

Install an external ac power disconnect between the ac power source and the transmitter's transformer. (Nautel can provide a suitable ac power disconnect, if required.) For safety, place the ac disconnect close to the transmitter and label it **TRANSMITTER EMERGENCY ON/OFF SWITCH**.

### AC TRANSIENT POWER PROTECTION

Protect all conductors from the ac power source by connecting bi-directional surge protection devices between each conductor and the station reference ground. In addition, pass all the conductors and ground, as a group, through a ferrite toroid. Install a ferrite toroid on the ac feed between the transmitter and the bi-directional surge protector.)

- To obtain the proper size ferrite toroid, contact Nautel support for recommendations (see [page 10-3](#)), or consult additional, outside suppliers.

---

A surge protector panel containing suitably rated varistors is available from Nautel. Install the surge protector panel close to the station reference ground, and as close as possible to the ac service entrance.

The ac power source usually has the lowest impedance path to ground during a lightning strike and normally carries most of the lightning-induced current away from the transmitter site. When lightning hits the power source (for example, striking a transmission line near the transmitter site), a significant induced current may flow towards the transmitter. The goal of lightning protection is to route the current around the transmitter to the best available ground.

For detailed information about surge protectors and lightning protection, refer to Nautel's *Recommendations for Transmitter Site Preparation Manual*.

**RECOMMENDED CONFIGURATION.** Use a 4-wire Wye (star) configuration, with the three phases balanced to ground.



**CAUTION:**

**Do NOT use open delta three-phase ac power sources that use two identical transformers. These systems are susceptible to third harmonic distortion and line transients, and may cause peak voltages to exceed the line voltage. This can cause increased power supply noise or even component failure (for example, rectifier failure).**

SECONDARY AC WIRING

The following information pertains to the wiring, cable connectors and cable tray support system, between the external power transformer cabinet and the main transmitter cabinets.

**Note:**  
*It is highly recommended that you purchase suitable wiring, hardware and cable trays from Nautel. If you decide to purchase these items from an alternate vendor, it is imperative that you read and understand the information presented in this section, as it provides specific part information as well as insight into some of Nautel's design philosophy behind the interconnect wiring requirements. **Do not** use the provided secondary wiring in place of primary wiring.*

**OVERVIEW.** See Figure 5.1. The NX200 transmitter requires a 3-phase, 400 V ac source, capable of supplying a 350 kVA power transformer. The transmitter consists of two cabinets (racks) and one external transformer. The transformer's secondary supplies three-phase ac power (4-wire: X1, X2, X3, X0) to each cabinet. A single-point ground connection is required between the transformer cabinet and the transmitter's station reference ground, located on top of rack 2. This ac power is applied to a 3-phase rectifier assembly in each cabinet. Each rectifier is fused at the source end in a fuse box attached to the side of the transformer cabinet.

**Figure 5.1: Transformer to Transmitter Interconnect Wiring**

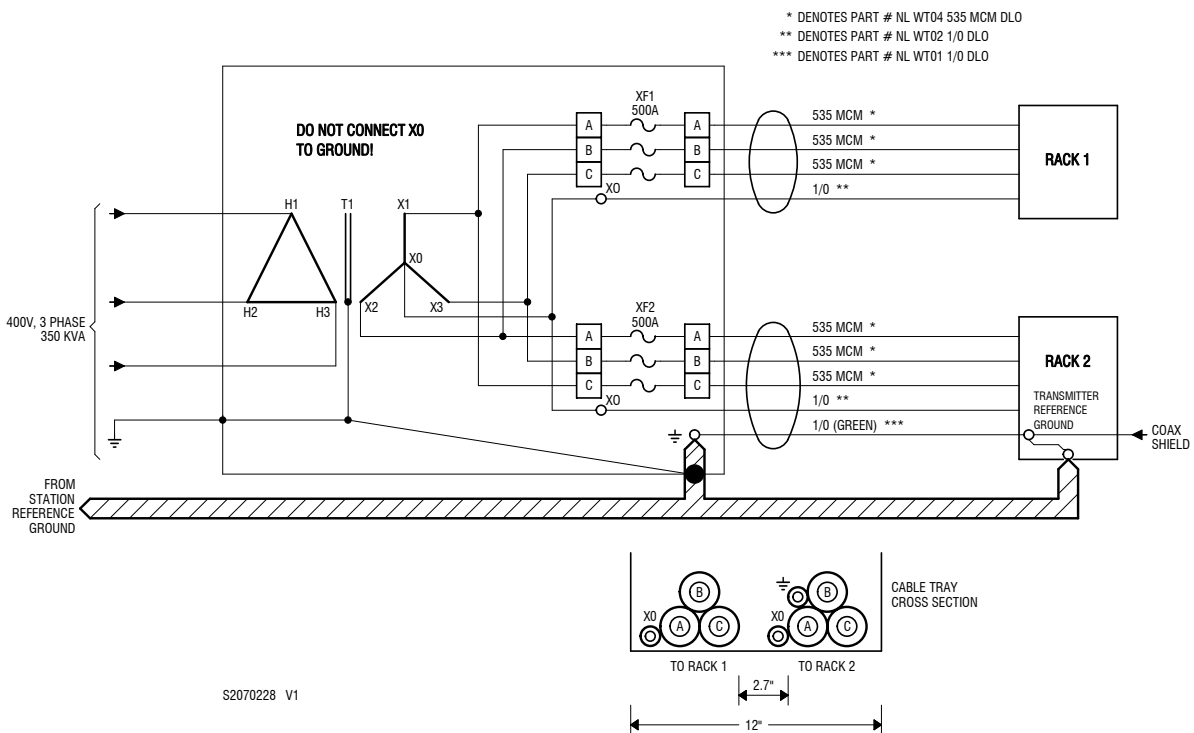

Additionally, each rack contains a single-phase 2 kW logic supply that receives its ac input from phase “A” and X0.



**WARNING: DO NOT CONNECT THE X0 TERMINAL OF THE POWER TRANSFORMER TO GROUND. BLOWN FUSES AND POSSIBLE DAMAGE TO THE 3-PHASE SCR MAY RESULT.**

500 A fuses have been selected to allow for thermal derating due to heat from the transformer cabinet enclosure.

**WIRE TYPE.** For the three-phase secondary connections, you requires a 535 MCM, tray rated diesel wire [available from Nautel, Part # WT04, Vendor (Anixter Inc.) # 5N-5351-FT4].

This wire has been selected for various reasons, including:

- 535 MCM correctly rated for the rectifier’s ac current requirements, considering bundling of three wires and temperature rating [50°C (122°F)]
- compatible with Cytolok cable connectors (see [“Cable connectors” on page 5-6](#))
- FT4 rated (for flame resistance) for use with cable trays (see [“Cable tray” on page 5-7](#))
- flexible, high-strand, allowing easy bend radius for drops from tray into transmitter racks

For the neutral and ground connections, you require a 1/0 AWG, tray rated wire [available from Nautel, Part # WT02 (black, X0) and Part # WT01 (green, ground)]. 1/0 AWG is the smallest allowable tray-rated wire diameter so the neutral wire size is determined by its FT4 rating rather than ampacity.

Wire lengths are dependent on the distance between the transformer cabinet and transmitter cabinets. All wiring can be purchased as part of Nautel’s Cable Tray Parts Kit (Nautel Part # 207-8385-07). In some cases, a custom cable tray is designed to meet a site’s specific requirements. If so, refer to the associated NX system documentation for details on the cable tray assembly.

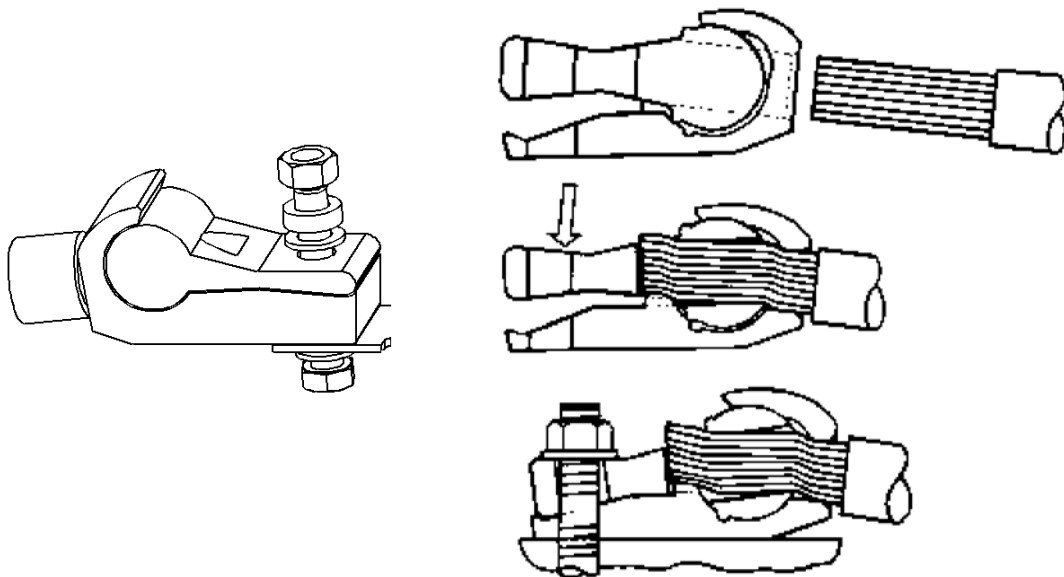
**Figure 5.2: Cytolok Cable Connectors**

**CABLE CONNECTORS.** See [Figure 5.2](#). For all interconnecting wiring between the transformer cabinet and transmitter cabinets, Nautel uses a spring compression cable connector called Cytolok [Nautel Part # JA93 (535 MCM wires) and Nautel Part # JA92 (1/0 AWG wires)].

These cable connectors offer various advantages over other connector types, including:

- no compression (crimp) tool required
- no Belleville washers required
- easy to install
- field proven reliability
- 500/600 MCM connector is compatible with 535 MCM multi-strand cable

Cytolok connectors are provided by Nautel in an ancillary kit. Refer to the *NX200 Installation Manual* for details on terminating wires in the Cytoloks.



**CABLE TRAY.** See Figure 5.3. For all interconnecting wiring between the transformer cabinet and transmitter cabinets, Nautel recommends (and can provide) a cable tray support system (Nautel Part # 207-8385-07, see [Table 5.2 on page 5-8](#)). Other options include armoured cable such as Teck90 or conduit.

If necessary, contact Nautel to discuss other available options to suit your cable tray requirements.

The advantages of using a cable tray system are:

- established, approved, reliable method to route high-current wiring
- easily accommodates top entry into transmitter cabinet (cable tray is suspended from ceiling) and supports wire weight
- fuse assembly on side of transformer cabinet pre-fitted to accept 4" x 18" cable tray; each transmitter cabinet pre-fitted to accept 4" x 6" cable tray

Cable tray lengths are dependent on the distance between the transformer cabinet and transmitter cabinets. All cable tray parts can be purchased as part of Nautel's Cable Tray Parts Kit (Nautel Part # 207-8385-07). Refer to Figure 5.3 of this manual and to the *NX200 Installation Manual* for details on installing the cable tray.

Plan your cable tray installation to ensure its position does not interfere with any exhaust ducting being used see [Section 3, "Physical requirements"](#).

**Table 5.2: Cable Tray Parts Kit (Nautel # 207-8385-07)**

DESCRIPTION	QTY	NAUTEL PART #	VENDOR #
Cable Tray Ladder, Alum, 12"W x 4"D x 120"L	1	HCT24	LCA43-12-12
Cable Tray, 12"-6" LH Reducer, 4" Deep	1	HCT32	LCA43-12/6 LHR
Cable Tray, 6x6x6 T, 4" Deep	1	HCT30	LCA43-06-12-T-R12
Cable Tray Ladder, Alum, 6"W x 4"D x 120"L	1	HCT23	LCA43-06-12
Cable Tray Elbow 90 Deg, 12" Vert Outside	1	HCT25	LCA43-12-12-V090-R12
Cable Tray Tee, Alum, 24" x 6" x 24", 4" Deep 12" R	4	HCT21	LCA43-12/6/12-12-RT-R12
Cable Tray elbow 90 Deg, 6" Vert Outside	2	HCT26	LCA43-6-12-V090-R12
Cable Tray 6" Endblank, 4" Deep	1	HCT33	LCA43-6-EB
Cable Tray Coupling, 4" Deep	5	HCT20	LCA43-C
Wire 1/0 Tray Rated, 90C, 600V, Green	30 ft.	WT01	3BALU-1011-04 AIW
Wire 1/0 Tray Rated, 90C, 600V, Black	60 ft.	WT02	3BALU-1011-02 AIW
Wire, Diesel, 535 mcm, FT4 Tray Rated	180 ft.	WT04	5N-5351
Cable Tray, Trapeze Hanger, 12"	4	HCT28	LCA43-12-TH
Cable Tray, Trapeze Hanger, 6"	4	HCT27	LCA43-6-TH
Threaded Rod, M12 x 1.75, 2m lg, Zn plated steel	16	HCT29	867-038ZP
Cable Cleat Kit	13	207-8373	-
Tyrap, .190W x 14.5Lg, WeatherResist., Black	40	HT59	PLT4S-MO
Bolt, Hex, M8 x 1.25 x 30 lg	16	HMBH03	-
Washer, Plain, M8	32	HMW06	-
Washer, Split, M8	16	HMW14	-
Nut, Hex, M12 x 1.75	70	HMN08	-
Washer, Plain, M12, SS	70	HMW08	-
Washer, Split, M12, SS	40	HMW16	-

**NOTES:**

- All parts prefixed by Nautel Part # HCT are from vendor Canadian Electrical Raceways.
- All parts prefixed by Nautel Part # WT are from vendor Anixter Inc.
- \*\* - denotes wire length is customer specific.

## STATION REFERENCE GROUND

See [Figure 5.1](#). Install a station reference ground that provides a continuous, low impedance path to the earth.

Connect the transmitter cabinet's designated safety ground point, the shield of the coaxial feedline, and the ground connection of the power source directly to the surge protector, using a 10 cm (4 in.) copper strap. Connect the surge protector to the station reference ground using a copper strap that is at least 10 cm (4 inches) wide.

Ac power enters the transmitter cabinet through the right side of the top panel (see [Figure 3.2 on page 3-4](#)).

Ensure that the transmitter site's grounding rods are adequate. For more information about electrical grounding protection, see Nautel's *Recommendations for Transmitter Site Preparation Manual*.



Power Transformer  
T1

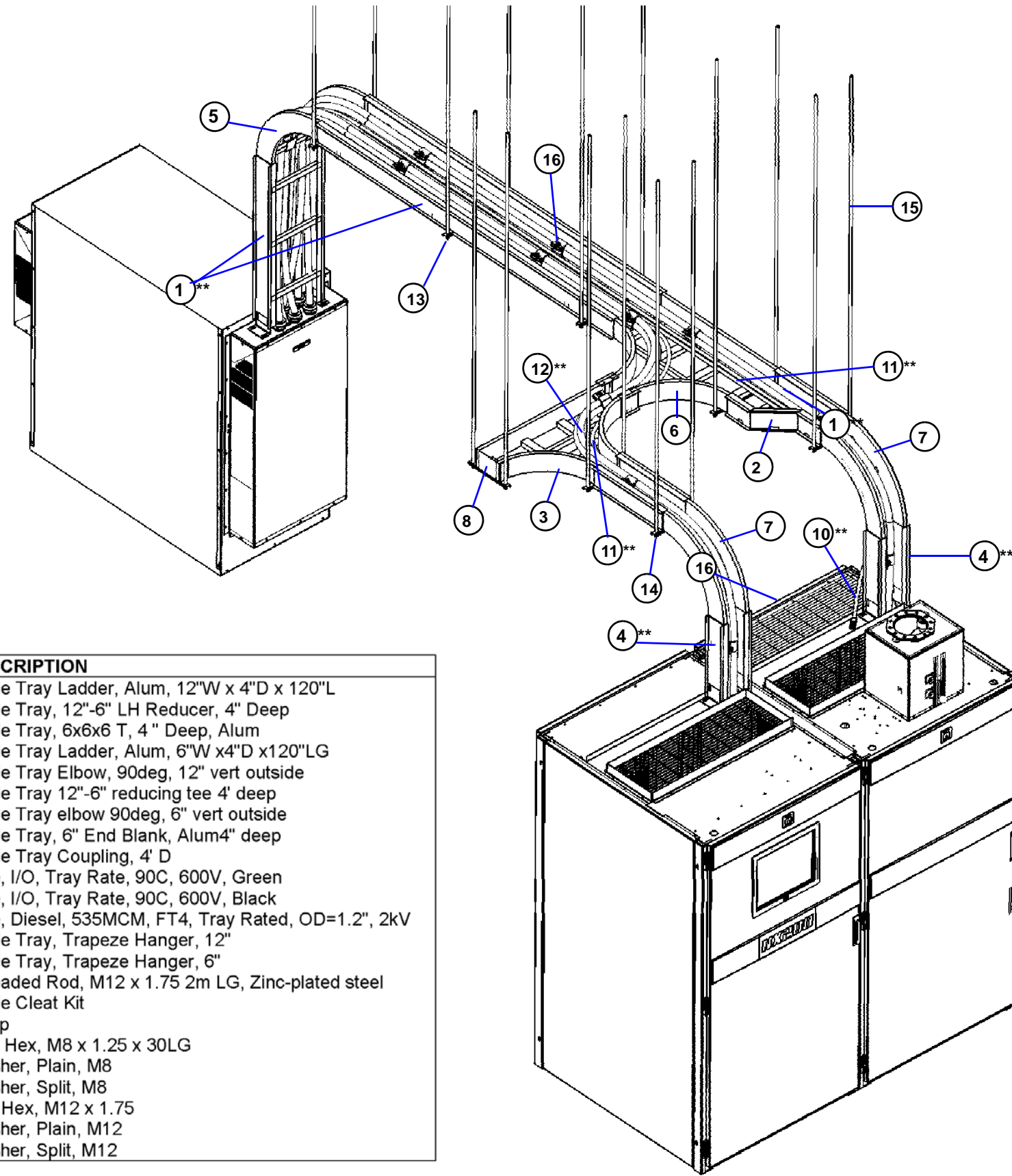

\* - Install Cable Cleat Kit every 1 m along horizontal rungs

\*\* - Denotes item is cut to length on site

ITEM #	QTY	NAUTEL #	VENDOR #	DESCRIPTION
1	1	HCT24	LCA43-12-12	Cable Tray Ladder, Alum, 12"W x 4"D x 120"L
2	1	HCT32	LCA43-12/6 LHR	Cable Tray, 12"-6" LH Reducer, 4" Deep
3	1	HCT30	LCA43-06-12-T-R12	Cable Tray, 6x6x6 T, 4" Deep, Alum
4	1	HCT23	LCA43-06-12	Cable Tray Ladder, Alum, 6"W x 4"D x 120"LG
5	1	HCT25	LCA43-12-12-V090-R12	Cable Tray Elbow, 90deg, 12" vert outside
6	1	HCT21	LCA43-(12-6-12)-12-RT-R12	Cable Tray 12"-6" reducing tee 4' deep
7	2	HCT26	LCA43-6-12-V090-R12	Cable Tray elbow 90deg, 6" vert outside
8	1	HCT33	LCA43-6-EB	Cable Tray, 6" End Blank, Alum 4" deep
9	5	HCT20	LCA43-C	Cable Tray Coupling, 4' D
10	30 ft	WT01	3BALU-1011004	Wire, I/O, Tray Rate, 90C, 600V, Green
11	60 ft	WT02	3BALU-1011-02	Wire, I/O, Tray Rate, 90C, 600V, Black
12	180 ft	WT04	5N-5351	Wire, Diesel, 535MCM, FT4, Tray Rated, OD=1.2", 2kV
13	4	HCT28	LCA43-12-TH	Cable Tray, Trapeze Hanger, 12"
14	4	HCT27	LCA43-6-TH	Cable Tray, Trapeze Hanger, 6"
15	16	HCT29	867-038ZP	Threaded Rod, M12 x 1.75 2m LG, Zinc-plated steel
16	13	207-8373	207-8373	Cable Cleat Kit
17	40	HT59	PLT4S-MO	Tyrap
01	16	HMBH03	-	Bolt, Hex, M8 x 1.25 x 30LG
02	32	HMW06	-	Washer, Plain, M8
03	16	HMW14	-	Washer, Split, M8
04	70	HMN08	-	Nut, Hex, M12 x 1.75
05	70	HMW08	-	Washer, Plain, M12
06	40	HMW16	-	Washer, Split, M12

Transmitter

Figure 5-3: NX200 Standard Cable Tray System

---

## SECTION 6: RF OUTPUT REQUIREMENTS

This section describes requirements associated with the antenna and RF cabling to be used with the NX200 transmitter.

Antenna considerations include the following:

- [Antenna feed cable](#)
- [Antenna system - see page 6-3](#)

For detailed information about protecting the antenna system from lightning strikes, see the *Nautel Site Protection Manual*.

---

### ANTENNA FEED CABLE

#### MAXIMUM VOLTAGE

The maximum voltage at the transmitter's connection to a 50  $\Omega$  load is 12,250 V peak, when operating at 200 kW, with 100% modulation, at a VSWR of 1.5:1.

#### HIGH VOLTAGE FEED THROUGH

Be very careful whenever a high voltage RF conductor passes through a wall or bulkhead. Gas insulation flashovers can occur in poor installations. Ensure that this part of your installation is installed by professionals experienced with high-power radio frequency circuits.

**INSULATOR FLASHOVER.** Surface flashovers along an insulator occur when there is an electrical breakdown in the gas (normally air) at its surface. The mechanism that triggers a flashover depends on the insulation surface conditions. Gas breakdown flashover occurs when one or more of the following conditions are met:

- The voltage field at the insulator surface or at an adjacent electrode reaches the critical breakdown level for the gas.
- The electrode or insulator interface is poor or dirty, resulting in a three material junction. This creates excessive high voltage stress on the air insulator, causing a gas breakdown flashover.
- Moisture damage on the insulator surface creates regions of high voltage that can cause a gas breakdown flashover.

**THREE-MATERIAL JUNCTIONS:** A frequent cause of breakdowns at an insulator surface is the junction of three materials: a metal conductor, a solid insulator, and a gas insulator. The insulators form a capacitive RF divider between the metal conductor and the grounded periphery. Since the dielectric constant of the solid is higher than the gas (air), the high voltage stress is concentrated on the air.

It is very important to minimize the junction's stress gradient and to avoid triple junctions wherever possible.



**WARNING: FAILURE TO PROVIDE CORRECT STRESS CONTROL AT HIGH RF VOLTAGE CONDUCTOR/INSULATOR JUNCTIONS CAN CAUSE INSULATOR BREAKDOWNS OR EVEN FIRES.**

**BOWL TYPE BUSHINGS.** Use bowl type bushing insulators to increase the surface tracking distance from the central conductor to the grounded periphery or wall.

**INSULATOR BREAKDOWN/DAMAGE.** An insulator can be damaged during gas breakdown flashovers. When current flows across the surface of an insulator, especially when it is coated with a conductive contaminant that is slightly damp, carbon tracks can form. Once this occurs, the track provides a conductive path and reduces the effectiveness of the insulator.

Pitting and erosion of the insulator may also occur. To reduce the possibility of tracking damage, clean all insulator surfaces periodically, and use stress control techniques at the conductor/insulator junction.

**OTHER CAUSES.** Other causes of breakdowns may include improperly adjusted spark balls or the disruption of air gaps by rain, snow, insects, birds, grass, or an accumulation of pollution (soot) on insulator surfaces.

### SMALL RADIUS CONDUCTORS

Be careful when using small radius conductors to carry high RF voltages and currents. If the radius is too small it may cause a local corona, which can lead to a breakdown.

### FEEDLINE TESTING

Test the RF transmission system from the transmitter flange to the antenna before putting the transmitter into service. This is very important, especially if you are re-using an existing site with a previously installed feedline. Ensure that the entire system can tolerate the expected peak voltages of normal operation, especially those occurring during modulation peaks, without breaking down.

---

## ANTENNA SYSTEM

Ensure that the antenna system meets or exceeds the standards specified in EIA Standard TR-101-A, paragraph 8(b), with a normal impedance of 50 ohms at the carrier frequency. The transmitter will operate with a maximum VSWR of 1.5:1, or with sideband VSWRs of up to 2:1 when the carrier frequency impedance is 50 ohms. However, overall system performance degrades as the VSWR increases.

Advances in digital modulation schemes like IBOC and DRM systems require better performance from antenna systems. To ensure the proper operation during digital broadcasting, ensure that the VSWR does not exceed the values recommended by each standard.

In order to achieve the proper sideband symmetry (Hermitian symmetry) needed for IBOC or DRM operation, you may need to adjust the tuning of the antenna system to balance the impedances at the sidebands. You must perform a full impedance sweep of the antenna system before broadcasting IBOC or DRM. This requires information about phase versus frequency for Hermitian symmetry at the power amplifier. The information will be provided with the transmitter at time of shipment. For information about your transmitter's RF phase, contact Nautel Customer Support.



*Note:*

*Hermitian symmetry may not be required for DRM if the VSWR across the bandwidth of the transmitted signal is very low. Contact Nautel for recommendations.*





---

## SECTION 7: PLANNING AUDIO INPUTS

The NX200 supports all current forms of AM broadcasting. This section describes the requirements associated with the audio feeds to the transmitter.

- [Analog inputs](#)
  - [Balanced \(mono\)](#)
  - [AES/EBU](#)
- [Digital inputs - see page 7-2](#)
  - [IBOC - see page 7-2](#)
  - [DRM - see page 7-2](#)
- [Other features - see page 7-3](#)
  - [Frequency synchronization signals - see page 7-3](#)

---

### ANALOG INPUTS

The transmitter does not have extensive audio processing capabilities. Use an external audio processor to ensure that the audio source material is processed properly. An audio processor will adjust the dynamic range, loudness, frequency response and symmetry parameters to suit the transmission system. Carefully control the peak levels.

For monaural applications, the audio may be processed to provide up to 135% positive peak program modulation, with a 200400 kW RF carrier at the nominal ac voltage.

Refer to the Operating section of the *NX200 Operations and Maintenance Manual* for an example of setting an analog preset.

The NX200 accepts the following analog inputs:

#### BALANCED (MONO)

Modulating audio must be applied from an external source to **BALANCED ANALOG AUDIO XLR** connector J12 on the control/interface PWB (A11A1). The audio source must be balanced, able to drive a 600  $\Omega$  load, and produce a level between -10 and +12 dBm for 100% modulation.

Only one analog input is provided. Program content from the input is applied to both exciters.

## AES/EBU

AES/EBU must be applied from an external source to **ANALOG AES/EBU** XLR connector J10 or J11 on the control/interface PWB (A11A1). The external source must produce a level between -30 and 0 dBFS for 100% modulation.

---

## DIGITAL INPUTS

The NX200 accepts the following digital inputs:

### IBOC

To use an IBOC (In Band On Channel) input, the NX200 requires the optional engine PWB (A11A7). The engine PWB accepts the digital audio data from an Importer/Exporter arrangement via a LAN (local area network) connection and, in conjunction with the control/interface PWB (A11A1), provides the LVDS signals (I and Q) to the exciter in CMOS format.

The digital audio data from the LAN/Exporter must be connected via an Ethernet cable to **ETHERNET** connector J1 on the engine PWB. The transmitter's GUI allows configuration of the IBOC input.

Refer to the Importer and Exporter documentation for more information.

Refer to the Operating section of the *NX200 Operations and Maintenance Manual* for an example of setting an IBOC preset.

### DRM

To use a DRM (Digital Radio Mondiale) input, the NX200 requires an external DRM modulator module. The DRM exciter module accepts the digital audio data via a LAN connection and provides the baseband I and Q signals to **AES/EBU** connector J10 on the control/interface PWB (A11A1), in AES/EBU format.

Refer to the DRM exciter module's documentation for more information.

Refer to the Operating section of the *NX200 Operations and Maintenance Manual* for an example of setting a DRM preset.

## OTHER FEATURES

The NX200 accepts the following other inputs:

### FREQUENCY SYNCHRONIZATION SIGNALS

You can apply a 10 MHz synchronization signal from an external source or using the optional GPS sync PWB, which can be installed in the transmitter.

#### OPTIONAL GPS SYNC PWB

A GPS sync PWB can be purchased that is capable of driving a 3.3 V or 5 V GPS antenna. If the optional GPS sync PWB is installed, it provides the necessary 10 MHz, 1 PPS and 1 kHz sync signals used by the exciter(s). The exciter uses these signals to synchronize the transmitter to this GPS reference. The GPS sync PWB connects to dual D-sub connector J5 of the control/interface PWB.

#### EXTERNALLY SOURCED

If you are using an externally generated 10 MHz signal (such as a GPS clock signal) for use as the reference frequency for the RF drive (carrier frequency), connect it to the **10 MHz SYNC** BNC connector J8 on the control/interface PWB. The external 10 MHz frequency reference must:

- remain stable at 10 MHz within  $\pm 20$  Hz
- have a peak-to-peak amplitude of between 2.2 V and 8.0 V (sine wave or square wave)
- be spectrally pure, since spurs may pass through to the transmitter output.

Figure 7.1: Audio Connections

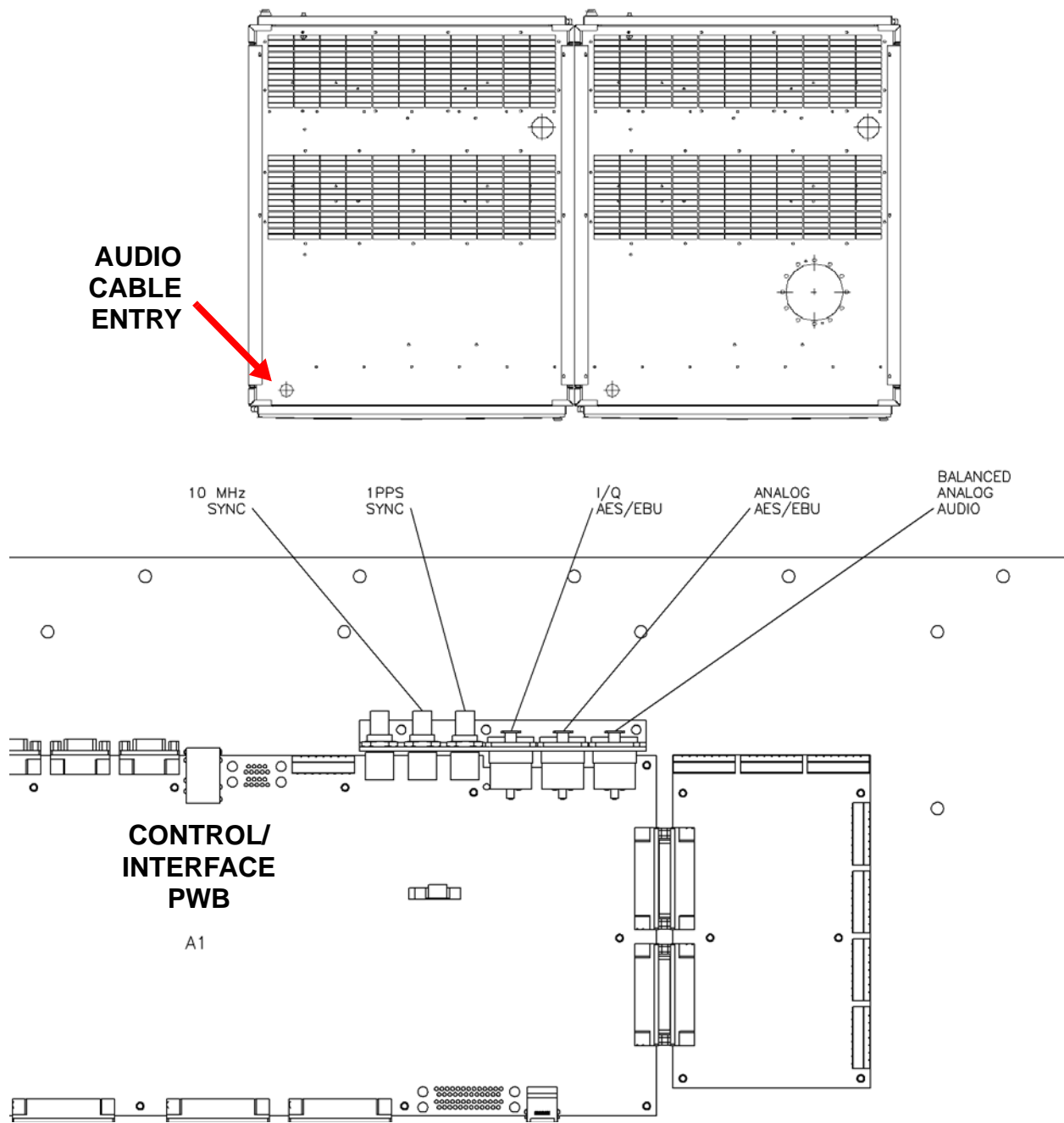

---

## SECTION 8: PLANNING CONTROL/MONITOR CONNECTIONS

This section describes the types of control and monitoring for the NX200 transmitter. Consider the following information and plan for the necessary requirements (wiring, remote switches/indicators, LAN, etc.):

- [AUI control](#)
- [Digital inputs](#)
- [Digital outputs - see page 8-7](#)
- [Analog outputs - see page 8-10](#)
- [Web based control - see page 8-11](#)
- [External interlock - see page 8-11](#)
- [PDM inhibit - see page 8-11](#)

---

### AUI CONTROL

The NX200's advanced user interface (AUI) lets you locally control all transmitter functions and set parameters and schedules. For detailed information about the AUI, refer to the *NX200 Operating and Maintenance Manual*. In addition, the AUI allows you to define the remote control of the on/off status, the active (A/B) exciter, the preset RF power level, the power level adjustment, and system alarm reset by means of a conventional remote control interface (see [“Digital inputs”](#) and [“Digital outputs” on page 8-7](#)). Most AUI functionality is also available via a LAN connection (see [“Web based control” on page 8-11](#)).

---

### DIGITAL INPUTS

You can connect to up to 16 digital inputs, which allow you to remotely control various operational characteristics of the transmitter. Each input is mapped to a control that is user defined. See [Table 8.1 on page 8-3](#) for a list of input options and their functional descriptions. See [Table 8.2 on page 8-4](#) for the associated input terminals and control switches (see [“Backup control switches” on page 8-6](#)) on the remote interface PWB (A11A4). Refer to the *NX200 Operations and Maintenance Manual* for instructions on changing the digital input settings, including which setting is assigned to the input pin and which logic is required to change (activate, enable, etc.) the setting.

Unless otherwise noted these inputs are only accepted by the transmitter if the remote/local status is set to remote. That setting can only be made by a local user using the front panel AUI.

The external digital input circuits interface with the transmitter via the remote interface PWB and then with opto couplers on the control/interface PWB. The opto couplers buffer and isolate the external circuits and prevent any unwanted transients from affecting transmitter operation while remote control is selected on the transmitter.

**Table 8.1: Digital Inputs - Selection Options**

Digital Input	Function
RF On	Same as pressing the AUI RF On button. Tells the transmitter to provide RF power if possible. Provide an active pulse to select.
RF Off	Same as pressing the AUI RF Off button. Tells the transmitter to disable RF power. Provide an active pulse to select.
Reset	Causes a system reset. Provide an active pulse to select.
Increase RF Power	Increases the power level of the current mode. Send an active pulse to increase the power slightly, or send a signal of greater duration to continue increasing power.
Decrease RF Power	Decreases the power level of the current mode. Send an active pulse to decrease the power slightly, or send a signal of greater duration to continue decreasing power.
Exciter A Select	Causes a changeover to select exciter A as the active exciter. Provide an active pulse to select.
Exciter B Select	Causes a changeover to select exciter B as the active exciter. Provide an active pulse to select.
Auto Exciter Changeover	Enables or disables automatic exciter changeover. Provide an active pulse to toggle between selecting automatic or manual.
Scheduler On/Off	Enables or disables the automatic mode scheduler. Provide an active pulse to toggle between selecting automatic or manual.
Max Power Lockout Select	Selects the associated power lockout limit (1 to 8) as active. Provide an active pulse to select.
Preset Select	Selects the associated user-named mode as the active preset. Provide an active pulse to select.



**Table 8.2: Digital Inputs - Remote Interface PWB Circuits**

Digital Input	Input Terminal	Switch
1	J7-8	01
2	J7-7	02
3	J7-6	03
4	J7-4	04
5	J7-3	05
6	J7-2	06
7	J8-8	07
8	J8-7	08
9	J8-6	09
10	J8-4	10
11	J8-3	11
12	J9-8	12
13	J9-7	13
14	J9-6	14
15	J9-4	15
16	J9-3	16

## EXTERNAL SWITCHING CIRCUIT REQUIREMENTS

The switching circuits for the remotely controlled functions must be the equivalent of a normally open (momentary) switch. The switches must be configured to operate as a single-ended input using the transmitter's 15 V dc as the source, or as a differential input using an external dc power supply (12 - 18 V) applied to J6-7 or J6-8. The control/interface PWB contains a selection circuit that allows you to select internal (single-ended, see Option 1) or external (differential, see Option 2) dc power supply for all digital inputs.

Inputs are toggled between states by an active pulse unless otherwise noted. To ensure proper operation, the duration of the active pulse should be a minimum of 250 ms. Refer to the *NX200 Operations and Maintenance Manual* to see the various logic control options for digital inputs.

**OPTION 1 - SINGLE ENDED INPUT (INTERNAL DC SUPPLY).** When you use the transmitter's 15 V as the current source for a control function's opto coupler, configure the circuits on the control/interface PWB for single ended inputs (see [Figure 8.1](#)). The INT/EXT 3-pin header (E3) must have its 2-socket shunt post connected between pins 2 and 3 to configure the circuit.

**Figure 8.1: Single-Ended Input Selected**

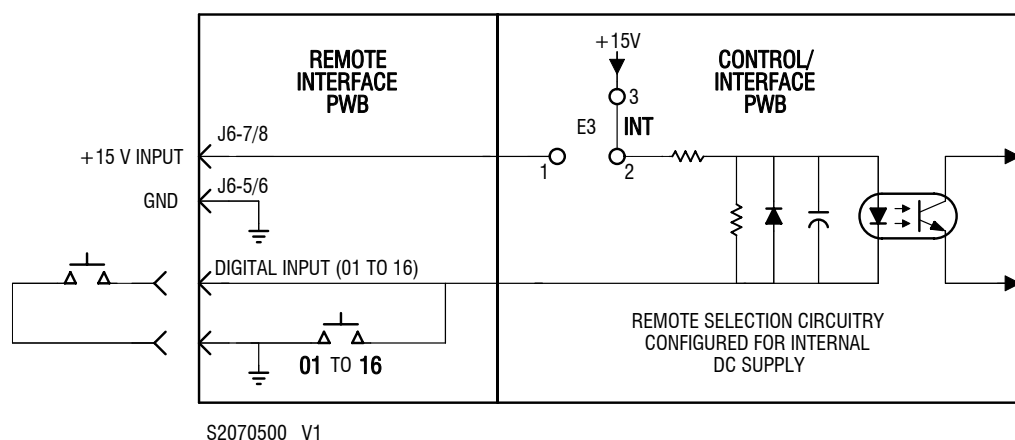

When the digital input is configured for logic '0', a negative logic (current-sink-to-ground) command must be applied to the appropriate digital input (1 through 16). To avoid a ground loop, obtain the ground from the remote interface PWB (J7-1 or 5, J8-1 or 5, or J9-1 or 5).

**OPTION 2 - DIFFERENTIAL INPUT (EXTERNAL DC SUPPLY).** When you use an external dc voltage (12 V to 18 V) as the current source for a control function's opto coupler, configure the control function's external switching circuit and the control/interface PWB's selection circuit for a differential input (see [Figure 8.2 on page 8-6](#)). The INT/EXT 3-pin header (E3) must have its 2-socket shunt post connected between pins 1 and 2 to configure the circuit.

**Figure 8.2: Differential Input Selected**

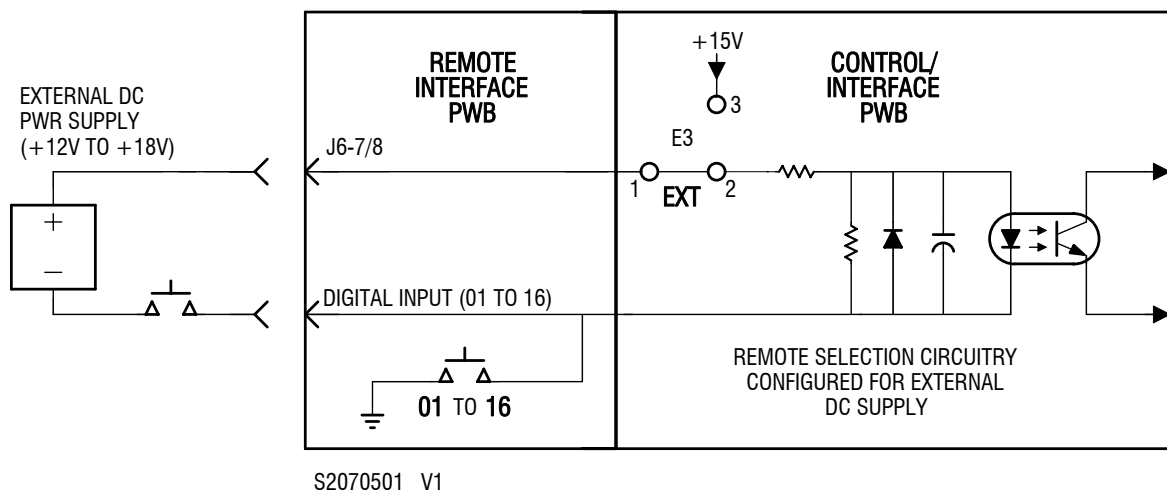

The normally open/momentarily closed switch should be located between the dc supply's negative output and the digital input.

### BACKUP CONTROL SWITCHES

The remote interface PWB contains a push-button switch [01 (S1) through 16 (S16)] for each of the 16 digital inputs. Each switch provides a means to locally activate its associated digital input in the event that the associated AUI control is not available. See [Table 8.2 on page 8-4](#) to determine the switch associated with each of the digital inputs.

Below each switch is a blank, white label to allow for labelling of the control.

### DIGITAL INPUT CONNECTIONS

Digital inputs 1 through 16, as required, connect to the terminals of connectors J7, J8 and J9 on the remote interface PWB (A11A4). See [Table 8.2 on page 8-4](#) to determine the input terminal associated with each digital input.

## DIGITAL OUTPUTS

Up to 16 digital outputs, that indicate either the presence of various alarms or the status of operator controlled circuits, are available for remote monitoring on connectors J3, J4 and J5 on the remote interface PWB (A11A4). The sources and active logic levels of these digital outputs are user-defined. See [Table 8.3 on page 8-8](#) for a list of output options and their descriptions. See [Table 8.4 on page 8-9](#) for the associated output terminals and status LEDs (see “[LED configuration](#)”) on the remote interface PWB.

A switching device for each digital output provides the desired active logic when a true condition exists. Nautel presets all digital outputs for Logic ‘0’ Active.

If the digital output is configured as Logic ‘0’ Active (see the *NX200 Operations and Maintenance Manual*), then the digital output’s switching circuit will provide a current-sink-to-ground when a logic true condition exists and an open collector for a logic false condition.

If the digital output is configured as Logic ‘1’ Active (see the *NX200 Operations and Maintenance Manual*), then the digital output’s switching circuit will provide an open collector when a logic true condition exists and a current-sink-to-ground for a logic false condition.

## LED CONFIGURATION

The remote interface PWB contains a bi-colour LED (DS1 through DS16) and a shorting jumper (E1 through E16) for each of the 16 digital outputs. Each LED can be configured to glow green for a status output or red for an alarm output, by setting the position of the associated shorting jumper. For a status output, install the shorting jumper to short positions 1 and 2 of its post. For an alarm output, install the shorting jumper to short positions 2 and 3 of its post. See [Table 8.4 on page 8-9](#) to determine the LED and shorting jumper associated with each digital output.

Below each LED is a blank, white label to allow for labelling of the status/alarm output.

## DIGITAL OUTPUT CONNECTIONS

Digital outputs 1 through 16, as required, connect to terminals of connectors J3, J4 and J5 on the remote interface PWB (A11A4). See [Table 8.4 on page 8-9](#) to determine the output terminal associated with each digital output.

**Table 8.3: Digital Outputs - Selection Options**

Digital Output	Description
Remote Status	Indicates the local/remote control status of the transmitter. Logic true if transmitter is in remote mode. Logic false if transmitter is in local mode. Changes can only be made remotely if the transmitter is set to remote mode. The local user's control of transmitter operation is limited, unless the transmitter is set to local mode.
RF On Status	Indicates the on/off status of the transmitter's RF power stage. Logic true is RF is enabled.
Exciter A Status	Indicates which exciter is presently active. Logic true if exciter A is active. Logic false if exciter B is active.
Auto Exciter Changeover Status	Indicates the status of the auto exciter changeover function. Logic true if enabled (auto). Logic false if disabled (manual).
Main Exciter Status	Indicates which exciter is selected as main. Logic true if exciter A is main. Logic false if exciter B is main.
Mode Scheduler Status	Indicates the status of the mode scheduler function. Logic true if enabled (scheduler). Logic false if disabled (manual).
Various Alarms	Logic true condition indicates the associated alarm is occurring. Logic false if it is not occurring.
Watchdog Reset	<b>Must be configured as Digital Output 1.</b> Indicates that a watchdog reset is occurring, due to an error in communication between the Controller and the single-board computer.
Preset Status	Indicates that the associated user-named mode is currently active.
Max Power Lockout Status	Indicates that a maximum power lockout limit (1 to 8) has been selected..Logic true if the lockout has been selected. Logic false if the lockout has not been selected.
Remote Input	Mimics the logic of the associated remote input selection. Example: If Remote Output 5 is set to Remote Input, it will mimic the logic received on remote input pin 5. This is typically used for debugging remote inputs.

**Table 8.4: Digital Outputs - Remote Interface PWB Circuits**

<b>Digital Output</b>	<b>Output Terminal</b>	<b>Status LED</b>	<b>Shorting Jumper</b>
1	J3-8	DS1	E1
2	J3-7	DS2	E2
3	J3-6	DS3	E3
4	J3-4	DS4	E4
5	J3-3	DS5	E5
6	J3-2	DS6	E6
7	J4-8	DS7	E7
8	J4-7	DS8	E8
9	J4-6	DS9	E9
10	J4-4	DS10	E10
11	J4-3	DS11	E11
12	J5-8	DS12	E12
13	J5-7	DS13	E13
14	J5-6	DS14	E14
15	J5-4	DS15	E15
16	J5-3	DS16	E16

## ANALOG OUTPUTS

The transmitter provides sample signals that let you monitor transmitter performance. The sources of these analog outputs are pre-defined and configured at Nautel. See [Table 8.5](#) for a list of these pre-defined outputs, their descriptions and their associated output terminals on the remote interface PWB. The outputs are op-amp buffered outputs from an analog-to-digital converter (ADC). The dc voltage of each output is between 0 to 6 V, and varies within the real limits of the parameter being monitored. The monitoring circuit's impedance for each analog output must be greater than 1,000 ohms.

In addition to the four pre-defined analog outputs, a true RF sample of the RF output voltage waveform is available for external monitoring.

## ANALOG OUTPUT CONNECTIONS

Analog outputs 1 through 4 connect to terminals of connector J6 on the remote interface PWB (A11A4). See [Table 8.5](#) to determine the output terminal associated with each analog output.

**Table 8.5: Factory Defined Analog Outputs**

Analog Output	Description	Output Terminal
1. Forward Power	Reports a sample of the transmitter's forward power level. This dc voltage is a pure square law function and will be full-scale (6 V) when the forward power is 200 kW.	J6-4
2. Reflected Power	Reports a sample of the transmitter's reflected power level. This dc voltage is a pure square law function and will be full-scale (6 V) at the user defined when the reflected power is 32 kW.	J6-3
3. B+ Voltage	Reports a sample of the control cabinet's B+ dc voltage level. This dc voltage is a linear function and will be full-scale (6 V) when the B+ voltage in the control cabinet is 400 V.	J6-2
4. Dc Current	Reports a sample of the dc current level. This dc voltage is a linear function and will be full-scale (6 V) when the dc current is 500 A.	J6-1

## WEB BASED CONTROL

An Ethernet port is available on J1 of the SBC's motherboard (A1U1) on the back of the control cabinet's front door. This port allows a user with proper authentication to remotely control and interrogate the NX200's operational status. Most functionality available on the front panel AUI is available remotely, provided the user has been granted proper authorization.

---

## EXTERNAL INTERLOCK

An external safety interlock is available between **EXT INTLK** terminals J6-1 and J6-2 of the control/interface PWB (A11A1) behind the front door. This connection allows you to connect an external safety interlock circuit that provides an emergency RF inhibit control for the NX200. It must present a short circuit (low impedance) between the terminals when the interlock circuit is intact and it is safe to enable the RF output. It must present an open circuit when any interlock switch is activated and the RF output requires inhibition. You can install any number of serial interlock switches provided the above conditions are met.

---

## PDM INHIBIT

An external PDM inhibit is available between **PDM INHIBIT** terminals J6-3 (+) and J6-4 (-) of the control/interface PWB (A11A1) behind the front door. This connection allows you to connect an external PDM inhibit circuit that provides an emergency RF inhibit control for the NX200. This circuit can be configured as single-ended or differential, using shorting jumper E2 on the control/interface PWB.

**SINGLE ENDED INPUT (INTERNAL DC SUPPLY).** If you use the transmitter's 15 V as the current source for the PDM inhibit circuit, install the **PDM INH** shorting jumper (E2) in the **INT** position (shorting pins 2 and 3).

**DIFFERENTIAL INPUT (EXTERNAL DC SUPPLY).** When you apply an external dc voltage (12 V to 18 V) to terminal J6-3 (+) as the current source for the PDM inhibit circuit, install the **PDM INH** shorting jumper (E2) in the **EXT** position (shorting pins 1 and 2).

In either case, the PDM inhibit circuit must present a high impedance (open circuit) to terminal J6-4 (-) when it is safe to enable the RF output. It must present a low impedance (near ground potential) when the RF output requires inhibition.





---

## SECTION 9: PARTS AND TOOLS

This section describes parts associated with the NX200 transmitter, and tools needed during installation and routine operation. Topics include:

- [Parts supplied by Nautel](#)
- [Parts not supplied by Nautel - see page 9-2](#)
- [Parts ordering - see page 9-2](#)
- [Module replacement program - see page 9-2](#)
- [Tools for installation - see page 9-3](#)

---

### CONTACTING NAUTEL

You can reach Nautel to order parts or for technical assistance at:

#### **Nautel Limited**

10089 Peggy's Cove Road  
Hackett's Cove, NS Canada B3Z 3J4  
Phone: +1.877.628.8353 (Canada/US)  
+1.902.823.5100 (International)

Fax: +1.902.823.3183

Email: [support@nautel.com](mailto:support@nautel.com)

Web: [www.nautel.com](http://www.nautel.com)

---

### PARTS SUPPLIED BY NAUTEL

#### ANCILLARY PARTS KIT

An ancillary parts kit is shipped with the NX200. This kit contains hardware needed during the installation process. The kit includes toroids, spare fuses, screws and other miscellaneous hardware.

## DOCUMENTATION

See “NX200 transmitter manuals” on page xii.

---

## PARTS NOT SUPPLIED BY NAUTEL

Some parts and materials required to complete installation are not supplied by Nautel. The parts you need vary with the installation requirements. The list of parts you normally provide yourself during installation include:

- A suitable 50  $\Omega$  RF output coaxial cable, terminated by the proper connector, complete with center male connector at the transmitter end.
  - All external control and monitor wiring, including the associated terminating devices, conduit and conduit clamps.
  - All electrical power cables, including conduit, terminating devices, and conduit clamps.
- 

## PARTS ORDERING

You can order replacement parts from your Nautel sales agent, or directly from Nautel through the Nautel website.

---

## MODULE REPLACEMENT PROGRAM

Nautel offers a module replacement program for customers who require expedited servicing and replacement of faulty modules. The module replacement program provides immediate replacement of failed modules with refurbished modules.

- The replacement module is shipped to the customer as soon as the customer reports the failure. The customer then returns the failed module to Nautel using the same shipping package.

## TOOLS FOR INSTALLATION

The tools you need during transmitter installation include the following:

- Digital voltmeter
- Philips screwdrivers, sizes #1 and #2
- Pliers
- Wire cutters
- Slot screwdriver, 5 mm (3/16 inch)
- Metric and Imperial socket set up to 24 mm (15/16 inch)
- Metric and Imperial wrench set up to 25 mm (1 inch)
- Feeler gauge (to measure spark gap)
- Torque wrench (capable of up to 275 in-lbs or 31 N-m)



---

## SECTION 10: PRE-INSTALLATION ASSISTANCE

Nautel provides a number of support options to help you during pre-installation planning and preparation:

- [Pre-installation consulting](#)
- [Installation and commissioning service](#)
- [Online documentation - see page 10-2](#)
- [On-site support - see page 10-3](#)
- [Training - see page 10-3](#)
- [Extended warranties - see page 10-4](#)

---

### PRE-INSTALLATION CONSULTING

Nautel field support specialists are available to answer questions and work with you to ensure that your site will be ready for the installation of your NX200 transmitter. For support, contact Nautel Customer Service and request assistance (see [“On-site support” on page 10-3](#)).

---

### INSTALLATION AND COMMISSIONING SERVICE

Nautel offers an installation and commissioning service to customers who want assistance with configuring and commissioning a new Nautel transmitter. After the customer completes the transmitter assembly and installation, Nautel technical personnel will spend up to three days on-site to help make the ac power, RF and remote connections, and to assist with the configuration and testing of Nautel equipment.

The customer is responsible for ensuring that the following stages of installation have been completed, prior to the arrival of Nautel personnel:

- Ac power wiring for the transmitter has been installed and connected at the breaker panel or the building's service entrance.  
If local electrical codes allow Nautel personnel to connect the transmitter to the ac supply, using the customer's cable, that task is included in this service. Otherwise, the customer must ensure that an approved electrician is present for this task.

- The customer has prepared the RF coaxial cable – used to connect the transmitter to the antenna – and installed the required connector. The customer has also installed the RF coaxial cable in place and connected it to the antenna, while leaving the transmitter end of the cable unconnected.
- Where required, all remote control and monitoring cables have been installed and connected to the station equipment (e.g., modulation monitor, frequency monitor, and power meter).
- The site has been made ready for the equipment, and adequate protection against lightning and lightning-induced transients has been provided.
- The transmitter has been unpacked, closely checked for any damage caused by shipping, and then assembled.
- The following test equipment has been made available at the site:
  - Two-channel oscilloscope (with probes)
  - Audio signal generator
  - Distortion analyzer
  - Modulation monitor
  - Frequency counter
  - 50  $\Omega$  test load (rated for 150% of carrier power, VSWR less than 1.1:1)

Nautel's service representative takes full responsibility for commissioning the transmitter, validating all external interfaces (i.e., the ac supply, RF output, remote control and monitoring equipment) and checking out the equipment prior to activation. The service representative turns on the transmitter, performs all adjustments and set-up procedures, and carries out *proof of performance* tests at the site. These tests ensure that the transmitter is operating normally in compliance with its specifications. The service representative also provides a demonstration and a short explanation of the operation of the transmitter. Finally, the customer signs an *Acceptance of Installation Certificate* that provides feedback to Nautel regarding the commissioning service.

---

## ONLINE DOCUMENTATION

Nautel provides documentation online to customers, letting you familiarize yourself with specifications, operation, maintenance and troubleshooting prior to the delivery of your equipment.

---

- Documentation is also provided on CDROM and in paper binders that are delivered with the transmitter.
- 

## ON-SITE SUPPORT

If you require on-site assistance, Nautel's field support specialists can help you prepare your site, and ensure that your NX200 transmitter installation can proceed as quickly as possible. For more information about onsite support, including scheduling and pricing, contact Nautel Customer Service:

- Telephone: +1.902.823.5100
- Fax: +1.902.823.3183
- Email: [support@nautel.com](mailto:support@nautel.com)

After business hours (Atlantic time or Eastern time in North America), requests sent by fax or email will be acknowledged within one working day.

---

## TRAINING

Nautel's SBE-certified broadcast training programs satisfy your day-to-day knowledge requirements. Students participating in Nautel's broadcast transmitter or RF basics training programs earn one SBE credit for each completed day of training. Nautel's comprehensive selection of training programs will help a customer's staff develop valuable skill sets, reduce downtime, and make the most of the customer's technology investment.

Nautel training programs are made up of individual modules that can be *mixed and matched* to meet the customer's specific training needs. All Nautel training courses are available at the Nautel Training Center. Training can also be provided at the customer's facility, for training the customer's technical staff on the customer's transmitter.

All Nautel training courses combine classroom and hands-on laboratory work to ensure a balanced learning experience. Many of our classes also include diagnostic lab exercises.

Nautel training courses feature:

- Limited class sizes to ensure maximum student participation and access to equipment
  - Emphasis on need-to-know, day-to-day knowledge
-



- Labs that focus on the tasks most often performed at the transmitter site.

## **NX SERIES ON-SITE OR FACTORY TRAINING**

This includes product overview, site and pre-installation, theory of operation, testing and adjustments, operating instructions, system-level troubleshooting, component-level troubleshooting, component parts lists, and wiring route sheets.

---

## **EXTENDED WARRANTIES**

Nautel's standard 13-month warranty provides excellent coverage and satisfies most customers' needs. However, if you want extended coverage, Nautel offers one- and two-year Extended Warranty Plans to cover electrical and mechanical repairs or replacements for all Nautel equipment.

### **COVERAGE**

The Extended Warranty Plan includes:

- A module exchange program for many common modules and circuit boards (North America only)
- Toll-free hotline (North America only)
- Necessary labor performed by Nautel authorized personnel to repair the product to meet factory specifications
- Necessary components
- Modifications to correct performance problems
- Return shipping.

## DETAILS

Extended Warranty Plans must be purchased prior to the expiration of original 13-month warranty.

One-year Extended Warranty Plans add an additional year (12 months) of coverage after the end of the customer's standard 13-month warranty. The two-year plan adds an additional two years (24 months).

Only repairs done at Nautel's facilities or by Nautel authorized personnel will be covered by the Extended Warranty Plans.

You must ship faulty products back to Nautel, prepaid, and in the original package or in a package that provides equivalent protection.

Nautel can choose to repair or replace equipment.

## PURCHASING A ONE- OR TWO-YEAR EXTENDED WARRANTY PLAN

If the transmitter is still covered by its original 13-month warranty period, you can contact Nautel by telephone, fax, mail, or email with the model number, serial number and date of purchase.

Once you purchase a Nautel Extended Warranty Plan, you receive an extended warranty plan certificate, plan number, and a toll-free number (North America only) to call for any service-related issues.

## USING THE EXTENDED WARRANTY PLAN

Contact Nautel's Canadian or U.S. service facility by phone, fax, or email as soon as a problem occurs. The following will be required when contacting Nautel:

- Extended warranty plan number
- Product model number
- Serial number
- Brief description of the problem

If Nautel's service technicians are unable to solve the problem over the telephone, Nautel will give you an RMA number. You then return the module or circuit board to a Nautel service facility, so that Nautel can provide a replacement. *Do not ship a component back to Nautel until you have an RMA number.*



---

## SECTION 11: LIST OF TERMS

This section defines some of the terms that are used in Nautel documentation.

**ADC.** Analog to Digital Converter.

**AES-EBU.** Audio Engineering Society/European Broadcasting Union (AES/EBU) is the name of a digital audio transfer standard. The AES/EBU digital interface is usually implemented using 3-pin XLR connectors (the same type connector used in professional microphones). One cable carries both left and right-channel audio data to the receiving device.

**B+.** The high voltage dc generated by the transmitter's ac power supply for use within the transmitter. The B+ voltage is used to supply the transmitter's modulators and other transmitter circuitry.

**CUTBACK.** A reduction in RF output power, caused by a total power limit fault or the occurrence of three shutbacks within a five second period.

**DAC.** Digital to Analog Converter.

**DAM.** Dynamic Amplitude Modulation.

**DCC.** Dynamic Carrier Control.

**DRM.** Digital Radio Mondiale. A set of digital audio broadcasting technologies designed to work existing AM radio channels.

**DSP.** Digital Signal Processing.

**FPGA.** Field Programmable Gate Array.

**HD RADIO.** HD Radio is another term for In Band On Channel (IBOC) technology. HD Radio is a trademark of iBiquity Digital Corporation.

**IBOC.** Nautel In-Band-On-Channel technology provides high quality digital audio over existing AM radio channels.

**IPM.** Incidental Phase Modulation

**LATCHING ALARM.** An alarm that, while active, keeps the transmitter in an 'RF inhibited' state. This type of alarm (e.g., High SWR Shutdown) require a reset - locally or remotely - to attempt to restore transmitter operation.

**NE IBOC.** Nautel's In-Band-On-Channel signal generator. See IBOC. Required for NX series IBOC installations.

**PDM.** Pulse Duration Modulation.

**PRESET.** A setting that controls power level, active exciter, and power scheduler status on a time-of-day and date basis. Exciters can be configured on a preset for a specific operating mode (for example, Exciter A - conventional AM, and Exciter B - IBOC). The NX200 allows you to pre-program multiple presets.

**SHUTBACK.** A complete loss of RF output power, caused by any one of a variety of faults, including high VSWR, low B+ voltage, high RF current, RF drive failure, external interlock or spark gap.

**SURGE PROTECTION BOARD.** An electrical panel that protects equipment from electrical surges in the ac power supply, antenna or site ground caused by lightning strikes.

**VSWR.** Voltage standing wave ratio. This is an expression of the ratio of forward voltage to reverse voltage on the feedline and antenna system. An ideal VSWR of 1:1 provides maximum transmitter-antenna efficiency.



## **NX200 PRE-INSTALLATION MANUAL**

Document: NHB-NX200-PRE

Issue: 3.0 2012-11-01

### **Nautel Limited**

10089 Peggy's Cove Road  
Hackett's Cove, NS Canada B3Z 3J4

Toll Free: +1.877.6NAUTEL (662.8835)  
(Canada & USA only) or

Phone: +1.902.823.3900 or

Fax: +1.902.823.3183

### **Nautel Inc.**

201 Target Industrial Circle  
Bangor, Maine USA 04401

Phone: +1.207.947.8200

Fax: +1.207.947.3693

### **Customer Service (24-hour support)**

+1.877.628.8353 (Canada & USA only)

+1.902.823.5100 (International)

Email: [support@nautel.com](mailto:support@nautel.com)

Web: [www.nautel.com](http://www.nautel.com)

© Copyright 2013 NAUTEL. All rights reserved.

