



# NX200 Main-Standby Transmitter Systems

All India Radio (AIR)  
Common Sites

## **Installation and Operation Manual**

Issue 0.3 .....28 October 2014

Nautel Limited  
10089 Peggy's Cove Road,  
Hackett's Cove, NS, Canada B3Z 3J4  
T.+1.902.823.3900 F.+1.902.823.3183  
info@nautel.com

U.S. customers please contact:  
Nautel Inc.  
201 Target Industrial Circle, Bangor ME 04401  
T.+1.207.947.8200 F.+1.207.947.3693  
info@nautel.com

e-mail: support@nautel.com  
www.nautel.com



# Warranty

by Nautel Limited/Nautel Inc. (herein after referred to as Nautel)

---

Nautel Limited/Nautel Incorporated, hereinafter referred to as Nautel, guarantees all mechanical and electrical parts of the equipment for a period of **18 months from date of shipment and 12 months from date of commissioning**.

1. A "Part Failure" shall be deemed to have occurred when the part has become defective, or does not have the characteristics required for the specified equipment performance:
  - (a) When the equipment is operated within the design parameters, and
  - (b) When the equipment is installed and adjusted according to Nautel's prescribed procedures as stated in the instruction manual.
2. Nautel shall provide replacements for all "Parts" at no cost to the Customer when they become defective during the warranty period, and upon the return of the defective part.
3. In the event that a "Part" fails during the warranty period and causes damage to a sub-assembly that cannot be readily repaired in the field, the entire sub-assembly so damaged may be returned to Nautel for repair. The repairs will be made without charge to the Customer.
4. Where warranty replacements or repair are provided under items 2 or 3, Nautel will pay that part of the shipping costs incurred in returning the part/assembly to the Customer.
5. Warranty replacement parts and repair, which are provided under items 2 or 3, shall be guaranteed for a period of ninety days from date of shipment or until the end of the original warranty period, whichever occurs later.
6. Nautel will not assume responsibility for any charges incurred by other than Nautel employees.
7. Nautel shall have the privilege of investigating whether failures have been caused by factors beyond its control.
8. Nautel shall in no event be liable for any consequential damages arising from the use of this equipment.
9. When requesting a warranty repair/replacement, please provide complete and accurate information. Observe the instructions regarding 'Equipment Being Returned to Nautel' on page two of this warranty and provide the information requested.
10. When ordering spare/replacement parts, please provide complete and accurate information. Refer to the parts list of the Repair manual for ordering information. Provide as much of the information requested for 'Equipment Being Returned to Nautel' on page two of this warranty as is practical. The information identified by an asterisk is the minimum required.

Nautel Limited  
10089 Peggy's Cove Road  
Hackett's Cove NS Canada B3Z 3J4  
T. +1.902.823.3900 F. +1.902.823.3183  
24hr. Answering Service 1.902.823.3900

Nautel Inc.  
201 Target Industrial Circle  
Bangor ME USA 04401  
T. +1.207.947.8200 F. +1.207.947.3693

## Customer Service Notice

A 'Technical Assistance' and 'Plug-in Module Exchange' service is available to Nautel users.



# Factory Support

## TECHNICAL ASSISTANCE

The Nautel field service department provides telephone technical assistance on a 24 hour, seven days a week basis. Requests by other media (facsimile or e-mail) will be responded to the next working day if received after Nautel's normal working hours. Contact the appropriate field service centre from the following:

U.S.A. customers use:	Nautel Incorporated 201 Target Industrial Circle Bangor, Maine 04401	Telephone Facsimile	207-947-8200 (24 hours) 207-947-3693
All other customers use:	Nautel Limited 10089 Peggy's Cove Road, Hackett's Cove, NS, Canada B3Z 3J4	Telephone Facsimile E-Mail Web	902-823-3900 (24 hours) 902-823-3183 support@nautel.com www.nautel.com

## MODULE EXCHANGE SERVICE

In order to provide Nautel customers with a fast and efficient service in the event of a problem, Nautel operates a factory rebuilt, module exchange service which takes full advantage of the high degree of module redundancy in Nautel equipment. This module exchange service is operated from Nautel's factory in Bangor, Maine and Hackett's Cove, Nova Scotia. These two locations allow us to provide a quick turn around service to keep our customers on the air. During the transmitter's warranty period, up to thirteen months from shipment, repair and exchange of modules is at no charge to the customer. When the warranty has expired, a charge of 80% of the list price for all exchanged modules is made. If the faulty module is returned to Nautel within 30 days, a credit is issued reducing this charge by one half to 40% of the list price. U.S.A. customers are required to contact our Bangor, Maine facility. Canadian and overseas customers should contact our Nova Scotia, Canada facility.

## EQUIPMENT BEING RETURNED TO NAUTEL

For all equipment being returned to Nautel and all requests for repairs or replacements:

Obtain an RMA number from Nautel (you must have an RMA number to return equipment)

Mark the item as 'field return'

Mark the item with the RMA number assigned by Nautel

Address the item to the appropriate Nautel facility

Complete and accurate information regarding the equipment being returned will ensure prompt attention and will expedite the dispatch of replacements. Refer to the nameplate on the transmitter and/or the appropriate module/assembly to obtain name, type, part and serial number information. Refer to the parts list of this manual or the appropriate service instruction manual for additional ordering information.

The following information should accompany each request:

- \* Model of Equipment
- \* Serial number of Equipment
- \* Name of Part/Assembly
- Serial number of Part/Assembly
- \* Complete reference designation of Part/Assembly
- \* Nautel's part number of Part/Assembly
- \* OEM's part number of Part/Assembly
- Number of hours in Use
- Nature of defect
- \* Return shipping address

\* Denotes minimum information required to order spare/replacement parts



# Safety

## Symbols

General definitions of safety symbols used on equipment or in manuals.



### **DANGER – HIGH VOLTAGE**

Indicates dangerous voltages (in excess of 72 volts), capable of causing a fatal electrical shock, are present on or near parts bearing this label.

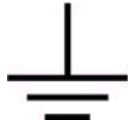

### **GROUND (EARTH)**

Used with wiring terminals to indicate the terminal must be connected to earth ground before operating equipment. If power is supplied without grounding the equipment, there is a risk of receiving a severe or fatal electrical shock. Also used on electrical schematics to indicate a part that is connected to earth ground.



### **GROUND (PROTECTIVE or SAFETY)**

Used with protective (safety) conductor terminals to indicate the terminal must be connected to ground before operating the equipment. If power is supplied without grounding the equipment, there is a risk of receiving a severe or fatal electrical shock.



### **ELECTROSTATIC SENSITIVE**

Indicates part or assembly is or contains devices that are electrostatic sensitive. To prevent damage to these devices, ensure the handling procedures outlined in this manual are observed.

### WARNING

A WARNING denotes a hazard. It identifies an operating procedure, condition, etc. which, if not strictly observed or adhered to, could result in injury or death to personnel. Throughout the technical manual, a WARNING shall immediately precede the text to which it applies.

### CAUTION

A CAUTION denotes a hazard. It identifies an operating procedure, condition, etc., which, if not strictly observed or adhered to, could result in damage to, or destruction of the equipment. Throughout the technical manual, a CAUTION shall immediately precede the text to which it applies.

### NOTE

A NOTE denotes important information pertaining to an operating procedure, condition, statement, etc., which is essential to highlight. A NOTE may precede or follow the text to which it applies.



## Toxic Hazard Warning

There may be devices used in this equipment containing beryllium oxide ceramic, which is non-hazardous during normal device operation and under normal device failure conditions. If applicable these devices are specifically identified in the equipment manual's parts list(s).

**DO NOT** cut, crush or grind devices because the resulting dust may be **HAZARDOUS IF INHALED**. Unserviceable devices should be disposed of as harmful waste.



# Contents

Page

1	GENERAL INFORMATION	
1.1	INTRODUCTION	1-1
1.2	PURPOSE AND SCOPE OF THIS MANUAL	1-1
	<b>1.2.1 Online Resources</b>	<b>1-2</b>
	1.2.1.1 Nautel User's Group	1-1
	1.2.1.2 Online Documentation	1-1
1.3	PURPOSE OF EQUIPMENT	1-1
1.4	MECHANICAL DESCRIPTION	1-2
1.5	TEST EQUIPMENT AND SPECIFIC TOOLS	1-3
1.6	GLOSSARY OF TERMS	1-3
1.7	FACTORY SUPPORT	1-3
2	PREPARATION FOR USE AND INSTALLATION	
2.1	INTRODUCTION	2-1
2.2	PRE-INSTALLATION REQUIREMENTS	2-1
	<b>2.2.1 Test Load and Dry Cooler - Pre-Installation Requirements</b>	<b>2-3</b>
	<b>2.2.2 Antenna Tuning Unit - Pre-Installation Requirements</b>	<b>2-7</b>
	<b>2.2.3 Ac Power System - Pre-Installation Requirements</b>	<b>2-7</b>
	<b>2.2.4 4-Port Switch, Controller and IMU - Pre-Installation Requirements</b>	<b>2-9</b>
	<b>2.2.5 RF Coaxial Transmission Line - Pre-Installation Requirements</b>	<b>2-13</b>
	<b>2.2.6 Ventilation System - Pre-Installation Requirements</b>	<b>2-17</b>
	<b>2.2.7 Lightning Protection</b>	<b>2-21</b>
	2.2.7.1 Antenna Feed Cable	2-21
	2.2.7.2 Antenna Tower	2-21
	2.2.7.3 External Control/Monitor Wiring	2-21
	<b>2.2.8 Modulating Audio</b>	<b>2-21</b>
	<b>2.2.9 Safety Interlocks</b>	<b>2-21</b>
	2.2.9.1 External Electrical System Interlock	2-22
	2.2.9.2 Mechanical Safety Interlock (Key Sequence System)	2-22
	<b>2.2.10 Remote Control Circuits</b>	<b>2-22</b>
	<b>2.2.11 Remote Status Indications</b>	<b>2-22</b>



# Contents

Page

2	PREPARATION FOR USE AND INSTALLATION (continued)	
2.3	INSTALLATION TASKS	2-23
2.3.1	Accepting the Shipment	2-23
2.3.2	Unpacking Instructions	2-24
2.3.3	Visual Inspection	2-24
2.3.4	Cabinet Pre-Positioning	2-25
2.3.5	Not Used	
2.3.6	Assembling the Main-Standby Transmitter System	2-25
2.3.7	Test Load and Dry Cooler - Installation Tasks	2-27
2.3.8	ATU- Installation Tasks	2-33
2.3.9	Ac Power Components - Installation Tasks	2-37
2.3.9.1	Not Used	
2.3.9.2	Ac Breaker Panel	2-39
2.3.9.3	Ac Wiring Cable Trays	2-43
2.3.9.4	Primary Ac Wiring	2-43
2.3.9.5	Secondary Ac Wiring	2-49
2.3.9.6	Other Ac Wiring	2-51
2.3.10	4-Port Switch, Controller, IMU - Installation Tasks	2-57
2.3.11	Transmission Line - Installation Tasks	2-65
2.3.12	Ventilation (Air Handling) System - Installation Tasks	2-71
2.3.13	Miscellaneous Installation Tasks	2-79
2.4	KEY SEQUENCE SYSTEM	2-80
2.5	COMMISSIONING AND OPERATION	2-83
2.5.1	Precautions to Observe	2-83
2.5.2	Preliminary Settings	2-83
2.5.3	Initial Operation	2-84





List of Figures		Page
1-2	Site Layout - NX200 Main-Standby Transmitter System (Example)	1-5
2-1	Partial Top View of NX200 System (201-1321-01;Common, showing Soda Load Kit (228-8305-02)	2-5
2-2	Not Used	
2-3	Assembly/Dimensional Information - 4-Port Switch for NX200 systems	2-11
2-4	Assembly/Dimensional Information - IMU for all Transmitter systems	2-12
2-5	NX200 (Common) Main-Standby System Transmission Line Layout (Nautel Part # 228-8307-01)	2-15
2-6	NX200 (Common) Main-Standby System Ventilation Layout	2-19
2-7	Air Handling Process for NX Main-Standby Transmitter Systems	2-20
2-8	Lifting the Dry Cooler (shown in shipping crate)	2-28
2-9	2-1/2 Inch Plumbing Kit (228-8360-03) for Soda Load and Dry Cooler for NX200 systems (Common)	2-31
2-10	Wiring/Connection Information for Soda Load and Dry Cooler Wiring Kits	2-32
2-11	Antenna Tuning Unit - Ground Switch Views	2-35
2-12	Antenna Tuning Unit - Safety Screen Views	2-36
2-13	Not Used	
2-14	Terminating Teck 90 conductors	2-39
2-15	Assembly Details - Breaker Panel (UE183A) for NX200 Systems	2-41
2-16	Step-by-step instruction to install cable cleats	2-45
2-17	Arranging three-phase wires in cable cleats (NX300 system example shown)	2-46
2-18	Ac Disconnect Switch wiring connection (NX300 switch shown), door removed for clarity	2-47
2-19	NX Power Transformer Primary Terminals (H1, H2 and H3), access panel removed for clarity	2-48
2-20	NX Power Transformer Secondary Connections (NX300 transformer shown)	2-49
2-21	NX200 (Common) Mains Equipment - Primary (228-8322-01) and Secondary (228-8323-02) Wiring Kits	2-53
2-22	One-Line Diagram - NX200 Ac Power Distribution	2-54
2-23	Ac Wiring/Connection Information for NX200 Systems	2-55
2-24	Trip Circuit for Breaker Panel's Main Breaker	2-56
2-25	Interconnect Cable between 4-Port Switch and Controller	2-61
2-26	Control/Monitor Assembly (228-2100) User Interface	2-62
2-27	Electrical Schematic - NX Main-Standby Transmitter System	2-63
2-28	Electrical Schematic - Control/Monitor Assembly (228-2100)	2-64
2-29	Transmission Line - Box-line 4-ft Section Assembly (Nautel Part # 228-6040)	2-67
2-30	Transmission Line Box-line Elbow Assembly (Nautel Part # 228-6030)	2-68
2-31	Cutting and Installation Tips for Coaxial Hard-Line (indoor only)	2-69
2-32	Thermostat Wiring Diagram	2-73



List of Figures (continued)		Page
2-33	Example Photos of Transmitter Ventilation System	2-74
2-34	Not Used	
2-35	Hanging Vibration Isolator Assembly with Typical Installation Configuration (required for vibration and noise reduction)	2-76
2-36	Example of Using Tie-In Section to Fit Between Spiral and Square Ductwork	2-77
2-37	Typical Key Sequence Diagram for NX200 Transmitter Systems	2-82

List of Tables		Page
2-1	Recommended Tools, Equipment and Resources Required for Installation	2-2
2-2	Ventilation System Details	2-17
2-3	Nautel Supplied Kits for the NX200 Transmitter Systems	2-23
2-4	Specifications and Kits for the Soda Load and Dry Cooler for each NX System	2-27
2-5	Plumbing Kits for Soda Load and Dry Cooler for each NX System	2-29
2-6	ATU System Part Numbers	2-33
2-7	Specifications and Kits for the Ac Main Equipment for each NX System	2-37
2-8	4-Port Switch Kits and IMUs for each NX System	2-57
2-9	Nautel Supplied Transmission Line Kits	2-65
2-10	Nautel Supplied Ventilation Kits	2-71

## List of Appendices

A	System Installation Drawings
B	Soda Load and Dry Cooler
C	Antenna Tuning Unit
D	Ac Power
E	4 Port Switch / IMU
F	Transmission Line
G	Ventilation
H	DRM Components (includes electrical schematic of DRM cabinet)



## Release Control Record

Issue	Date	Reason
0.1	10 January 2014	Customized for NX200 AIR - common systems
0.2	22 July 2014	Added Appendix H – DRM Components
0.3	28 October 2014	Corrected warranty terms; removed Figure 2-34 (not used)





# NX200 Main-Standby Transmitter System INSTALLATION AND OPERATION MANUAL

## Section 1 **GENERAL INFORMATION**

---

### 1.1 INTRODUCTION

Each NX200 Main-Standby Transmitter System consists of two AM broadcast transmitters, a 4-port switch and a test load connected in a main-standby arrangement. This system allows one transmitter to act as the backup for the main transmitter in the event of a main transmitter failure. One transmitter (transmitter A) in the system is a Nautel NX200 transmitter (200 kW capable). The other transmitter is an existing on-site transmitter.

Detailed information unique to the main-standby system (i.e. site preparation, system installation, theory of operation, parts/wiring lists and electrical schematic/assembly detail drawings) is provided in this document and its various appendices. Refer to the *NX200 Transmitter* documentation suite for information specific to each NX200 transmitter.

### 1.2 PURPOSE AND SCOPE OF THIS MANUAL

This *NX200 Main-Standby Transmitter System Technical Instructions Manual* provides information for preparing for the delivery, operation and installation of the NX200 Main-Standby Transmitter system. This manual is intended for use by field technicians, site managers and installation planners.

#### 1.2.1 Online Resources

The Nautel website ([www.nautel.com](http://www.nautel.com)) provides useful resources to keep you up to date on your equipment.

#### NOTE

*From the Nautel website's main page, choose the product line that suits your equipment. If you select 'Radio Broadcast Communications' or 'Navigation and Communication', the next page contains a Nautel User's Group (NUG) link.*

#### **1.2.1.1 Nautel User's Group**

The website includes a special section that customers can log into in order to access the Nautel customer newsletter, product manuals, frequently asked questions (FAQ), information sheets, and information about field upgrades.

#### **1.2.1.2 Online Documentation**

The website's NUG section provides online access to all the documentation for your NX300 main-standby AM broadcast transmitter system. Documentation is provided in Acrobat (PDF) format. You can use the documentation online or print the sections that you need.

### 1.3 PURPOSE OF EQUIPMENT

The NX200 Main-Standby Transmitter system is intended to be used in conventional AM broadcasting stations. Remote control facilities are incorporated to allow unattended operation at a transmitter site, remotely located from station studios.



## 1.4 MECHANICAL DESCRIPTION

See Figure 1-1. Appendix A contains complete system layout drawings for the transmitter site.

Each transmitter system consists of a Nautel NX200 Transmitter (Transmitter A - Unit 1), the existing on-site transmitter (Transmitter B - Unit 2) a control/monitor DRM cabinet (A1), an impedance matching unit (A2), a 4-port switch (A3), an antenna tuning unit (ATU) (A4), a test load (A5), a dry cooler and a control/monitor assembly.

Refer to the NX200 Transmitter's documentation to identify the location of all electrical parts contained within transmitter A. Connections to the station antenna, test load, impedance matching unit, transmitters A and B and the 4-port switch are made via EIA connectors, mounted at the top of each unit.

Each NX200 Transmitter has an external power transformer cabinet.

Various kits are provided to aid in the installation of the transmitter system, including:

- **Ac Mains Kit:** contains all ac power related components such as breaker panel, ac disconnect switches, primary and secondary wiring and the cable tray sections that - when assembled - will be suspended above the main-standby transmitter system to facilitate the connection of ac power between the breaker panel, power transformer cabinet and transmitter.
- **Soda Load Kit:** contains a 120-ohm soda load, rated for the maximum output power of the transmitter system, and an associated dry cooler for the test load. The test load will be used during the commissioning and testing of the transmitter system. The kit also contains the necessary wiring, disconnect switch and plumbing to connect the test load to the system.
- **Transmission Line Kit:** contains all the necessary coaxial transmission line (rigid hardline or square box-line) that - when assembled - will be suspended above the main-standby transmitter system to facilitate the RF connections between the transmitters, impedance matching unit, 4-port switch, test load and antenna system.
- **Ventilation Kit:** contains the duct sections that - when assembled - will be suspended above the main-standby transmitter system to facilitate the heating and cooling requirement for the transmitter system room.
- **4-Port Switch Kit:** contains the main-standby contactor switch for the transmitter system and the control/monitor assembly that controls the switch position, as well as provides the wiring hub for the transmitters, test load and system interlocks. The control/monitor assembly is intended for mounting in a 19-inch cabinet, in close proximity to the 4-port switch.
- **Impedance Matching Unit (IMU):** matches the impedance of the NX200 Transmitter's RF output from 50 ohms to 120 ohms for proper antenna operation. Positioned between the NX200 Transmitter's RF output and the 4-port switch.



- Antenna Tuning Unit (ATU): interfaces between the selected transmitter's 120-ohm output and the antenna input. There are two manually activated ground switches to allow grounding of the open line center conductor and the open bus to the antenna tower. These ground switches are part of the mechanical safety interlock system (see 2.4). The ATU is intended for installation in a user-provided shelter (hut), which is outside the main transmitter system building. Refer to Appendix C for detailed information on the ATU.

#### 1.5 TEST EQUIPMENT AND SPECIFIC TOOLS

Refer to Section 2 of this manual and to the *NX Pre-Installation Manual* for the list of special tools and test equipment required.

#### 1.6 GLOSSARY OF TERMS

Refer to any of the NX manuals for the *Glossary of Terms* relevant to each transmitter.

#### 1.7 FACTORY SUPPORT

Nautel provides after sale factory support. Technical assistance is available on a 24 hours, seven days a week basis. A factory service facility for repair of modules/assemblies is also available. Please refer to the *Factory Support* portion of the *Warranty* pages at the front of this manual for additional information.







ITEMS SUPPLIED BY ALL INDIA RADIO		
ITEM	DESCRIPTION	QTY
AIR 1	DRY COOLER FOUNDATION	1
AIR 2	SUPPORT HANGERS/STANDS FOR CABLE TRAYS, 120 OHM BOXLINES IMU, CHANGEOVER SWITCH & 50 OHM HARDLINE	A/R
AIR 3	SUPPORTS FOR LOAD HEAT EXCHANGER PIPING	A/R
AIR 4	FLOOR DRAIN & 1135-1362 (250-350 GAL) CONTAINMENT UNDER SODA LOAD (SEE NOTE )	1
AIR 5	2630 H x 2360 W x 1065 D mm (75x75x6 mm) ANGLE IRON PLATFORM FOR IMU/CHANGEOVER SWITCH	1
AIR 6	ATU HUT (NOT SHOWN)	1

ITEMS SUPPLIED BY NAUTEL			
ITEM	DESCRIPTION	NAUTEL #	QTY
1	200 KW TRANSMITTER	NARA57B	1
2	SODA LOAD SYSTEM	228-8305-01	1
3	BREAKER PANEL	UE183	1
4	IMPEDANCE MATCHING UNIT	228-8050-1*	1
5	4 PORT SWITCH SYSTEM (CHANGE OVER SWITCH)	228-8306-01	1
6	DRM SYSTEM	228-8370	1
7	DUMMY LOAD HEAT EXCHANGER	228-8305-01 (UP138)	1
8	800A DISCONNECT SWITCH	228-8422	1
9	TRANSFORMER	207-8452-04	1
10	TRANSMISSION LINE KIT	228-8307-01	1
11	MAINS EQUIPMENT	228-8309-01	1
12	VENTILATION SYSTEM KIT	228-8311-02	1

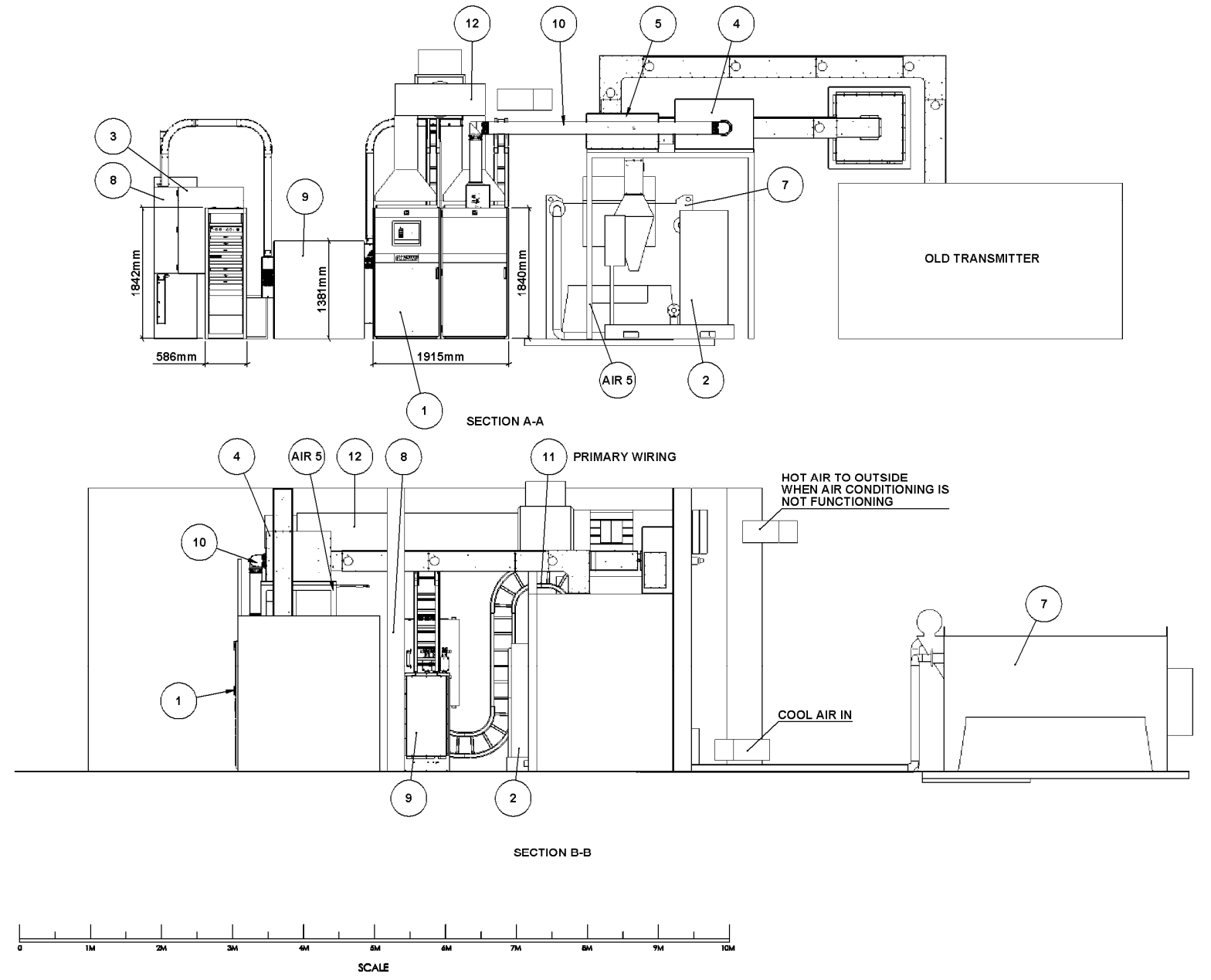
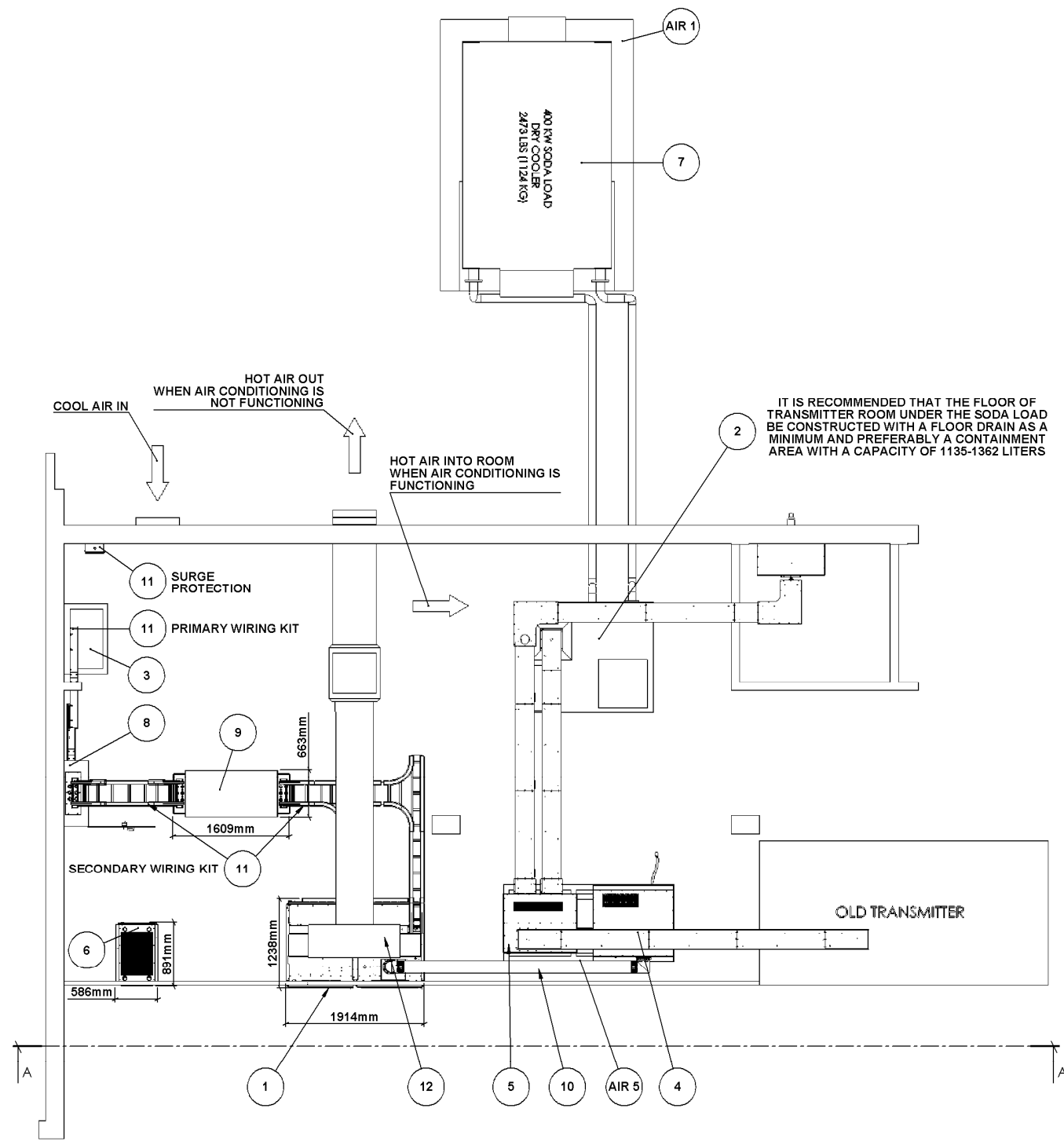

Dimensions = mm (inches)

# NX200 Main-Standby Transmitter System INSTALLATION AND OPERATION MANUAL

## Section 2 **PRE-INSTALLATION AND INSTALLATION**

---

### 2.1 INTRODUCTION

This section contains pre-installation and installation information for the NX200 main-standby transmitter system.

#### NOTE

*Failure to comply with recommendations and instructions in this section may void the manufacturer's warranty. Please review the Nautel warranty terms and conditions at the beginning of this technical manual.*

### 2.2 PRE-INSTALLATION REQUIREMENTS

Prepare the site to receive the transmitter system prior to its delivery and/or installation. Consider the following when preparing new sites and use it as the evaluating criteria at existing sites. Nautel recommends that you incorporate all requirements to ensure optimum reliability and performance.

Pre-installation considerations for the NX main-standby transmitter system are broken down into sections based on major components or sub-systems within the transmitter system. This section describes high-level system level pre-installation considerations and, in some cases, makes reference to the sub-system sections. After completing the tasks outlined in this section, proceed to the sub-system pre-installation considerations for more detailed information:

Table 2-1 lists the tools, equipment and resources you will need during installation.

(a) Review the pre-installation requirements for each sub-system kit (see reference paragraphs below).

- Test Load and Dry Cooler - see paragraph 2.2.1
- Antenna Tuning Unit - see paragraph 2.2.2
- Ac Power System- see paragraph 2.2.3
- 4-Port Switch and Impedance Matching Unit - see paragraph 2.2.4
- Transmission Line - see paragraph 2.2.5
- Ventilation - see paragraph 2.2.6
- Miscellaneous - see paragraph 2.2.7

(b) Clean and vacuum the transmitter system room prior to receiving the system.



Table 2-1: Recommended Tools, Equipment and Resources Required for Installation

Item/Resource	Application
Forklift, 2000 kg (4500 lb) capable	Mechanical assistance for moving heavy system crates; positioning heavy components such as NX200 transmitter, transformers, ATU, soda load, dry cooler.
Skyjack, 250 kg (550 lb) capable	Mechanical assistance for lifting elevated items into place such as cable tray, transmission line, ventilation ducts, 4-port switch, IMU, etc.
Licensed electrician	To safely plan and install ac wiring and cable tray system. Schedule accordingly.
Licensed plumber	To plan and install plumbing between the soda load and dry cooler. See Soda Load Kit - Pre-installation Considerations and Installation Instructions for more information. Schedule accordingly.
Licensed ventilation technician	To plan and install the ventilation system that moves the exhaust air from the transmitter output to the transmitter room or outside of the building. See Ventilation Kit - Pre-installation Considerations and Installation Instructions for more information. Schedule accordingly.
Pipe threader	To thread any pipe sections provided with the Plumbing Kit.
Support Structures	The end user must provide a means to support various system components, including the impedance matching unit (IMU), 4-port switch, all ventilation ducting, all coaxial transmission line and all ac cable tray sections. It is the responsibility of the end user to ensure these floor-mounted support structures do not infringe on the clearance requirements of the transmitter components that are installed on the floor of the transmitter building.
Pipe cutters	To trim the inner and outer conductors of 6-1/8 inch RF coaxial hardline.
Deburring tool and Scotch Bright pads	To clean up the cut ends of RF coaxial hardline.
Standard hand tools	Miscellaneous tool kit including various screwdrivers (Phillips, flat, etc.), nutdrivers, metric wrench set, pliers, wire-cutters, etc.



## 2.2.1 Test Load and Dry Cooler - Pre-installation Requirements

### Appendix References:

- Appendix A
  - Appendix B
- (a) Ensure a floor drain (as a minimum) and preferably a containment area is available to handle any possible fluids from leakage in the soda load or associated plumbing. The containment area should have 250 to 300 gallon (1135 to 1362 L) capacity.
  - (b) Nautel recommends that the floor under the soda load be reinforced concrete (see Figure 2-1 for details).
  - (c) Obtain a supply of distilled water (approximately 140 US gallons) for the soda load.
  - (d) Build a foundation for the dry cooler (see Figure 2-1 for details). To allow filling and air bleeding of the soda load to dry cooler plumbing, ensure the foundation is the same elevation or higher than the soda load's base.
  - (e) Obtain a supply of potable water (approximately 100 US gallon and piping) for the dry cooler. **NOTE:** Nautel provides glycol (part # UE149) to serve as part of this mixture. When preparing amounts, plan for 70% potable water and 30% glycol.
  - (f) Clean and inspect the areas where the soda load and dry cooler will be installed, noting the soda load is intended for installation inside the main transmitter building and the dry cooler is intended for installation outside the building.





**Pre-installation Requirements:**

Plumbing Kit - Schedule a plumber to install the Nautel provided kit. Ensure a pipe threader is available.

**Pre-installation Requirements:**

Floor capability - Nautel recommends the floor under the soda load be constructed of 100 mm (4 in.) reinforced concrete having at least 3000 psi compressive strength at 28 days after pouring.

Drain - Plan a floor drain (as a minimum) and a containment area (recommended) with a 250 - 300 gallon (1135 - 1362 L) capacity.

Resistive Fluid - obtain 140 g distilled water

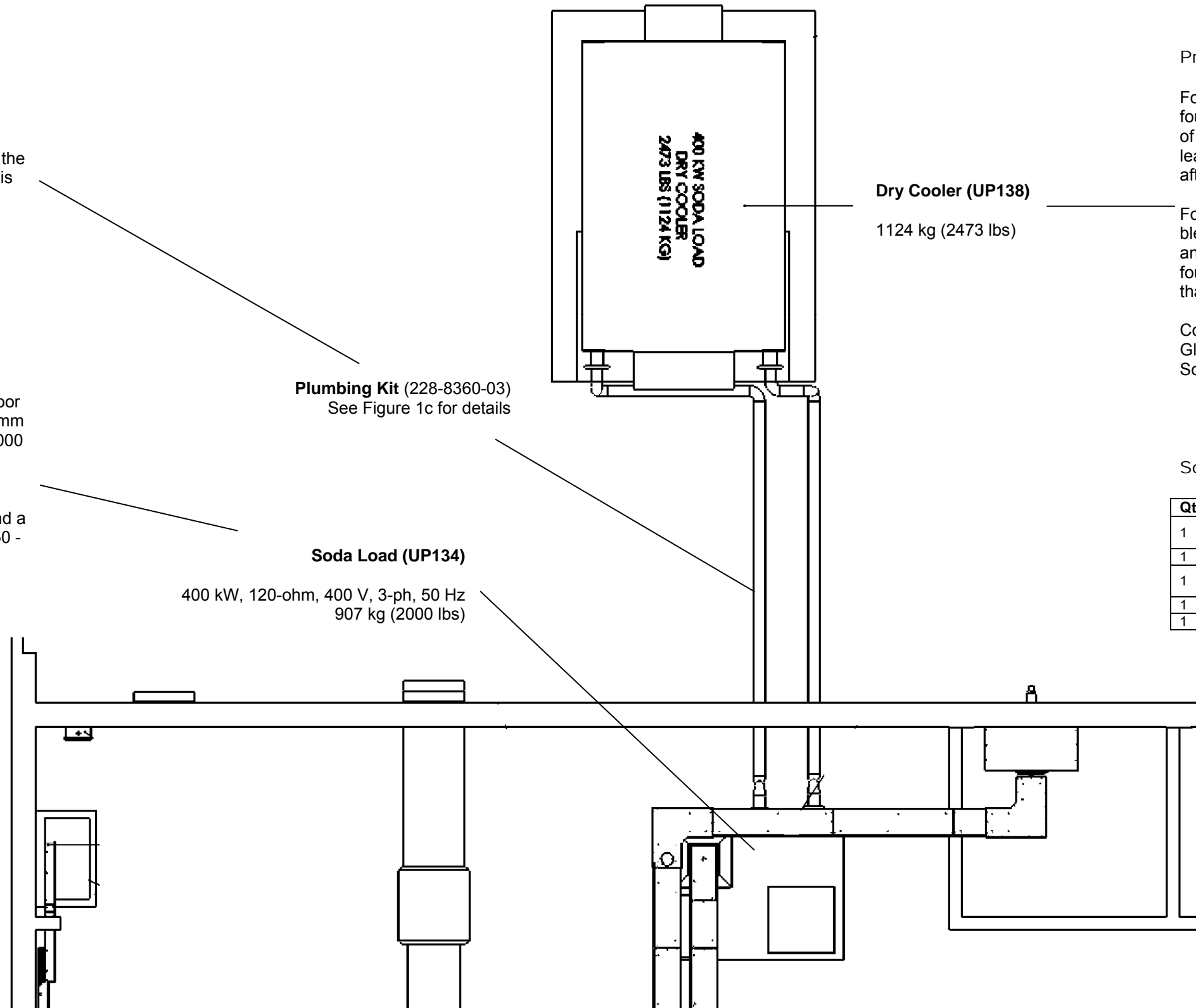

**Pre-installation Requirements:**

Foundation capability - Nautel recommends the foundation be 100 mm (4 in.) thick constructed of reinforced air entrained concrete having at least 3000 psi compressive strength at 28 days after pouring.

Foundation elevation - to allow filling and air bleeding of the plumbing between the dry cooler and the soda load, ensure the dry cooler foundation is the same elevation as or higher than the soda load base.

Cooling Loop-- obtain a supply of potable water. Glycol (Nautel Part # UE149) is provided. Solution should be 30% glycol, by weight.

**Soda Load Kit 228-8305-01 Contents:**

Qty	Part #	Description
1	UP134	Soda Load, 400 kW, 120-ohm, 400 V, 3-ph, 50 Hz, incl. cooling unit
1	228-8321	Soda Load Wiring Kit, NX200/NX300
1	228-8360-03	Plumbing Kit for UP134 (2-1/2"), Common
1	228-8320	Dry Cooler Wiring Kit, NX200/NX300
1	UP138	Dry Cooler for UP134



Partial Top View of NX200 System (201-1321-02; Common), showing Soda Load Kit 228-8305-01

### 2.2.2 Antenna Tuning Unit - Pre-installation Requirements

This section contains pre-installation information applicable to the use of custom Kintronics Laboratories supplied antenna tuning unit (ATU). The following information is relevant to all of the systems covered by this handbook except if noted.

#### Appendix References:

- Appendix C
- (a) Ensure that sufficient space is made available for the assembly and installation of site specific ATU and associated ATU hut (weather shelter). Clean and inspect the area where the ATU hut and ATU will be installed.
- (b) Make sure the following tools are available to perform ATU installation:
- Standard hand tools
  - Duct tape or similar adhesive tape, for securing the floor layout panels
  - 1/8" (or closest metric equivalent) masonry drill bits, suitable for drilling into concrete or similar material
  - 5/16" (or closest metric equivalent) masonry drill bits
  - Vacuum cleaner for cleaning out drilled holes in concrete.
  - Hardware anchors suitable for use with concrete or similar, as appropriate for the actual construction material used to construct the Tuning Houses.
  - Standard-sized Allen wrench set.

### 2.2.3 Ac Power System - Pre-installation Requirements

The system requires a user-provided 400 V ac mains connection to the breaker panel.

#### Appendix References:

- Appendix A
  - Appendix D
- (a) Obtain and install new ground rods and radials, as required. See sheet 6 (Earthing) of the transmitter system's layout drawings in Appendix A for suggested locations of ground rods.







2.2.4 4-Port Switch, Controller and IMU- Pre-installation Requirements  
Nautel provides the 4-port switch, control/monitor assembly, IMU, and all interconnect wiring and transmission line for each system. Prepare each site for installation of these items as follows:

Appendix References:

- Appendix A
  - Appendix E
- (a) Build a support structure for the 4-port switch. See the Layout drawing in Appendix A and Figure 2-3 for switch weight, dimensions and height requirement.
- (b) Build a support structure for the IMU. See the Layout drawing in Appendix A and Figure 2-4 for IMU weight, dimensions and height requirement.

NOTE

*The IMU's support must be an open-framed structure to aid in the cooling of the IMU as well as providing access to the clearance hole in the bottom of the IMU for connection of transmission line. For NX200 systems, the IMU has cooling fans.*

- (c) Verify that the intended location for the control/monitor assembly (e.g., PIE cabinet) is in close proximity to the location of the 4-port switch. The control/monitor assembly is designed for mounting in a standard 19-inch rack opening. Nautel provides an interconnect cable for the 4-port switch and the control/monitor assembly, which is 25 ft in length.
- (d) If desired, prepare a system interlock circuit that, when connected to the system interlock on the rear of the control/monitor assembly, will allow safe enabling and disabling of RF output power for the transmitter system. An optional 'customer interlock' circuit is also available.





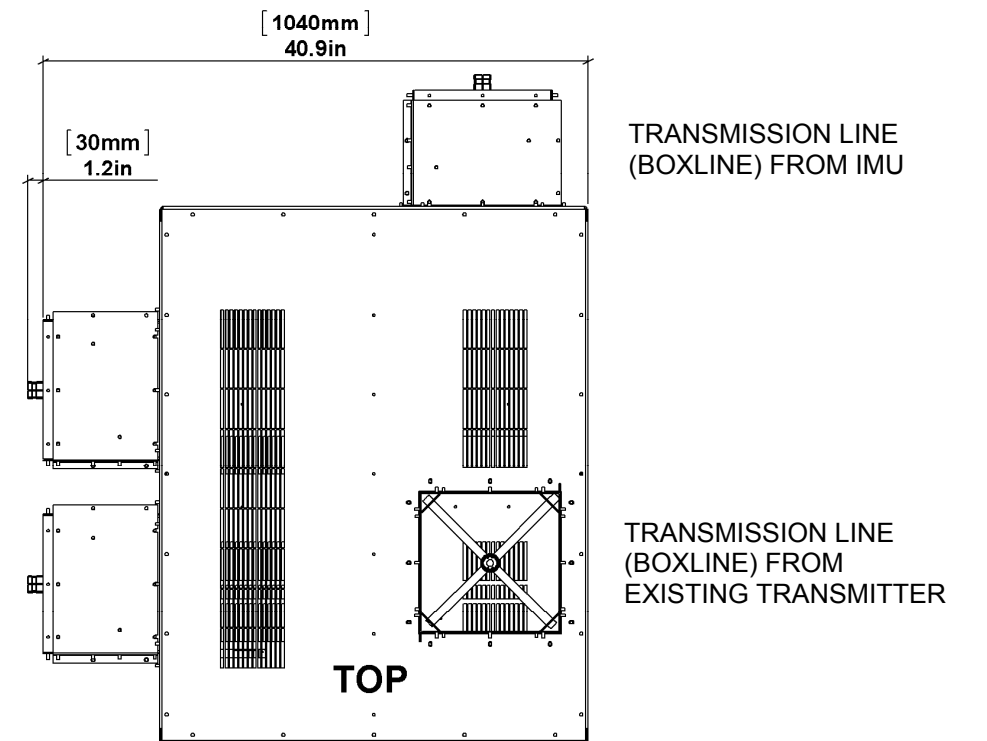
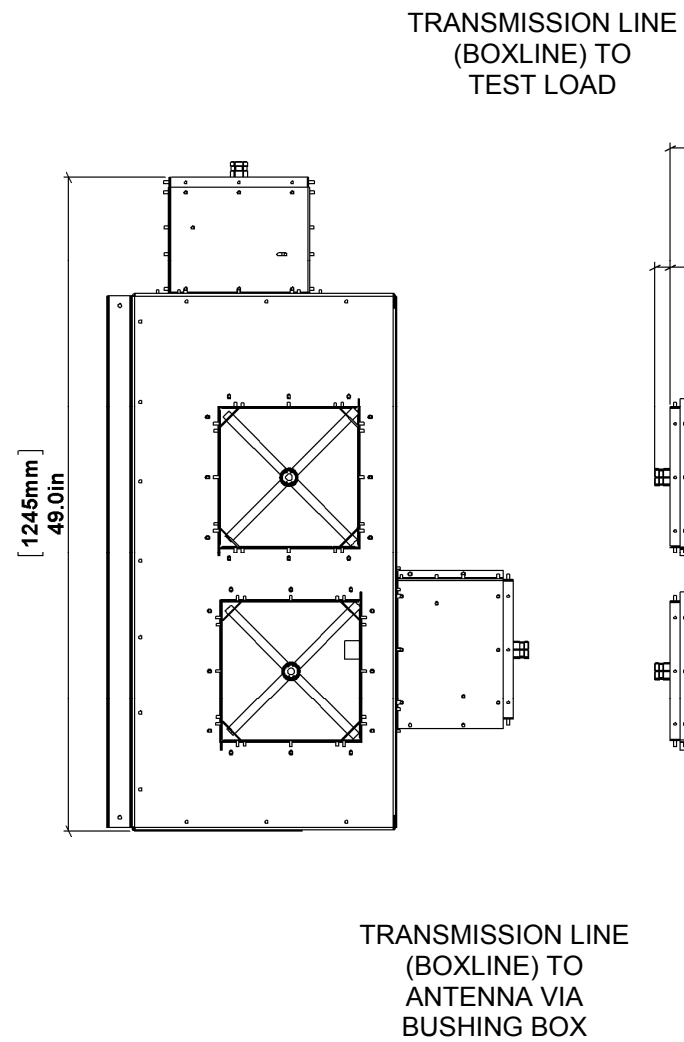
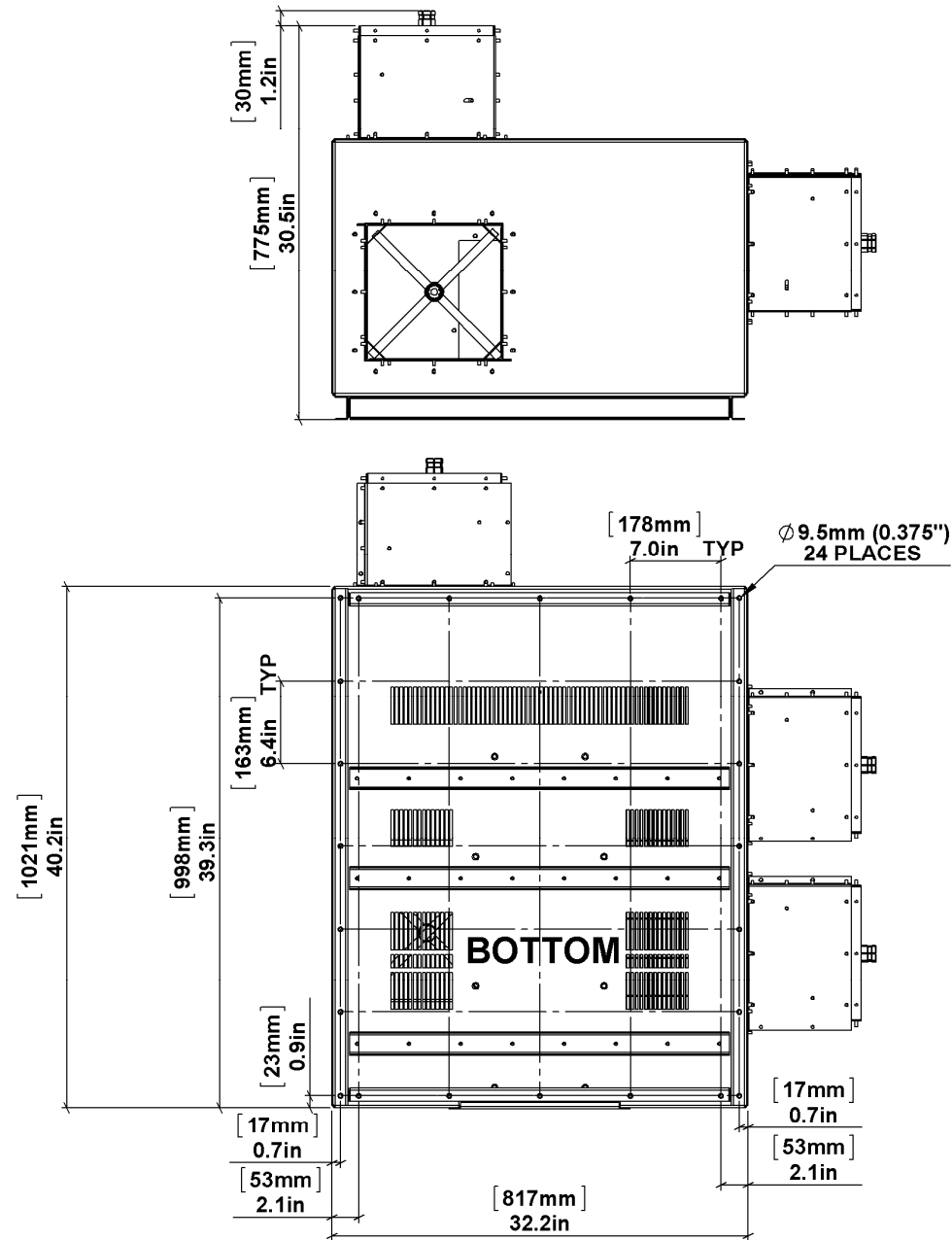

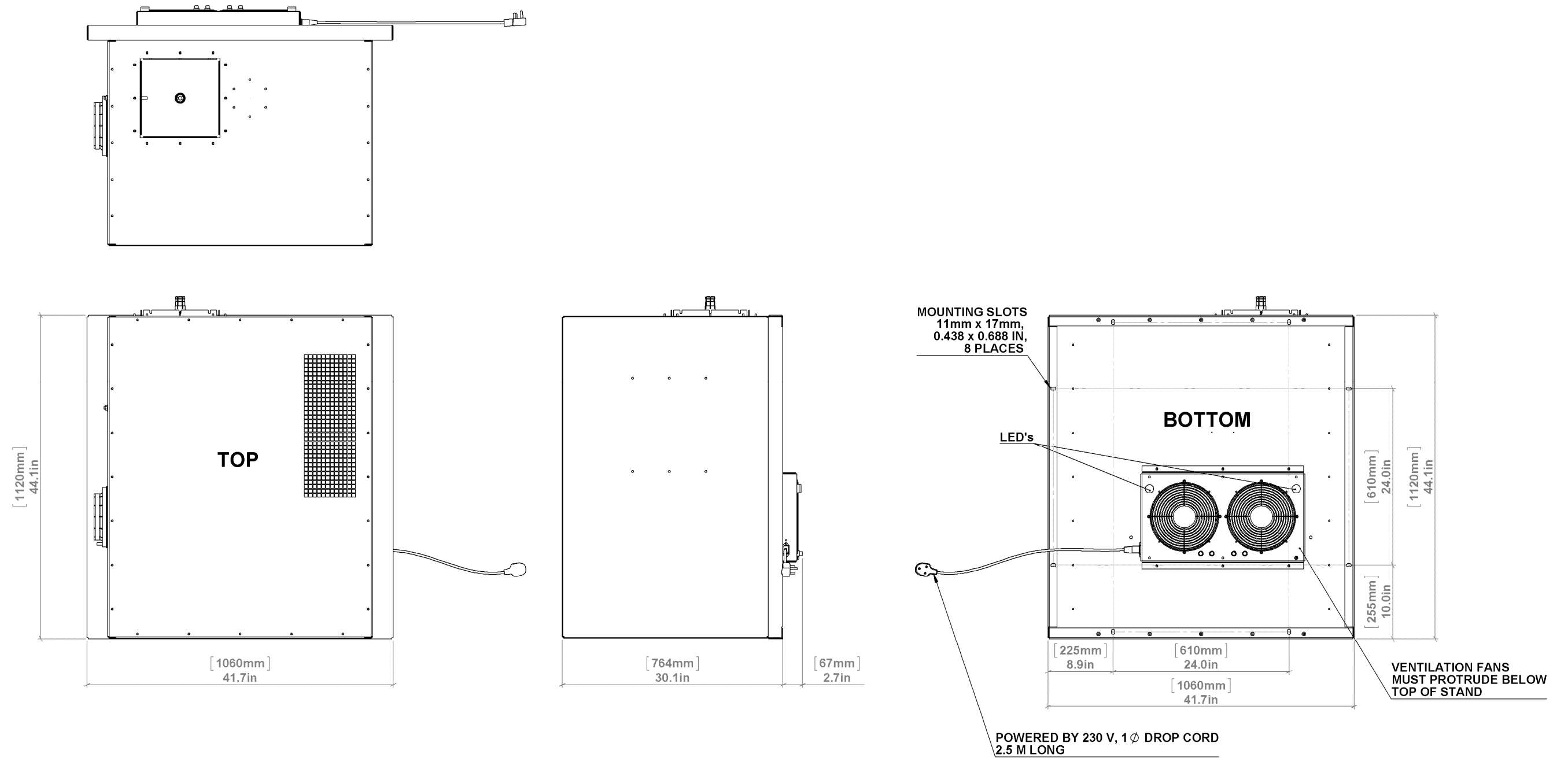

### 2.2.5 RF Coaxial Transmission Line - Pre-installation Requirements

This section contains pre-installation information applicable to the use of Nautel supplied transmission line kits (box-line and rigid line) for each transmitter system. The following information is relevant to all of the systems covered by this handbook except where noted.

#### Appendix References:

- Appendix A
  - Appendix F
- (a) Ensure that sufficient space is made available for the assembly and installation of site specific rigid line and box-line sections, as applicable.
- (b) Prepare a suitable hole in the wall to support the RF output bushing box, provided by Nautel. See the System Layout Drawings in Appendix A and Figure 2-5 for details.
- (c) Build support structures for the transmission line sections, which should be ready for use during installation. See the Layout drawing in Appendix A and Figure 2-5 for weights, dimensions and height requirements, noting:
- 6-1/8-inch or 3-1/8-inch rigid line (transmitter to IMU) is 10 kg (22 lbs)/m
  - Box-line: (various connections see Figures 2-5) 4.5 kg (10 lbs) per 1.2 m (4 ft) sections. Elbow sections are also 4.5 kg (10 lbs) per section.

#### NOTE

*Plan the installation of your transmission line system according to the system layout drawings provided. The position and height of system components such as the transmitters, IMU, 4-port switch and RF output bushing box are critical in determining the height of transmission line support structures.*

- (d) Make sure a set of standard hand tools is available to perform transmission line installation.





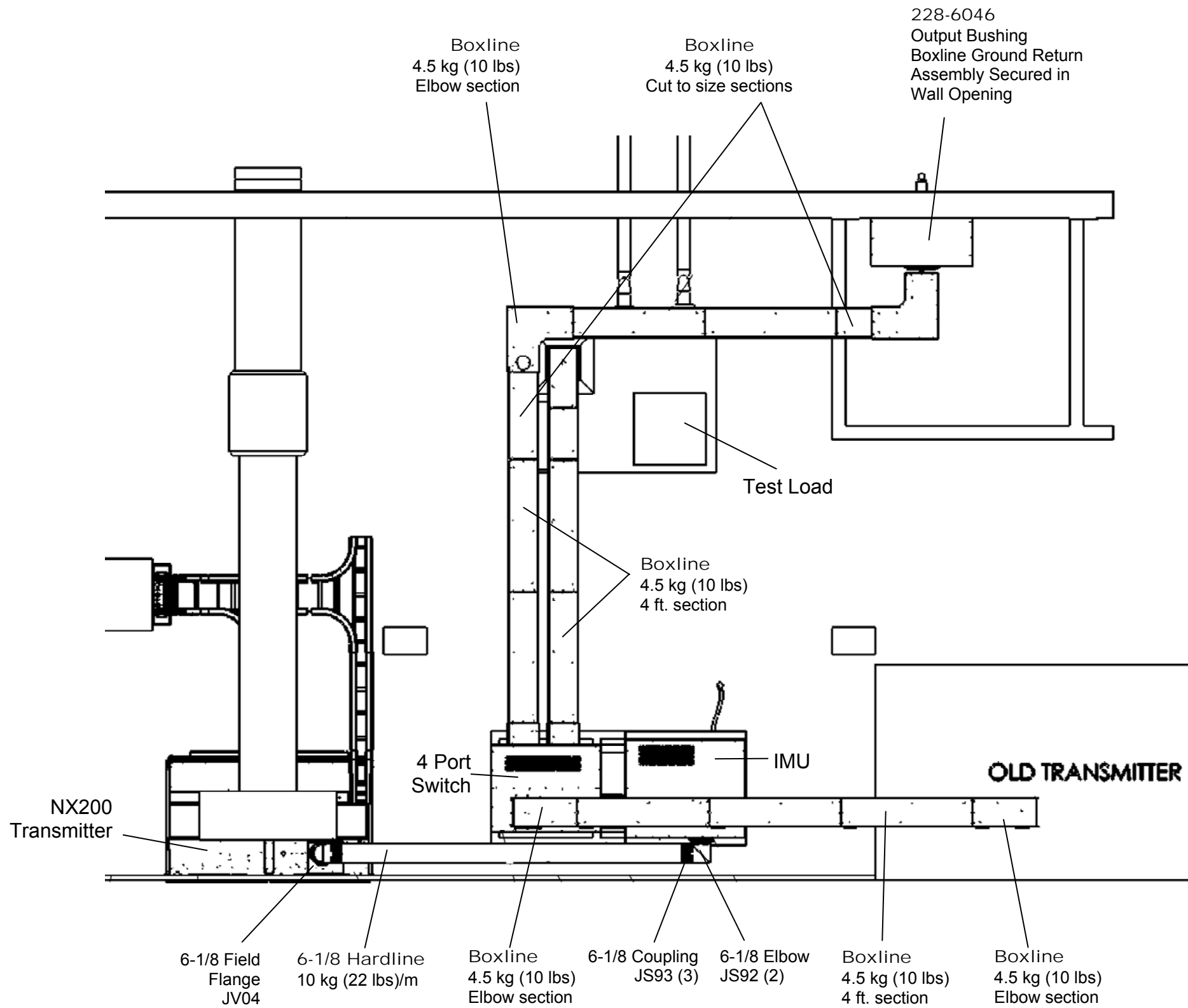

Transmission Line Kit (Nautel Part # 228-8307-01):

Qty	Part #	Description
1	228-8520-01-P	HARDLINE KIT, 6-1/8", NX200,INDIA
1	JV04	CONN, FLANGE, FIELD, 6 1/8 EIA
1	JS90	CONN, INNER, MALE, 6-1/8"
2	JS92	CONN, COAX, 90 ELBOW, EQUAL,UNFLNGD, 6-1/8" EIA
3	JS93	CONN, COAX, COUPLING, 6 1/8,RIGID, INNER INCLUDED
20 FT	JS88	COAX, 6-1/8" RIGID LINE,UNFLNG BOTH ENDS
1	228-8308-P	BOXLINE KIT, 120 OHMS, INDIA
18	228-6040-P	BOXLINE 4 FT SECTION KIT (ITEMS NOT DETAILED)
8	228-6030-P	BOXLINE ELBOW KIT (ITEMS NOT DETAILED)
1	228-6046-P	OUTPUT BUSHING BOXLINE GROUND RETURN ASSY
1	228-6042	BOX LINE CUTTING KIT:
1	228-6041	BOX LINE DRILL JIG DETAIL ASSY
2	471-3	TWIST DRILLS
2	HY104	CLAMP, C, 1" X 1" CAST
1	HY105	HACKSAW, 12"
1	HY106	FILE, FLAT BASTARD, 6"
1	HY107	HACKSAW BLADE, 12"
4	228-6023-02	SODA LOAD TO BOXLINE MOUNTING BRACKET
100	HMN04	NUT, HEX, M5 X 0.8, SS
100	HMW34	WASHER, SPLIT, M5, SS
100	HMW04	WASHER, PLAIN, M5, SS
20	HMSP32F	SCREW,PAN,PHIL,M5X0.8X16LG,SSC/W SPLIT & FLAT



### 2.2.6 Ventilation System - Pre-installation Requirements

This section contains pre-installation information applicable to the use of Nautel supplied ventilation system kits for all main-standby transmitter systems. The following information is relevant to all of the systems covered by this handbook except where noted.

#### Appendix References:

- Appendix A
- Appendix G

- (a) Ensure that sufficient space is made available for the assembly and installation of site specific ventilation ducting sections.

#### NOTE

*With the assistance of a certified ventilation technician, plan the installation of your ventilation system according to the system layout drawings provided. The position of system components such as the NX200 Transmitter and intake/exhaust louvers are critical in determining the height of ventilation support structures.*

- (b) Prepare suitable holes in the wall to support the air intake/damp filter louver and the air exhaust (outlet) louver, provided by Nautel. See the System Layout Drawings in Appendix A, Table 2-2 and Figures 2-6 for details.

Table 2-2: Ventilation System Details

System	Part #	Intake Louver	Outlet Louver	Fan Specifications
NX200	UE185	60.96 x 60.96 cm	60.96 x 60.96 cm	4000 CFM, 1.5 hp, 400 V ac, 50 Hz, 3-ph

- (c) Build support structures for the ventilation sections and the exhaust fan, which should be ready for use during installation. See the Layout drawing in Appendix A and Figure 2-6 for weights, dimensions and height requirements, noting:
- 610 mm (24") square duct is 18 kg (40 lbs)/m
  - 6000 CFM exhaust fan is 219 kg (482 lbs); 4000 CFM is 125.6 kg (277 lbs), 2000 CFM is 98.8 kg (218 lbs). **NOTE:** The exhaust fan requires vibration isolators to dampen the vibration (noise) during operation. These isolators require special mounting methods. See Appendix G for more information.
  - Exhaust/return air dampers with exhaust louver is total 100 kg (220 lbs)
- (d) Make sure a set of standard hand tools is available to perform transmission line installation.
- (e) Consider the following for the air handling system, noting that the air handling system has been pre-planned and part of the air handling system is being provided by Nautel:





#### NOTE

The air handling system is configured with one (1) reverse thermostat and three (3) Belimo spring-return actuators to open and close control dampers to allow exhaust heat to be returned the transmitter room under normal air conditioned mode (thermostat temperature dependent). However, this warm air is exhausted out of the room when the air conditioning is not operating and the thermostat temperature exceeds 36°C (96.8°F). See Figure 2-7 for a linear depiction of this functionality.

- i. Air Temperature: Do not allow the transmitter room ambient air temperature to exceed 50°C (122°F) at sea level. Cooler temperatures are recommended in order to improve the reliability of the transmitter. At higher altitudes, derate the maximum inlet air temperature as follows:
  - De-rate the ambient temperature 3°C (5.4°F) per 500 m – or 2°C (3.6°F) per 1,000 feet above sea level.

**Example:** At 1600 m (1 mile) above sea level, maximum ambient temperature should not exceed 40.4°C (104.7°F).

Ensure that hot air from the transmitter is not drawn back into the transmitter's cool air intake.

#### NOTE

To see the cooling plant requirements for the NX200 transmitter, refer to the NX200 transmitter's Pre-installation Manual.

- ii. Calculating BTU Cooling Requirements: To determine the number of British thermal units (Btu) being generated per hour as waste heat, multiply the average RF output power (in watts) by 0.111 (the heat factor at rated power) and then multiply the product by 3.413.
- iii. Closed Loop or Forced Air Cooling Systems: Closed loop or forced air cooling systems can be used, so long as the air is well filtered to prevent dust and insects from entering the NX200 Transmitter, and so long as a minimum of 3,000 cubic feet per minute (CFM) (1,500 per cabinet) at 0.5 pounds per square inch (PSI) is supplied to the intake duct.
- iv. Heating: The transmitter room must contain a heating system that will ensure the ambient air temperature does not drop below 0°C (32°F).



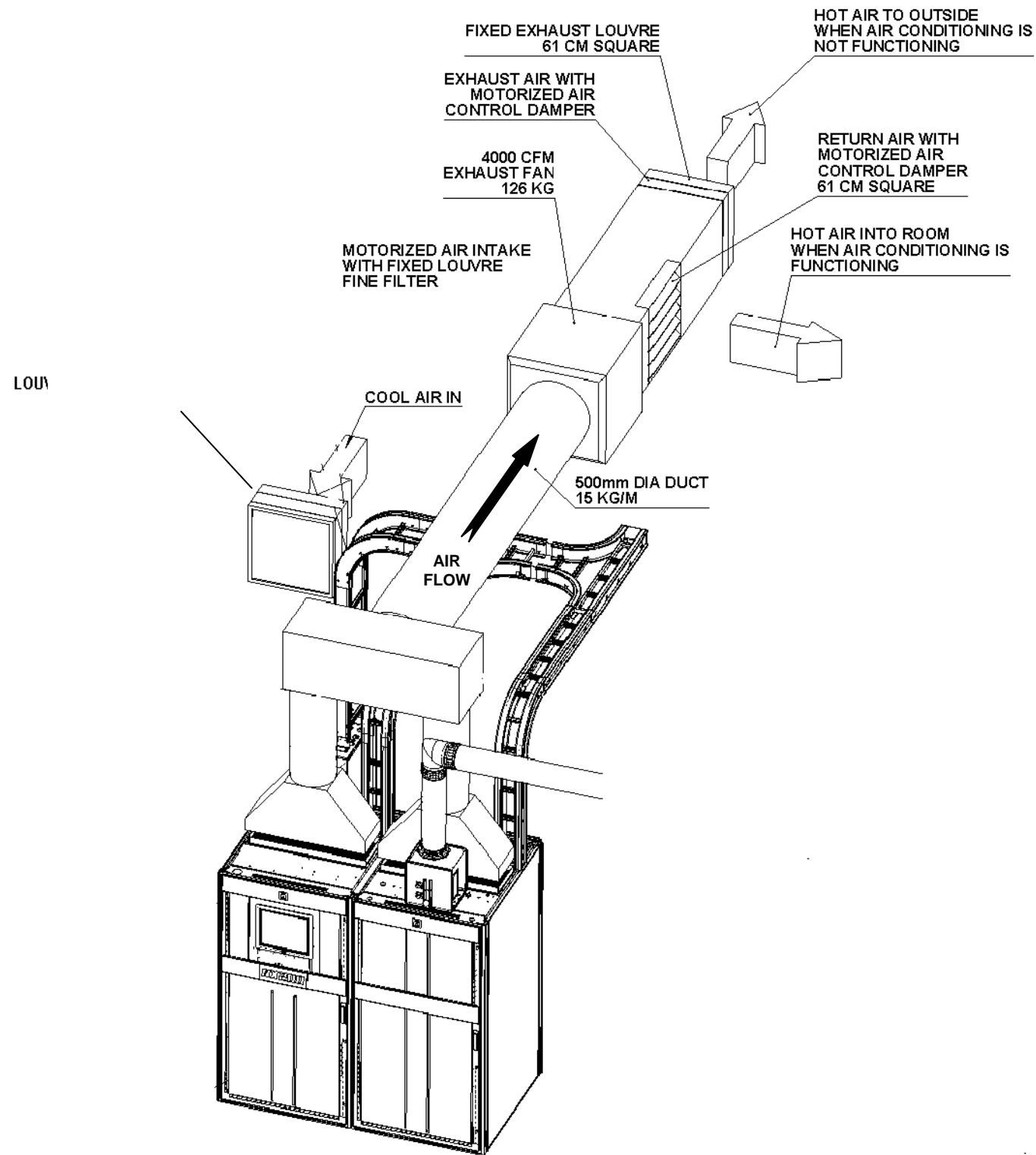

WALLS REMOVED FOR CLARITY

NX200 Ventilation System Kit (Nautel Part # 228-8311-02):

Qty	Part #	Description
1	UE184	Ventilation Kit, AIR, NX200 COMMON
1		4000 CFM EXHAUST FAN
30 FT		20" SPIRAL DUCTWORK
2		LENGTHS OF 12" DIA SPIRAL
2		35X14 TO 12" RD HOODS
		18"X18" DUCTWORK FOR HOOD TIE IN
2		12" DIA SIDE TAKE OFFS
		ALL FITTINGS AND CAVASS CONNECTIONS FOR FAN / MAIN DUCTWORK
		24"X24" EXHAUST LOUVER AND DAMPER
		24"X24" BY PASS DAMPER
1		24"X24" INTAKE LOUVRE
		DAMPER AND FILTER SECTION W/ REUSABLE FILTER
1		SPARE FAN MOTOR AND BELT
1		REVERSE ACTING THERMOSTAT
3		DAMPER MOTORS
		LAYOUT DWGS
1	228-8328	HVAC Wiring Kit, INDIA
100 FT	WG52	WIRE, TECK90, 10AWG, 3 STRAND+ #12AWG GROUND WIRE, 600V
4	HAA83	CONN, TECK, 3X10AWG, ALUMINUM
1	SA80	SWITCH, DISCONNECT, 63A, 3 POLE, ABS HOUSING, IP66
4	HAI69	NUT, ALUM, 1/2" CONDUIT
250 FT	WE58	WIRE, 18AWG, 2 COND, JACKETED, 90°C EPDM
8	HAA99	GRIP, CORD, 3/8, STRAIGHT, NON-METAL
8	HL52	NUT, 3/8 FOR LAPP 52138
4	HY110	BOX, JUNCTION, NON-METAL, 4"X4"X2", W/LID
10	HV46	CONNECTOR, 5 WIRE, 28-12 AWG, CONNECTOR, 5 WIRE, 28-12 AWG,



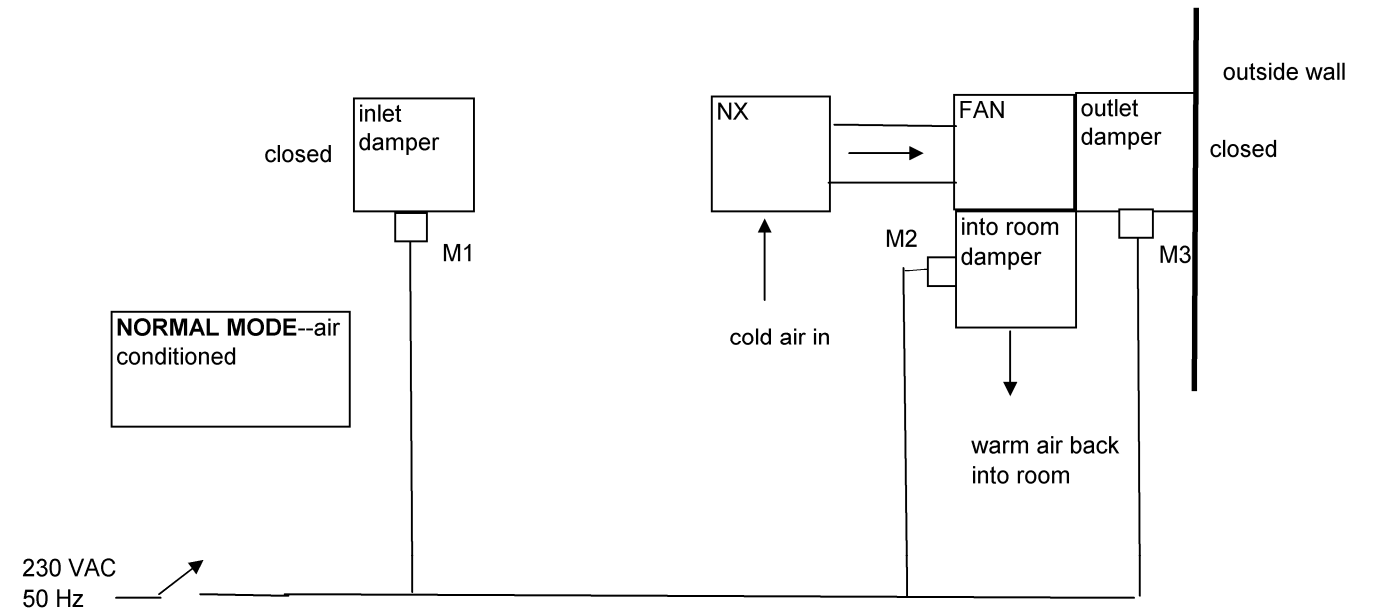

Thermostat open when cool.

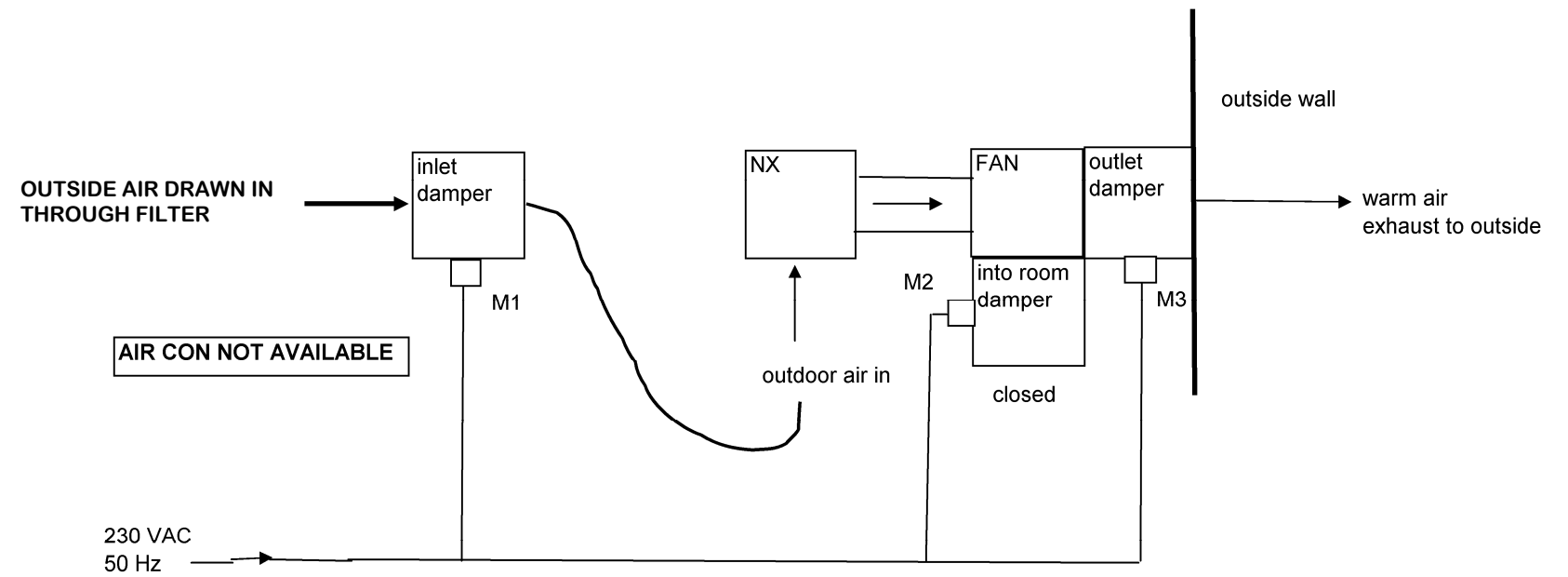

Thermostat closed when hot.

Truth Table for Damper Motors

Thermostat	Motors	M1	M2	M3
OPEN	NOT POWERED	CLOSED	OPEN	CLOSED
CLOSED	POWERED	OPEN	CLOSED	OPEN



### 2.2.7 Lightning Protection

Extremely high voltage/current transients are produced when a lightning strike occurs. These transients, which are typically the most significant hazard to any piece of solid state equipment, may be passed to the main-standby transmitter system through the wiring connection from a power source or antenna system. It is imperative that all practical precautions be taken to protect the main-standby cabinet and transmitters from this phenomenon. Refer to the *Lightning Protection* section of the Nautel *Recommendations for Site Preparation* booklet for recommendations and specific protection techniques. The following requirements are considered to be essential to this end.

#### NOTE

*The ac power source usually presents the lowest impedance path to ground potential for a lightning strike and will normally carry most of the lightning induced current away from the transmitter system site. When lightning hits the power source, a significant amount of induced current may flow towards the transmitters. In this instance, the objective is to route the current around the transmitter system, instead of through it, to the best ground available.*

#### **2.2.7.1 Antenna Feed Cable**

The shield of the antenna feed coaxial cable should be connected directly to the station reference ground, where it enters the building. In addition, if practical, the center conductor and the shield of the feed cable should pass through a ferrite toroid which is positioned between the shield ground, at the building entrance and the shield termination at the combiner cabinet. This toroid will be transparent to the RF signal, but will present high impedance to transients originating in the antenna.

#### **2.2.7.2 Antenna Tower**

The antenna tower is the most likely target for lightning strikes. It is imperative that it contain lightning strike protection devices, such as air-gap spark balls, as the first line of defence against these strikes.

#### **2.2.7.3 External Control/Monitor Wiring**

All external control/monitor wiring that may be subjected to lightning induced transients should be interfaced to the station reference ground by surge protection devices where they enter the building. In addition, all conductors and their shields should pass through a ferrite toroid which is positioned between its surge protection device and the main-standby cabinet and transmitters. This toroid will be transparent to control/monitor signals, but will present an impedance to lightning induced transients.

### 2.2.8 Modulating Audio

Modulating audio must be applied from an external source to each transmitter, via the program input equipment (PIE) cabinet, provided by Nautel. Refer to the *NX200 Transmitter Pre-installation Manual* for audio input specifications.

### 2.2.9 Safety Interlocks

There are two types of safety interlocks - electrical and mechanical. The electrical interlock is an external circuit that inhibits the RF output if any of its serially connected switches is opened. The mechanical interlock is a key controlled access system that prevents opening of panels that provide access to areas with high voltages when ac power is being applied.



### **2.2.9.1 External Electrical System Interlock**

See 4-port switch pre-installation requirements (paragraph 2.2.4) and installation tasks (paragraph 2.3.10) for details on interlock wiring.

### **2.2.9.2 Mechanical Safety Interlock**

The mechanical safety interlock system consists of locked panels in areas of the system that contain or may be subjected to life threatening voltages. A key controlled access system ensures a panel cannot be unlocked unless the ac power has been turned off and the antenna feed cable has been grounded. Conversely, it ensures ac power cannot be turned on unless all of the panels are closed and locked, their keys have been returned to a key transfer case and the ground has been removed from the antenna feed cable. See paragraph 2.6 for detailed information.

### 2.2.10 Remote Control Circuits

Refer to the NX200 Transmitter's *Installation Manual* for information on remote control circuits.

### 2.2.11 Remote Status Indications

Refer to the NX200 Transmitter's *Installation Manual* for information on remote status indications.



## 2.3 INSTALLATION TASKS

Upon delivery of the main-standby transmitter system, observe and complete the following procedures.

### NOTE

*Unless otherwise noted, the following procedures are non-technical, which are defined as being those procedures that do not require technical knowledge of transmitter related circuits or their operation to complete.*

#### 2.3.1 Accepting the Shipment

All shipments should be inspected for transit damage prior to acceptance. Packing/shipping lists should be perused to determine contents of each crate. Table 2-3 lists all the kits provided by Nautel for the NX200 Transmitter systems, and the corresponding installation paragraph for each kit.

### CAUTION

***Sufficient manpower or mechanical assistance should be on hand when removing the system component pieces from packing crates.***

Table 2-3: Nautel Supplied Kits for the NX200 Transmitter Systems

<b>System (Part #)</b>	<b>Soda Load Kit #</b> (see 2.3.7)	<b>Mains Equipment Kit #</b> (see 2.3.9)	<b>4-Port Switch Kit #</b> (see 2.3.10)	<b>Transmission Line Kit #</b> (see 2.3.11)	<b>Ventilation System Kit #</b> (see 2.3.12)	<b>Misc Kit #</b>
NX200 (Common) (201-1321-02)	228-8305-01	228-8309-01	228-8306-01	228-8307-01	228-8311-02	228-8313-01



### 2.3.2 Unpacking Instructions

The unpacking instructions are dictated by the method of packaging for shipment. System components that are not shipped by electronic equipment moving specialists may be packed in wooden crates, with the number of crates determined by the extent of disassembly for shipment. Instructions accompany any crate that requires special unpacking information.

Remove all items from packing and place on a suitable work area. Verify shipped contents with packing lists, which provide detailed listings of shipment contents.

#### NOTE

*The transmitter system will be partially disassembled for shipment. The extent of any additional disassembly will be dictated by the shipping method, site information provided by the user and the handling equipment of the mover.*

- (a) It is recommended the crates be positioned near the system's final assembly location prior to unpacking. See Appendix A for System Layout drawings for each site.
- (b) For each crate, remove the panel labelled 'open this side', noting it is attached by cross recessed (Philips) head screws.
- (c) Remove any visible packing material, including braces, from the crate's interior.
- (d) Remove the 14 inch lag bolts (requires 7/16 inch socket) securing the remaining panels to the base of the crate and carefully lift away the crate side/top panels.
- (e) Carefully lift/slide the crate contents off the base of the crate and place them in their assigned positions.

### 2.3.3 Visual Inspection

Perform a visual inspection on the transmitter system. The inspection should cover the following:

- (a) Remove any packing materials (tape, tyrap) used to secure wiring that was disconnected for shipment.
- (b) Check for obvious damage and missing parts.
- (c) Check electrical wiring/cabling for broken or frayed insulation, loose or improper connections, and broken, shorted or pinched conductors.
- (d) Verify all hardware is firmly tightened.
- (e) Remove any unwanted foreign objects from the interior of the cabinet/assemblies, paying particular attention for floating conductive materials such as wire strands, metal slivers/filing, and loose hardware.



#### 2.3.4 Cabinet Pre-Positioning

Refer to the appropriate system drawing (see Appendix A) for positioning and dimensional information. Position the main-standby transmitter system in its final location as follows:

##### NOTE

*The final orientation and positioning of the transmitter system components has been pre-determined, based on the dimensional information provided with the pre-installation package. See Appendix A for a series of System Layout drawings that will aid in installation.*

*Some system components (4-port switch and IMU) and interconnecting ac wiring (cable trays), transmission line and ventilation ducting are intended to install above the main transmitter components, and require user-provided support structures. Ensure these support structures are in place before proceeding.*

- (a) Place the main-standby system components in their final location, ensuring that their location will accommodate the installation of ac cable trays, transmission line and ventilation system.

##### NOTE

*In the following text, reference is made to transmitter A and transmitter B. Transmitter A is the NX200 transmitter and transmitter B is the existing on-site transmitter.*

- (b) Position transmitter A, noting the NX200 is partially disassembled for shipping. Refer to the *NX200 Transmitter Installation Manual* for instructions to re-assemble the NX200 Transmitter.

#### 2.3.5 Not Used

#### 2.3.6 Assembling the Main-Standby Transmitter System

The following procedure describes how to assemble the main-standby system.

- (a) Reassemble the NX200 Transmitter as described in the *NX200 Transmitter Installation Manual*.
- (b) Install the NX200 transmitter's antenna ground switch as detailed in the *NX200 Transmitter Installation Manual*.
- (c) Perform the installation for the remaining system components by referring to their installation procedures referenced below:
  - Test Load and Dry Cooler - see paragraph 2.3.7
  - Antenna Tuning Unit - see paragraph 2.3.8
  - Ac Power System- see paragraph 2.3.9
  - 4-Port Switch and Impedance Matching Unit - see paragraph 2.3.10
  - Transmission Line - see paragraph 2.3.11
  - Ventilation - see paragraph 2.3.12
  - Miscellaneous - see paragraph 2.3.13





This page intentionally left blank



### 2.3.7 Test Load and Dry Cooler - Installation Tasks

#### Appendix References:

- Appendix A
- Appendix B (various)

#### NOTE

*It is highly recommended you position **ALL** of the transmitter system's components in their final locations prior to installing cable trays, interconnecting wiring, plumbing, transmission line and ventilation.*

See Tables 2-4 and 2-5 for specifications and kits associated with the soda loads and dry coolers used in each NX200 Transmitter system.

Table 2-4: Specifications and Kits for the Soda Load and Dry Cooler for the NX System

System	Soda Load Kit #	Soda Load (120-ohm, 400 V, 3-Ph, 50 Hz)				Dry Cooler		
		Nautel Part #	Power (kW)	Weight kg (lbs)	Wiring Kit #	Nautel Part #	Weight kg (lbs)	Wiring Kit #
NX200	228-8305-01 (Common)	UP134	400	907 (2000)	228-8321	UP138	1124 (2473)	228-8320

- (a) Using necessary mechanical assistance (forklift, etc.), position the dry cooler in its final location on the pre-built concrete foundation (see Figure 2-1). See Appendix B for manufacturer's installation instructions for the soda load and dry cooler. For dry cooler installation, Nautel recommends the following (see Figure 2-8):
- Do not unpack the dry cooler from its shipping crate. Using a forklift to lift on the wood frame may be easier than using a crane on the dry cooler's lifting hooks.
  - Use a forklift with 10-ft long fork extensions and rated for 5000 lbs (2267 kg).
  - Lift the dry cooler, within its shipping crate, from its side (see Figure 2-8). Set the forks as much as possible to stabilize the dry cooler when lifting.
  - Once the dry cooler is safely on its intended foundation, remove all of the upper shipping crate frame, then use the forklift to slightly lift the dry cooler one end at a time to remove the skids under the dry cooler legs.
- (b) Perform a pressure check on the dry cooler to verify there has been no shipping damage.
- (c) Using necessary mechanical assistance (forklift, etc.), position the soda load in its final location (see the appropriate Figure 1a through 1d). Nautel recommends a forklift, with 8-ft long fork extensions, that is rated for 5000 lbs (2267 kg).



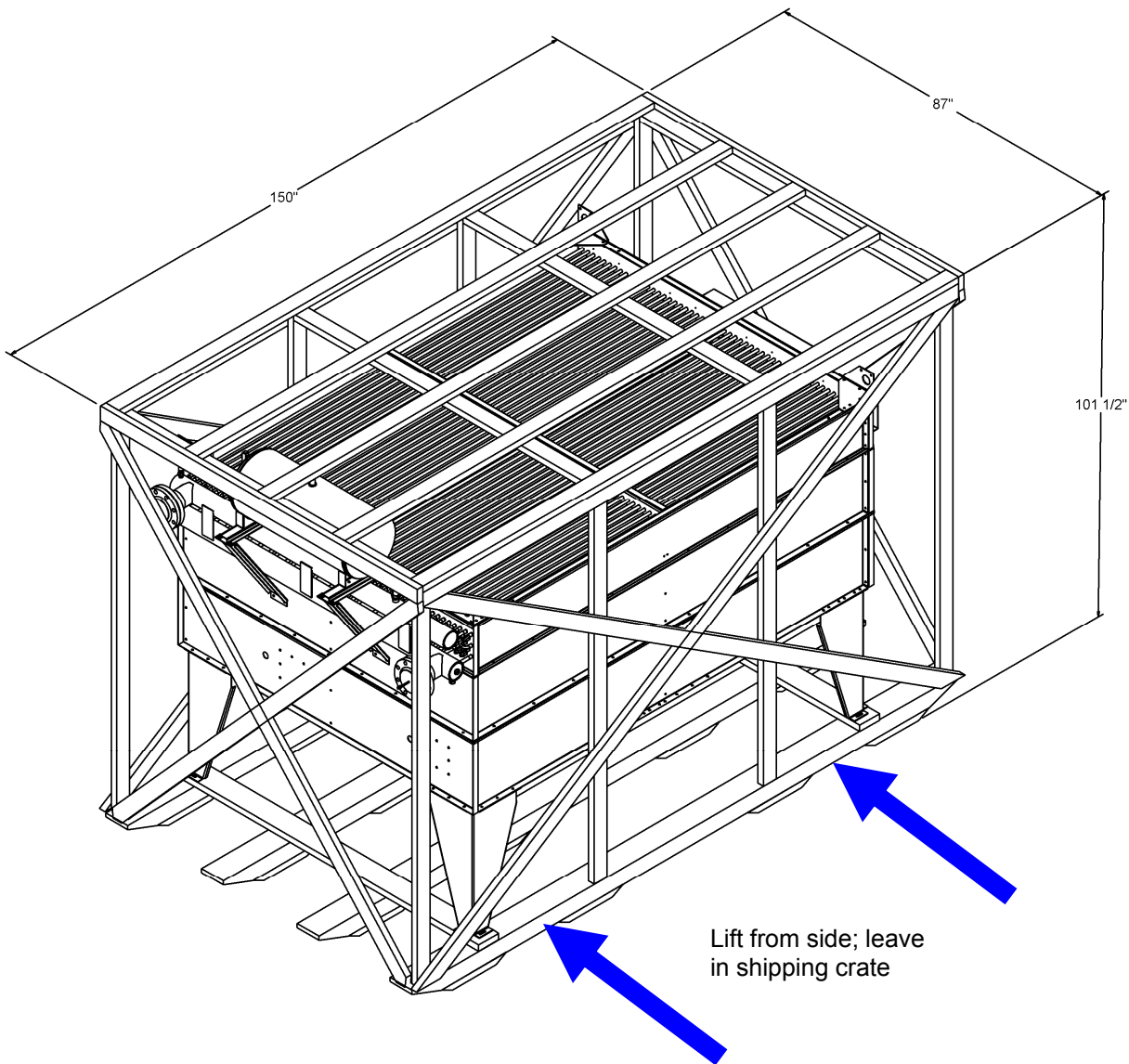

Figure 2-8: Lifting the Dry Cooler (shown in shipping crate)

- (d) Attach the resistor assembly on the main unit (see Appendix), noting it is secured to a round flange on the soda load using eight large bolts.
- (e) Unpack the plumbing kit (see Table 2-5 to determine the kit number) and assemble/install between load and dry cooler (see Figure 2-9). This should be performed by a licensed plumber. Refer to the Plumbing Installation Tasks (section 2.4) of the Soda Load manual in Appendix B.



Table 2-5: Plumbing Kits for Soda Load and Dry Cooler for each NX System

System	Plumbing Kit #
NX200	228-8360-03 (2-1/2 inch) (Common)

- (f) Where plumbing is exposed to the sun, paint the plumbing white.
- (g) Locate and unpack the soda load's wiring kit (see Table 2-4). The kit contains a 3-pole disconnect switch, lengths of Teck 90 cable and the necessary connectors and lock nuts for the Teck 90 cable to install the ac wiring for the load.
- (h) Locate and unpack the dry cooler's wiring kit (see Table 2-4). The kit contains a 3-pole disconnect switch, a length of Teck 90 cable and the necessary connectors and lock nuts for the Teck 90 cable to install the ac wiring for the dry cooler.

WARNING

***Ensure the ac power source for the soda load and dry cooler are disabled or locked out before proceeding. If this is not observed, voltages that are fatal - may be present.***

- (i) Arrange for a licensed electrician to install the following (see Figure 2-10 for a schematic):
  - ac disconnect switch for each of the soda load and dry cooler (should be in close proximity the each of the soda load and dry cooler).
  - Teck 90 cable between the 400 V, 3-phase ac power source(s) and the ac disconnect switches.
  - Teck 90 cable between the soda load's ac disconnect switch and the soda load and between the dry cooler's ac disconnect switch and the dry cooler.

NOTE

*For more information on installing Teck 90 cable and connectors, refer to the Teck Series Cable Fittings information in Appendix D.*

- (j) Using the Install the control wiring between the soda load and the dry cooler. See Figure 2-10 and the Soda Load Manual (see Appendix B) for more information.
- (k) Install interlock wiring between the soda load and the 4-port switch's control box (mounted near the 4-port switch). See Figure 2-10 and the Soda Load Manual (see Appendix B) for more information.



(l) Complete the instructions in Section 2 (Dry Cooler Installation) and Section 3 (Soda Load installation) of the Soda Load Manual (see Appendix B), which includes:

- plumbing notes
- checking dry cooler motor rotation
- checking dry cooler air flow
- verifying soda load pump rotation
- initial ac turn-on
- charging/testing the load for leaks (potable water, not provided)
- adding sodium carbonate to the load
- low power testing the load
- adjusting and calibrating
- medium power testing
- high power testing
- charging the water coolant and leak test [mix of glycol (provided) and potable water (not provided)]
- draining information

(m) Set up the load for operation and verify the impedance using the NX200 Transmitter's AUI (see the NX200 Transmitter's Operations and Maintenance Manual for further details). Set up the NX200 Transmitter to operate at 10% of its maximum capability (i.e., 20 kW for NX200).



Installation Requirements:

**NOTE:** Installation should be performed by a licensed plumber.

1. Unpack plumbing kit and verify - using the packing list - that all parts are present.
2. 2-1/2 inch pipe is provided in 10-ft (3 m) lengths. Cut pipes to the lengths shown in Figure 2 and thread as required.
3. Install all pieces as shown.
4. Any plumbing exposed to the sun should be painted white.

Plumbing Kit 228-8360-03 Contents:

Qty	Part #	Description
5	HAC87	PIPE, BLK Iron, 2-1/2", STD Wall, 126" LG THDED Both Ends
10	HAC90	ELBOW, BLK IRON, 2-1/2", 90 DEG, 150 PSI
2	HAC94	FLANGE, STEEL, 2.5", THREADED, 150 PSI
0	-	Not Used
2	HAC89	Nipple, 4 IN, BLK Iron, Fully Threaded, 150 PSI
2	HAC101	FLANGE, STEEL, 4", THREADED, 150 PSI
2	HAC96	COUPLING, Reduce, 4 IN TO 2 1/2" BLK Iron, 150 PSI
2	HAC98	GASKET, RING FLANGE, 2 1/2 IN WITH FASTENERS
2	HAC102	GASKET, RING FLANGE, 4 IN WITH FASTENERS
1	HAC100	Sealant, Pipe Thread, 8 OZ Brush Top Can
2	HAC103	Nipple, 2 1/2 IN, BLK Iron, Fully Threaded, 150 PSI
2	HAC106	Tee, Reduce, Inline, 2-1/2" To 1-1/2", Blk Iron, 150 PSI
2	HAC108	Valve, Ball Lever, 1-1/2" NPT Male/Female, BRASS, 600 PSI

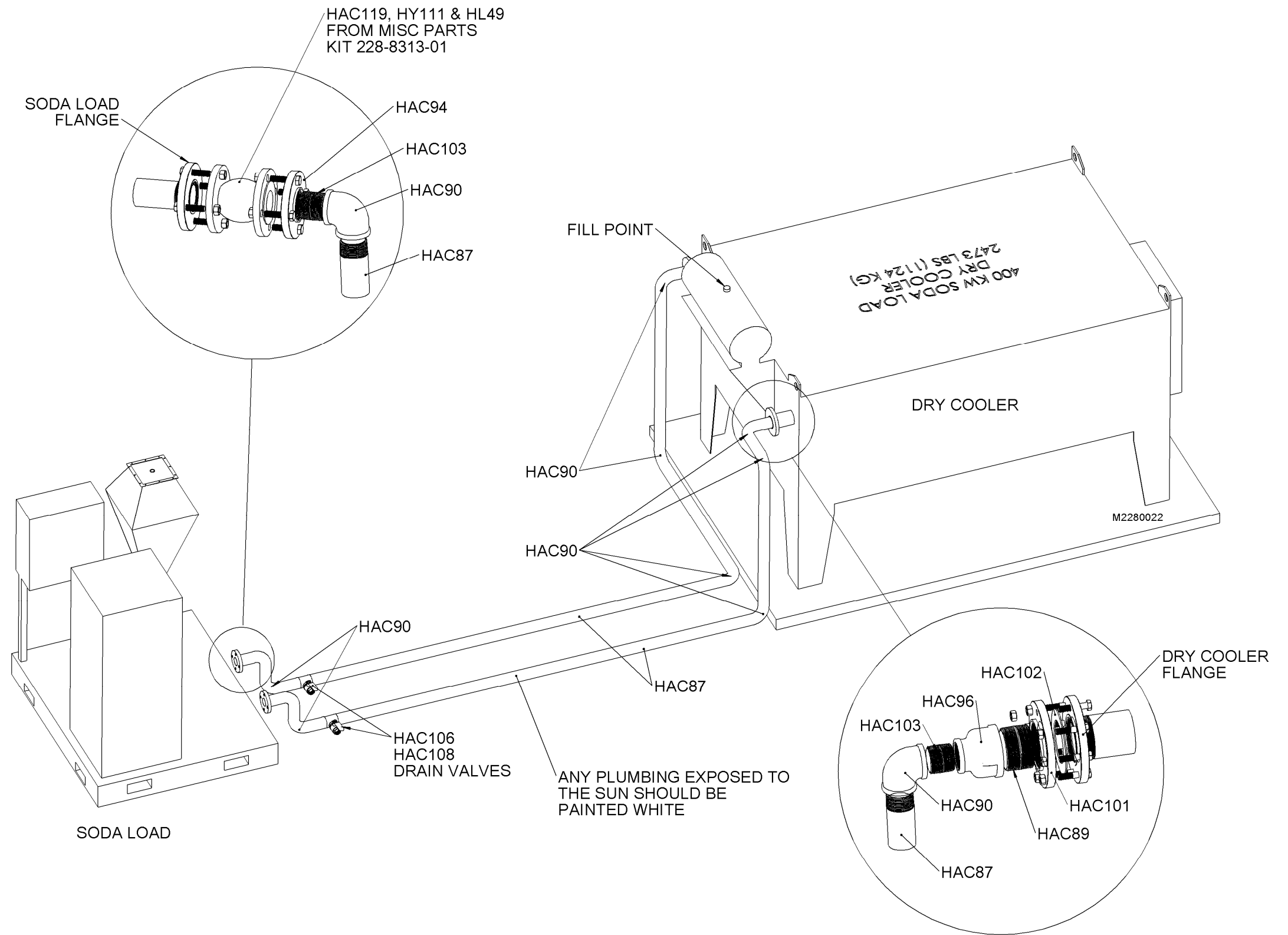

VIEW A - SODA LOAD CONTROL BOX - CABLE HOLE LAYOUT

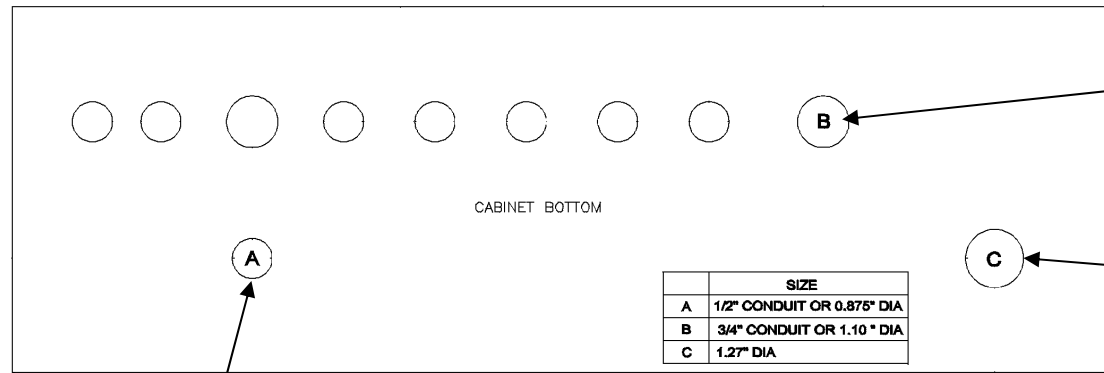

Install HAA93

Route WG58 control wiring and connect as shown below

VIEW B - SODA LOAD CONTROL BOX - AC AND CONTROL CONNECTIONS

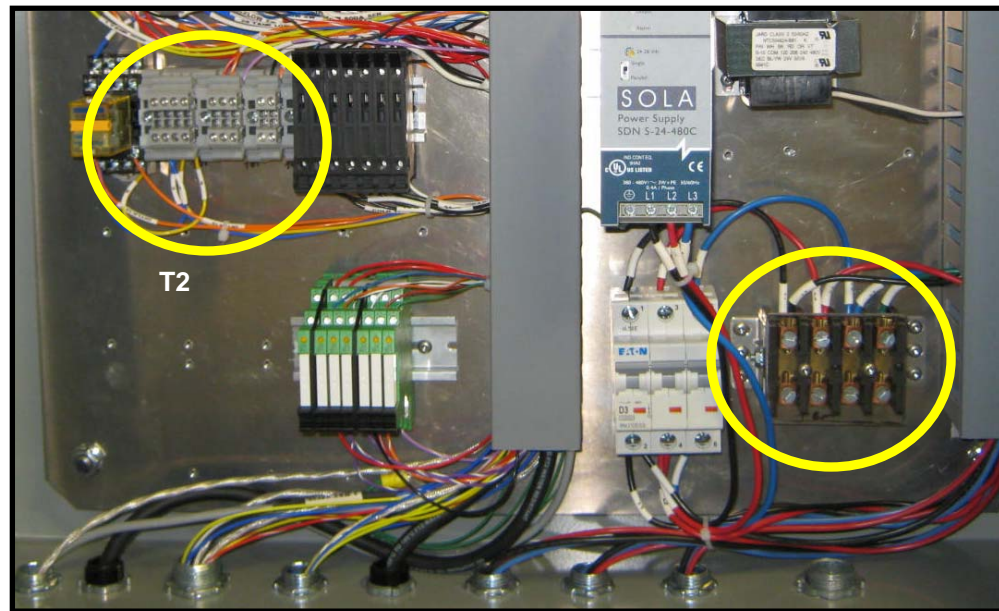

VIEW C - CONTROL/INTERLOCK

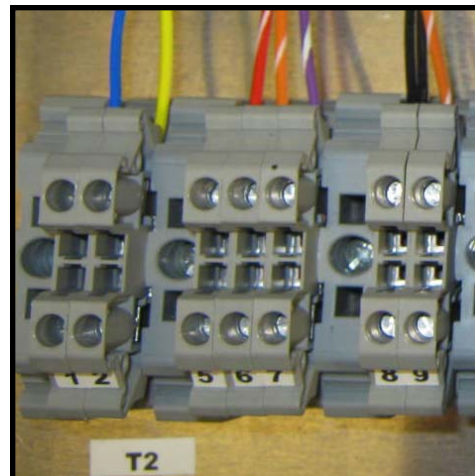

VIEW D - 400 V AC, 3-PH INPUT

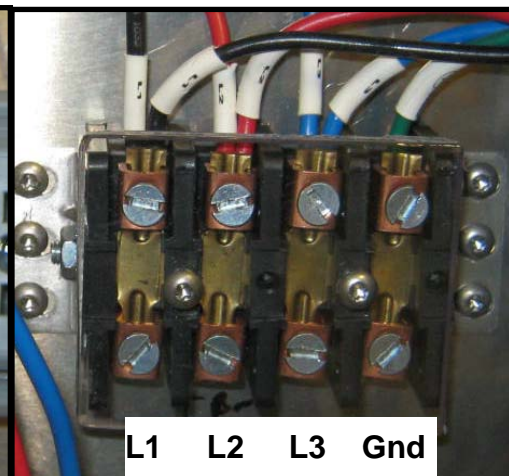

CONTROL/INTERLOCK WIRING CONNECTIONS

FROM	TO	WIRE	REMARKS
SL-T2-3	4-port switch control box	WE32	Interlock
SL-T2-4	4-port switch control box	WE32	Interlock
SL-T2-5	DC-005	WG58	M1/M2 enable
SL-T2-6	DC-008	WG58	M3/M4 enable
SL-T2-7	DC-011	WG58	M5/M6 enable
SL-T2-8	DC-003 (ac com)	WG58	Ac Common
SL-T2-9	DC-002 (24 ac)	WG58	24 V ac

SL = Soda Load; DC = Dry Cooler

VIEW E - DRY COOLER ELECTRICAL ENCLOSURE LAYOUT

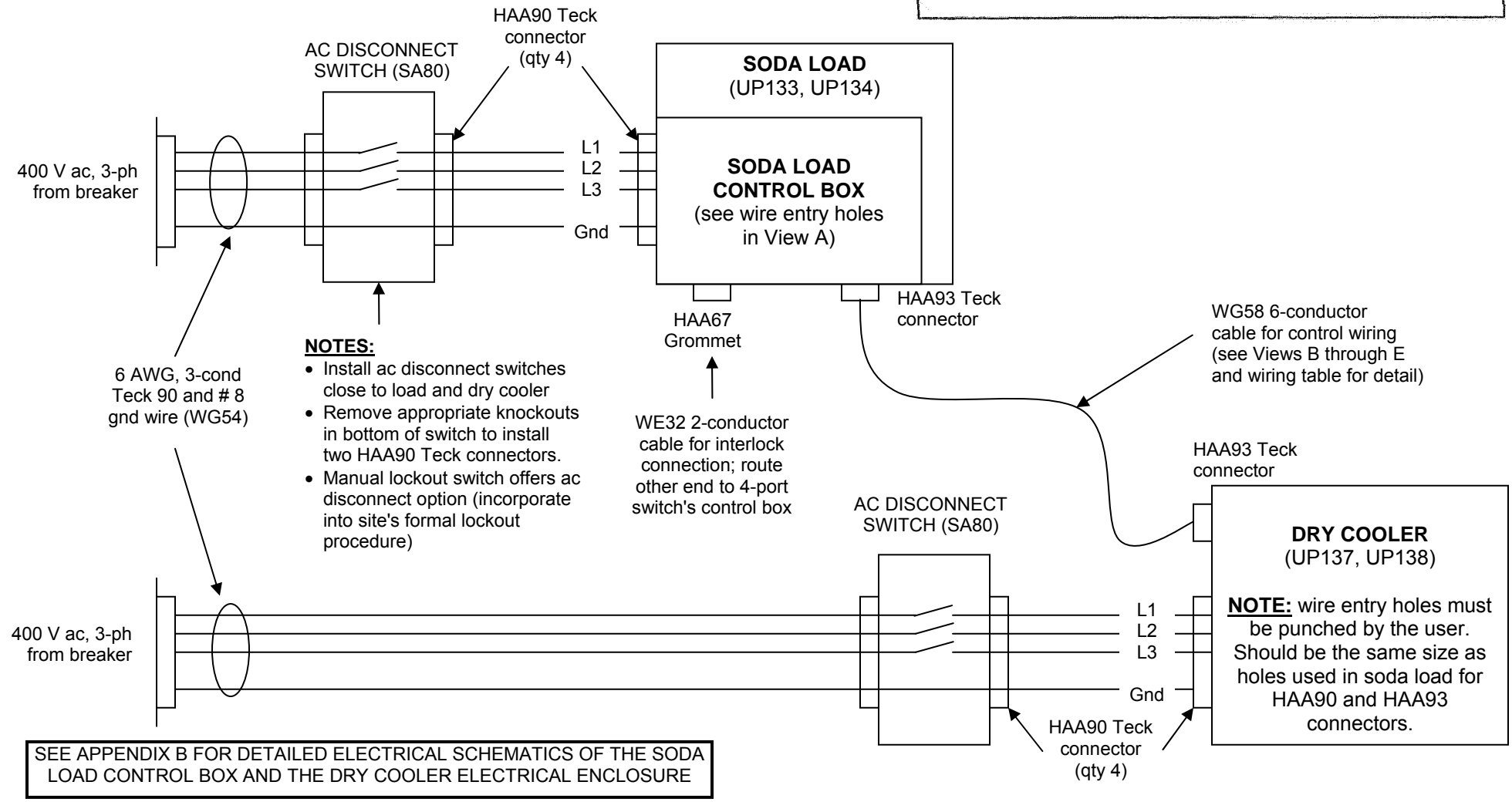
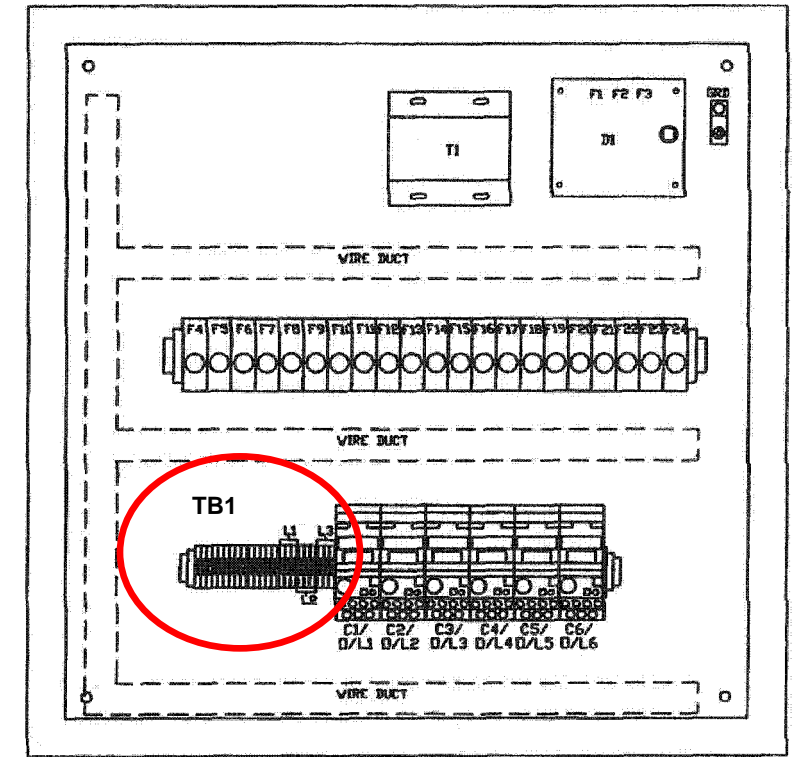

### 2.3.8 ATU - Installation Tasks

#### Appendix References:

- Appendix C

#### NOTE

*It is highly recommended you position **ALL** of the transmitter system's components in their final locations prior to installing cable trays, interconnecting wiring, plumbing, transmission line and ventilation.*

#### NOTE

*The following installation procedures should be performed by qualified technical personnel.*

- (a) Unpack the appropriate ATU and confirm that all parts have been included. Table 2-6 shows the ATU part number for each specific site.

Table 2-6: ATU System Part Numbers

ATU Part #	System	ATU Part #	System
UE154	Jammu - NX300	UE168	Itanagar - NX200
UE155	Jalandhar - NX300	UE169	Jabalpur - NX200
UE156	Lucknow - NX300	UE170	Vijayawada – NX100
UE157	Dibrugarh - NX300	UE171	Tiruchirappalli - NX100
UE158	Rajkot - NX300	UE172	Patna - NX100
UE159	Suratgarh - NX300	UE173	Ranchi - NX100
UE160	Delhi (A) - NX200	UE174	Mumbai (A) - NX100
UE161	Chennai – NX200	UE175	Mumbai (B) - NX100
UE162	Bangalore - NX200	UE176	Panaji - NX100
UE163	Dharward - NX200	UE177	Pune - NX100
UE164	Kolkata (A) - NX200	UE178	Varanasi - NX100
UE165	Ajmer - NX200	UE179	Passighat –NX100
UE166	Siliguri - NX200	UE180	Kolkata (B) – NX100
UE167	Ahmedabad - NX200		

- (b) Build the ATU weather shelter. See Kintronics example assembly drawings/instructions in Appendix C.
- (c) Assemble/install ATU. See Kintronics example assembly drawings/instructions and photos as well as additional technical details in Appendix C.
- (d) Install two grounding switches (see Figure 2-11) - one on the 120-ohm side, one on the antenna feed side. See Kintronics assembly drawings/instructions in Appendix C.
- (e) Install/assemble the ATU safety cage (see Figure 2-12). See Kintronics assembly instructions in Appendix C.









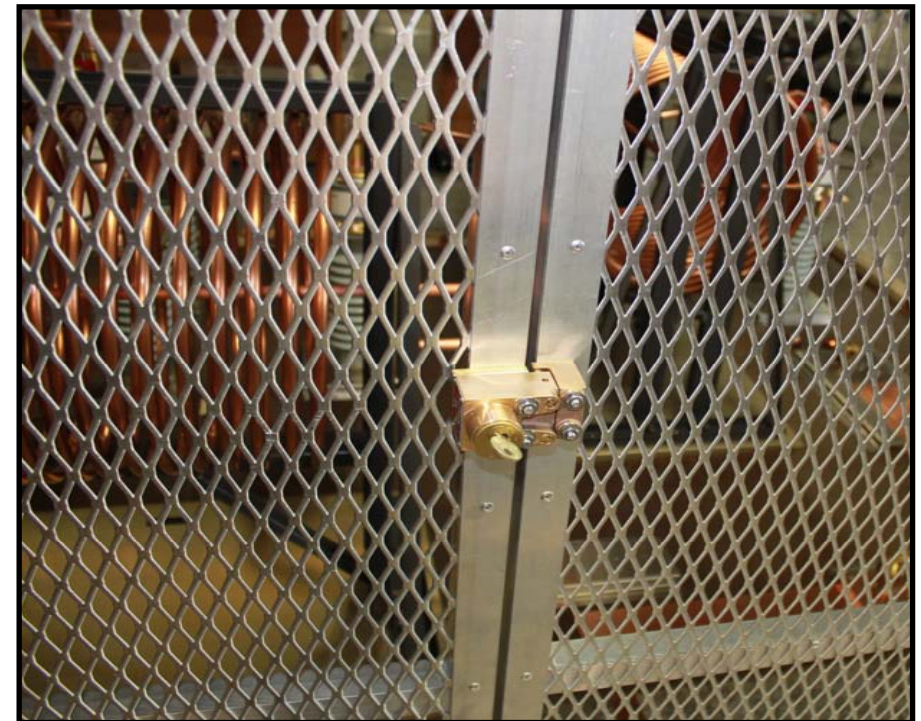

WARNING

**Ensure the main ac power source for the transmitter system is disabled or locked out before proceeding. If this is not observed, voltages that are fatal will be present.**

2.3.9 Ac Power Components - Installation Tasks

Appendix References:

- Appendix A
- Appendix D (various documents)

NOTE

*It is highly recommended you position **ALL** of the transmitter system's components in their final locations prior to installing cable trays, interconnecting wiring, plumbing, transmission line and ventilation.*

**IMPORTANT!** *You must have a licensed electrician to install all ac wiring and switches to ensure proper operation of equipment and safety to personnel. Failure to observe this requirement may result in voiding of the warranty.*

See Table 2-7 for specifications and kits associated with the ac mains equipment used in each NX200 Transmitter system.

Table 2-7: Specifications and Kits for the Ac Main Equipment for the NX200 System

System	Mains Equipment	Breaker Panel	Primary Wiring Kit #	Secondary Wiring Kit#	Surge Box Kit#	Ac Disconnect Switch	Emergency OFF Switch Wiring Kit #
NX200 (Common)	228-8309-01	800 A 317.5 kg (700 lbs) UE183A	228-8322-01	228-8323-02	228-8310	228-8422	228-8326



### WARNING

**Ensure the main ac power source for the transmitter system is disabled or locked out before proceeding. If this is not observed, voltages that are fatal will be present.**

- (a) Locate and unpack the mains equipment for a specific site, noting that Nautel has provided the Mains Equipment Kit that contains all components to complete the ac power system installation (NX200 Transmitter and its power transformer are provided separately). See Table 2-7 to confirm the correct kit and its contents for each site.

### NOTE

*It is highly recommended you position **ALL** of the transmitter system's components in their final locations prior to installing cable trays, interconnecting wiring, plumbing, transmission line and ventilation.*

- (b) Using necessary mechanical assistance (forklift, etc.; see Table 2-7 for weights of heavier equipment), position the mains equipment components in their final location (see Appendix D for installation assistance). The breaker panel is intended to be bolted to the transmitter room floor.
- (c) Verify the ac disconnect switch (see Table 2-7 for the appropriate part number for your site) is installed in its intended location on a wall near the breaker panel. See transmitter system layout drawings, if necessary.
- (d) Locate the Surge Box Kit (Nautel Part # 228-8310) from the Mains Equipment Kit. This kit contains the NAX188 Surge Protection Panel and the 228-8324 NAX188 Installation Kit, which in turn contains the Teck90 wire (3-conductor plus ground) and associated connecting hardware for wiring between the breaker panel and the NAX188 surge protection panel.
- (e) Verify the NAX188 surge protection panel is installed in its intended location on a wall near the breaker panel. See transmitter system layout drawings, if necessary.
- (f) Verify the NX200 Transmitter and its associated power transformer (noting primary and secondary orientation) are installed in their intended locations. See transmitter system layout drawings, if necessary.

#### **2.3.9.1 Not Used**



## WARNING

**Ensure the main ac power source for the transmitter system is disabled or locked out before proceeding. If this is not observed, voltages that are fatal will be present.**

### 2.3.9.2 Ac Breaker Panel

- (a) Verify the breaker panel is bolted to the floor. See Appendix D for manufacturer's information.

#### NOTE

*You should only require access to the interior of the breaker panel through the front and right-hand side panels. Ensure panels are re-installed when installation is complete.*

- (b) Remove the steel top plate from the top of the ac breaker panel. Locate the aluminum cover in the Misc Parts Kit (Nautel Part # 228-8313-01 for NX200 systems) and install it in its place using the existing mounting holes in the top of the breaker panel (see Figure 2-15). **NOTE:** the holes in the top plate are intended for specific wiring connections. See Figure 2-15 for labeling.
- (c) Install the three-phase wiring to the breaker panel's ac input. Refer to Figure 2-15 and Appendix D for detailed information on the breaker panel. Bring ac input wiring into the bottom of the cabinet. Group the ground strands of the Teck 90 cable and ground them at the breaker panel ground (see Figure 2-14).

#### NOTE

*Single conductor high-current armored cables such as Teck 90 cable require special termination methods to prevent excessive heating caused by induced circulating current in nearby conductors and eddy currents in nearby magnetic materials. Figure 2-14 shows one acceptable method.*

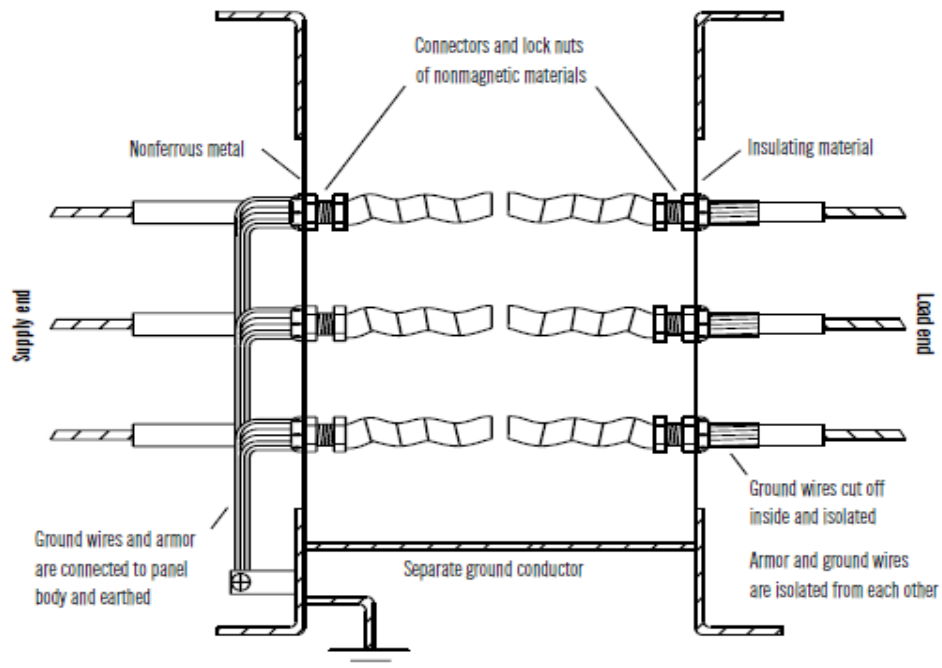
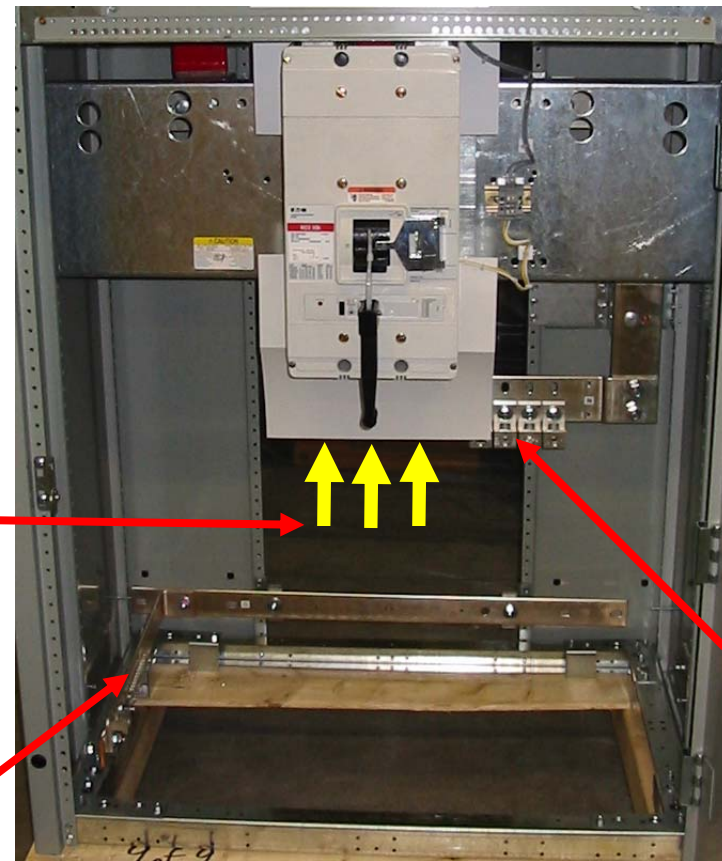

Figure 2-14: Terminating Teck 90 conductors





**3-PHASE AC MAINS INPUT**  
(front panel removed)



3-Phase, 400 V ac line inputs from ac mains

Neutral from 400 V ac mains input

Ground bus

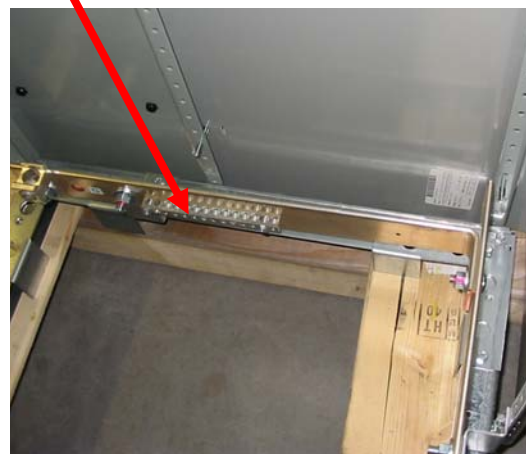

View of cabinet bottom

Six strands (two per phase)  
313 MCM DLO cable exit through top plate of cabinet



**3-PHASE, 800 A OUTPUT**

Terminations for HAM81 connectors to connect the primary wire (WT05) between the 800 A breaker output and the ac disconnect switch.

Access through the front and right-hand side panels.

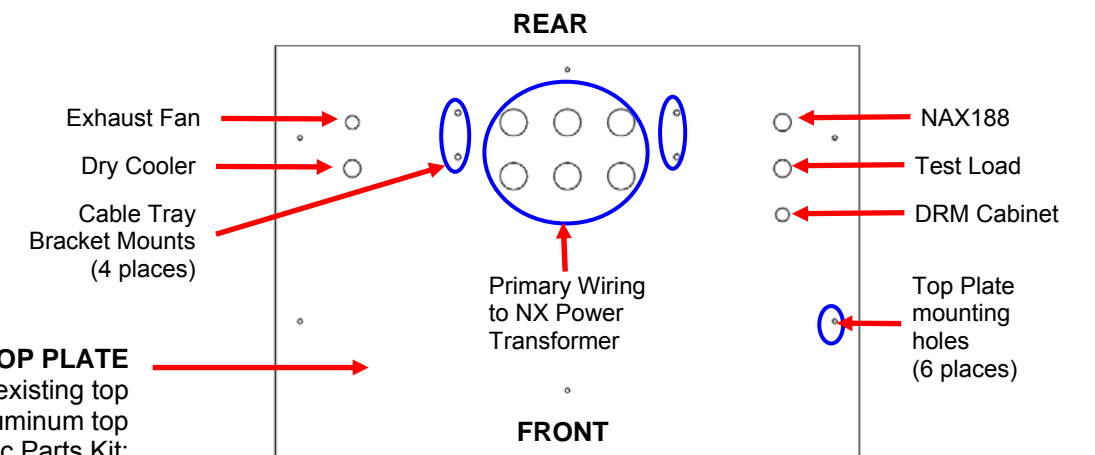

**TOP PLATE**  
Replace existing top cover with aluminum top plate from Misc Parts Kit:  
228-8313 (NX100)  
228-8313-01 (NX200)  
228-8313-02 (NX300)

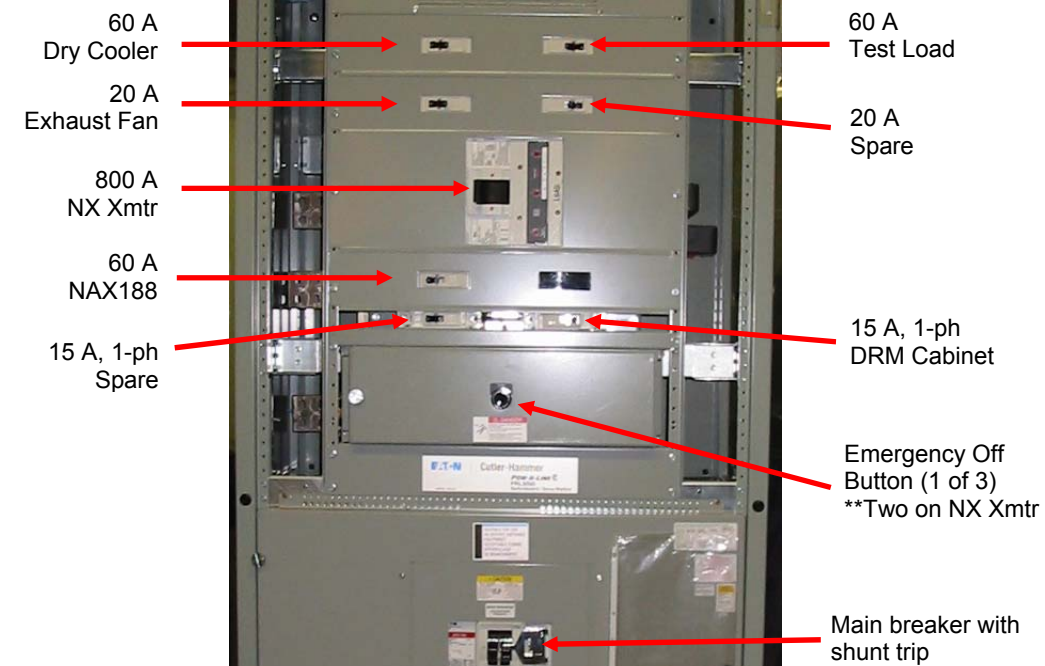

**BREAKER LOCATIONS**  
(right and left access covers removed)



Assembly Details - Breaker Panel (UE183A) for NX200 Systems			
Issue 0.3	Not to Scale	Figure 2-15	Page 2-41 (2-42 Blank)



### WARNING

**Ensure the main ac power source for the transmitter system is disabled or locked out before proceeding. If this is not observed, voltages that are fatal will be present.**

#### **2.3.9.3 Ac Wiring Cable Trays**

- (a) Assemble and install the primary and secondary cable tray systems, noting the required pieces are located in the Primary Wiring Kit and Secondary Wiring Kit from the Mains Equipment Kit (see Table 2-7 for the part number for your site). Refer the appropriate assembly drawing for your site (Figure 2-21) as an aid in assembling the cable trays. If necessary, contact Nautel for assistance.

**NOTE:** *Items in the Primary Wiring Kit are intended for use between the breaker panel, ac disconnect switch and NX power transformer's primary side. Items in the Secondary Wiring Kit are intended for use between the NX power transformer's secondary side and the NX200 Transmitter.*

- (b) During installation, support cable trays from the floor, noting the cable tray and wire weight specified in the assembly instructions drawing. Ensure that supports do not restrict access to system components (i.e., front panels, doors, etc.). The end user is responsible for providing all supports.

### CAUTION

**Nautel or associated third-party equipment is not designed to support cable trays or wiring, nor should it be used to stand on at any time.**

#### **2.3.9.4 Primary Ac Wiring**

- (a) Obtain the 313 MCM DLO wire (Nautel Part # WT05) and the 3/0 AWG diesel wire (Nautel Part # WT06) from the Primary Wiring Kit. This wire was chosen to satisfy the current requirement, cable tray rating and extreme flexibility requirement. The WT05 wire is used for each phase (three wires per phase for NX300 systems; two wires per phase for NX200 systems; one wire per phase for NX100 systems) and the WT06 is used for the ground. These wires route between the breaker panel and ac disconnect switch, and between the ac disconnect switch and the NX power transformer's primary.
- (b) Cut equal length pieces of WT05 (six for NX200 systems) and WT06 (one wire only) that are of sufficient length to comfortably route between the breaker panel's high-current output terminals and the ac disconnect switch's input copper plates, via the cable tray. Input wiring enters the ac disconnect switch at the bottom for NX200 systems. Where multiple wires are used per phase, as in NX200 systems, take care to make parallel phase wires the same length to improve current sharing.
- (c) With unterminated wires routed through the top of the breaker panel strain-relief connectors (there is a feed-through for each wire; grommet for the ground wire), strip 50 mm of insulation from each of the nine WT05 wires and the WT06 ground wire and install lug connectors (Nautel Part # HAM81 for WT05; Nautel Part # HAM82 for WT06) on this end of the wires (other end will be terminated later). Note that each lug connector has four bolts (M14 for HAM81; M12 for HAM82) that must be tightened to secure the wire in the lug.



- (d) Mark each phase wire (at both ends) with colored tape provided [blue, red, black (no tape)]. This is imperative to avoid short circuits when you initially energize the system. A serious arc flash can occur if a phase-to-phase short exists. Use green tape to identify the ground (WT06) wire.
- (e) Connect the WT05 wires and the WT06 wire to the breaker panel side. Secure the three wires for each phase and the ground wire to the terminals provided [torque to 50 in-lbs (5.6 N-m) for HAM81 lugs]. Repeat this for each of the three phases, totaling nine WT05 wire connections to the breaker panel. Ensure colored phase wires are grouped together.
- (f) Route wires along the cable tray to the ac disconnect switch, ensuring that the three phases (A, B and C) are bundled together in triangular patterns and cable cleats (Nautel Part # HO59) are used to properly secure wires to the cable tray (see Figures 2-16 and 2-17 for examples of proper techniques). Cable cleats are provided in the primary and secondary wiring kits to secure the larger ac wiring to the cable tray ladders. Secure cable cleat brackets (HX69) to the cable tray rungs using hardware provided with the cable cleat. Install cable cleats 3 ft. apart on straight ladder sections and 1 ft. apart on curved sections. See Figure 2-16 and Appendix D for detailed instructions to assemble and install cable cleats on cable trays.
- (g) Route all wires through the top of the ac disconnect switch, noting each phase wire passes through a feed-through strain-relief in the ac disconnect switch (see Figure 2-18). Open the front door of the ac disconnect switch. Ensure there is enough wire to connect to the copper plates (WT05) and angle bracket (ground for WT06) inside the switch box.
- (h) With wires placed near their approximate destinations, strip 50 mm of insulation from each of the WT05 wires (six for NX200 systems) and the WT06 ground wire and install lug connectors (Nautel Part # HAM81 for WT05; Nautel Part # HAM82 for WT06) on the ends of the wires. Note that each lug connector has four bolts (M14 for HAM81; M12 for HAM82) that must be tightened to secure the wire in the lug.
- (i) Ensure each phase is marked with colored tape (ground wire with green tape). Connect the end of the WT05 wires to the copper plates provided for each phase (see Figure 2-18). Secure the wire(s) for each phase (two for NX200 systems) to these copper plates [torque to 50 in-lbs (5.6 N-m) for HAM81 lugs]. Repeat this for each of the three phases. Ensure colored phase wires are grouped together. Connect the end of the WT06 ground wire to the angle bracket where a pre-existing internal ground wire is already installed.
- (j) Cut equal length pieces of WT05 (six for NX200 systems) and WT06 (one wire only) that are of sufficient length to comfortably route between the ac disconnect switch's output copper plates and the primary of the NX power transformer, via the cable tray (see Figure 2-21). Output wiring exits the ac disconnect switch at the top for NX200 systems. Where multiple wires are used per phase, as in NX200 a systems, take care to make parallel phase wires the same length to improve current sharing.



**WARNING**

**Ensure the main ac power source for the transmitter system is disabled or locked out before proceeding. If this is not observed, voltages that are fatal will be present.**

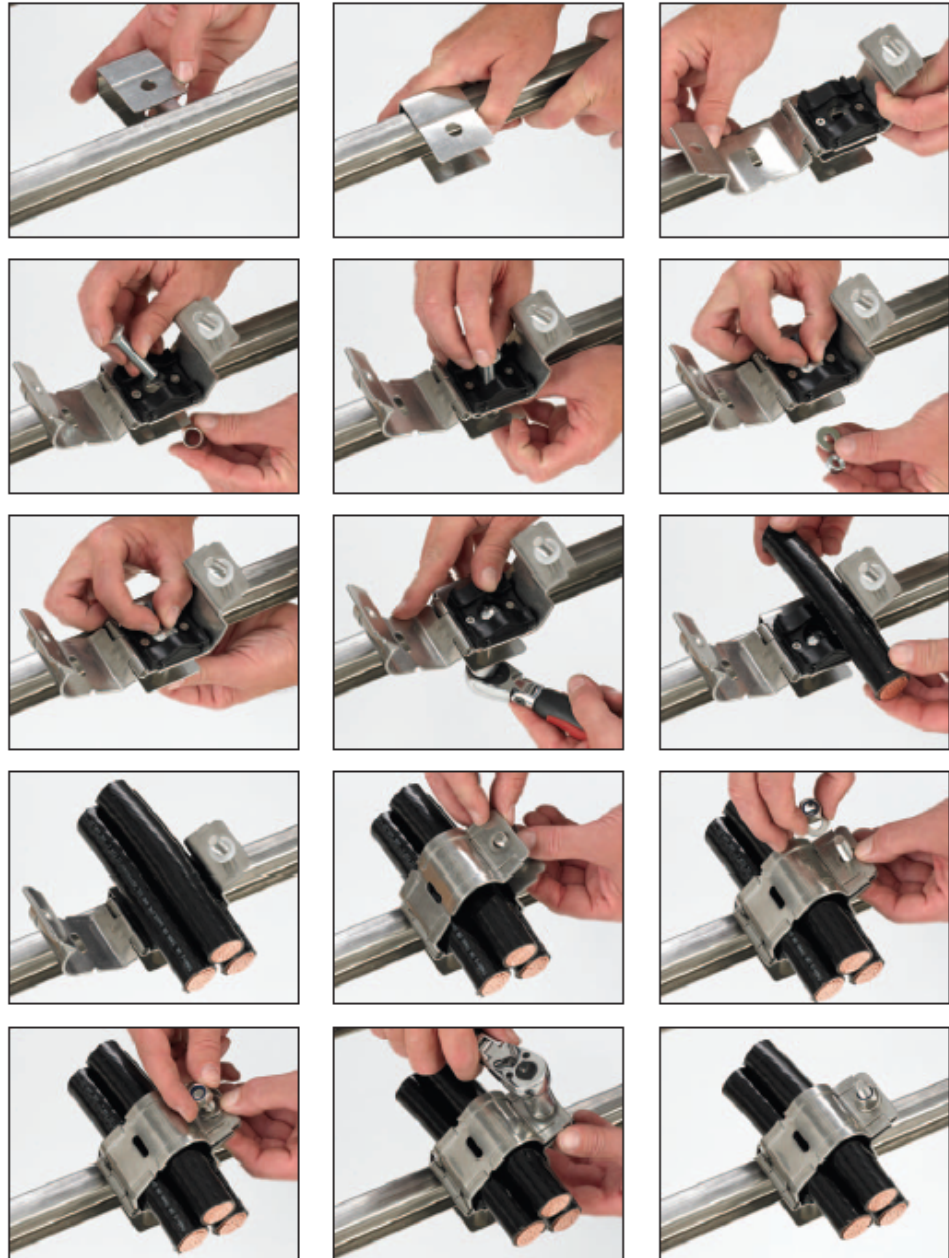

Figure 2-16: Step-by-step instruction to install cable cleats



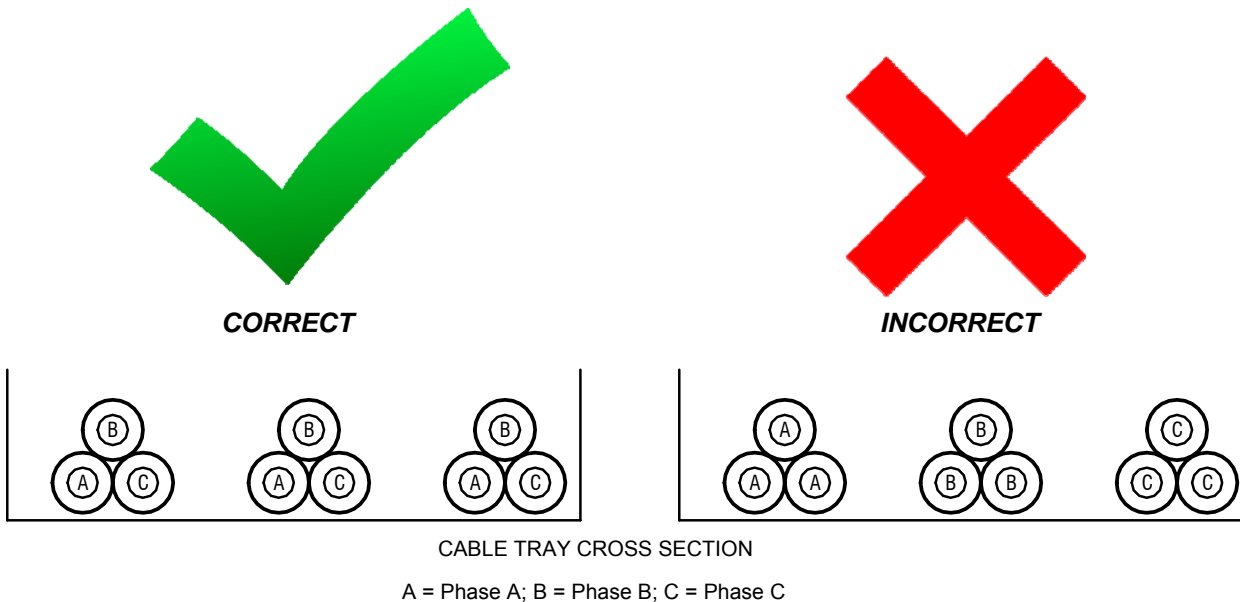

Figure 2-17: Arranging three-phase wires in cable cleats (NX300 system example shown)

- (k) With unterminated wires routed through the strain-relief connectors in the top (for NX200 systems) of the ac disconnect switch (there is a strain-relief for each wire; grommet for the ground wire), strip 50 mm of insulation from each of the WT05 wires and the WT06 ground wire and install lug connectors (Nautel Part # HAM81 for WT05; Nautel Part # HAM82 for WT06) on this end of the wires (other end will be terminated later). Note that each lug connector has four bolts (M14 for HAM81; M12 for HAM82) that must be tightened to secure the wire in the lug.
- (l) Mark each phase wire (at both ends) with colored tape provided [blue, red, black (no tape)]. Use green tape to identify the ground (WT06) wire.
- (m) Connect the end of the WT05 wires to the copper plates provided for each phase (see Figure 2-18). Secure the wire(s) for each phase (two for NX200 systems) to these copper plates [torque to 50 in-lbs (5.6 N-m) for HAM81 lugs]. Repeat this for each of the three phases. Ensure colored phase wires are grouped together. Connect the end of the WT06 ground wire to the angle bracket where a pre-existing internal ground wire is already installed.
- (n) Route wires along the cable tray to the NX power transformer, ensuring that the three phases (A, B and C) are bundled together in triangular patterns and cable cleats (Nautel Part # HO59) are used to properly secure wires to the cable tray (see Figures 2-16 and 2-17 for examples of proper techniques). Cable cleats are provided in the primary and secondary wiring kits to secure the larger ac wiring to the cable tray ladders. Secure cable cleat brackets (HX69) to the cable tray rungs using hardware provided with the cable cleat. Install cable cleats 3 ft. apart on straight ladder sections and 1 ft. apart on curved sections. See Figure 2-16 and Appendix D for detailed instructions to assemble and install cable cleats on cable trays.



**WARNING**

**Ensure the main ac power source for the transmitter system is disabled or locked out before proceeding. If this is not observed, voltages that are fatal will be present.**

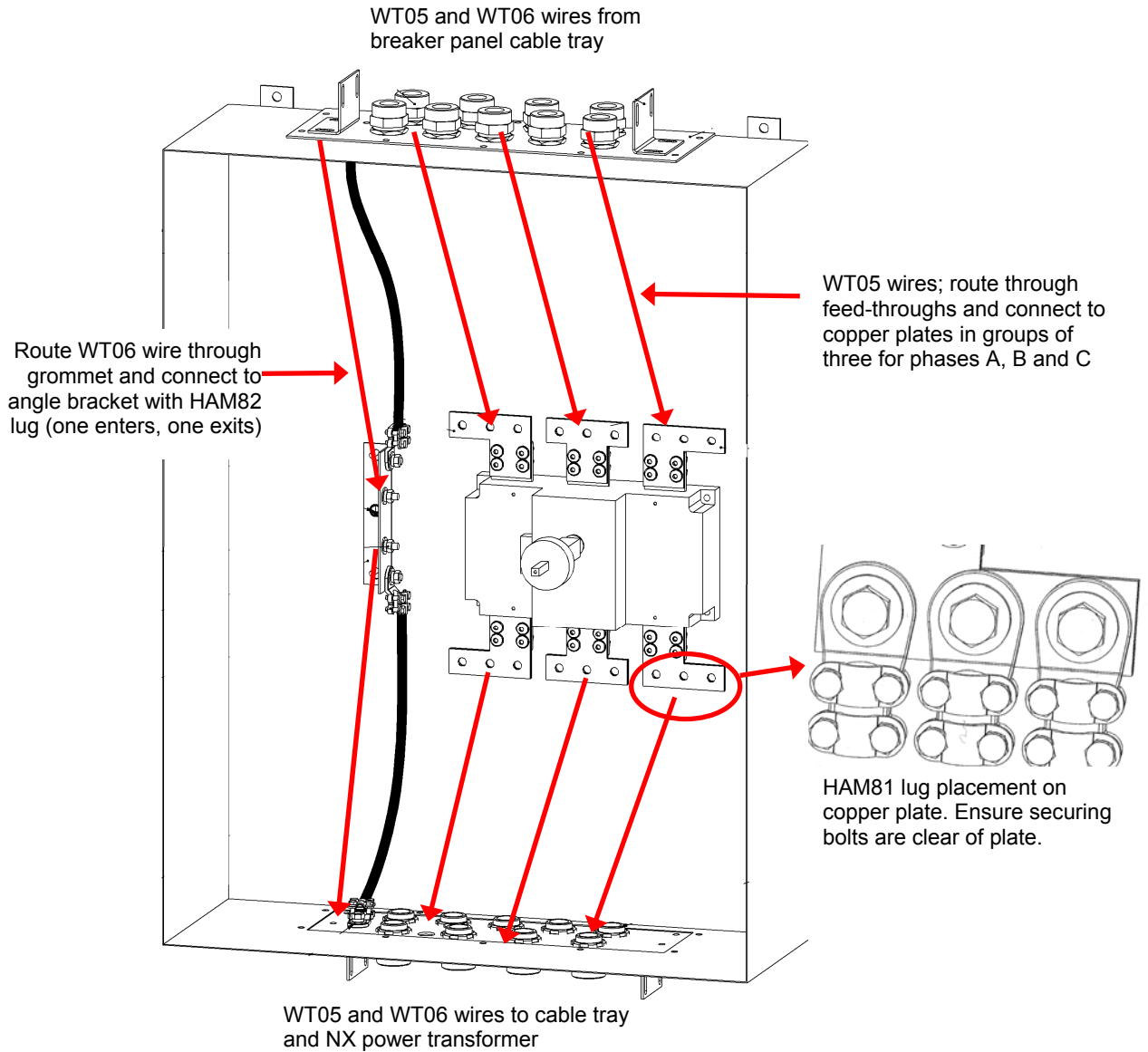

**NOTE:** For NX200 systems, wires enter through the bottom and exit through the top

Figure 2-18: Ac Disconnect Switch wiring connection (NX300 switch shown), door removed for clarity



- (o) Route all wires through the top of the NX power transformer's primary side, noting each phase wire passes through a feed-through strain-relief in the top of the transformer's primary side cable tray interface box (see Figure 2-21). Remove the access panel to the power transformer to view the primary terminals. Ensure there is enough wire to connect to the copper plates (WT05) and ground terminal (WT06) inside the transformer cabinet (see Figure 2-18).

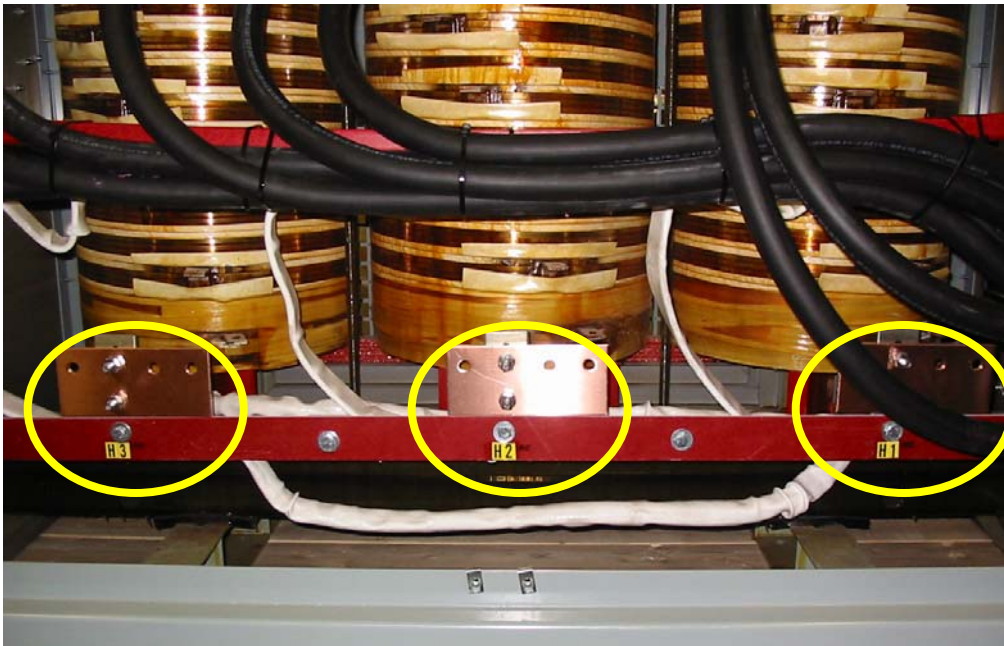

Figure 2-19: NX Power Transformer Primary Terminals (H1, H2 and H3), access panel removed for clarity

- (p) With wires placed near their approximate destinations, strip 50 mm of insulation from each of the WT05 wires and the WT06 ground wire and install lug connectors (Nautel Part # HAM81 for WT05; Nautel Part # HAM82 for WT06) on the ends of the wires. Note that each lug connector has four bolts (M14 for HAM81; M12 for HAM82) that must be tightened to secure the wire in the lug.
- (q) Ensure each phase is marked with colored tape (ground wire with green tape). Connect the end of the WT05 wires to the copper plates provided for each phase (see Figure 2-19). Secure the wire(s) for each phase (two for NX200 systems) to these copper plates [torque to 50 in-lbs (5.6 N-m) for HAM81 lugs]. Repeat this for each of the three phases (A, B and C). Ensure colored phase wires are grouped together. Connect the end of the WT06 ground wire to the transformer ground stud.
- (r) Tighten all strain-relief lock nuts on top of the breaker panel, top and bottom of the ac disconnect switch and the primary side of the NX power transformer.



### WARNING

**Ensure the main ac power source for the transmitter system is disabled or locked out before proceeding. If this is not observed, voltages that are fatal will be present.**

#### **2.3.9.5 Secondary Ac Wiring**

- (a) Obtain the 535 MCM DLO wire for three-phase connections (Nautel Part # WT04), the black neutral wire (Nautel Part # WT02) and the 1/0 AWG green ground wire (Nautel Part # WT01) from the Secondary Wiring Kit. This wire was chosen to satisfy the current requirement, cable tray rating and extreme flexibility requirement. These wires route between the NX power transformer's secondary and the NX200 Transmitter.

### NOTE

*NX200 transmitters require two sets of three-phase/neutral wiring. Refer to the NX200 Transmitter's Installation Manual for connection details for the secondary wiring.*

- (b) Cut lengths of WT04 (six for NX200 systems), WT02 (two for NX200 systems) and WT01 (one wire only) that are of sufficient length to comfortably route between the NX power transformer's secondary and the power compartment of the NX200 Transmitter cabinet(s), via the cable tray.
- (c) On the NX power transformer secondary (fuse) side, install Cytolok connectors on the wire and connect the wires as detailed in the NX200 Transmitter's Installation Manual. See Figure 2-20 for secondary connections locations. Ensure the "OO" side of the Cytolok connector is visible for WT04 (535 MCM) wire.



Figure 2-20: NX Power Transformer Secondary Connections (NX300 transformer shown)



- (d) Route secondary wires along the cable tray to the NX200 Transmitter, ensuring that the phase wires groups (three wires each) are bundled together in triangular patterns and cable cleats (Nautel Part # HO59) are used to properly secure wires to the cable tray (see Figures 2-16 and 2-17 for examples of proper techniques). Cable cleats are provided in the primary and secondary wiring kits to secure the larger ac wiring to the cable tray ladders. Secure cable cleat brackets (HX69) to the cable tray rungs using hardware provided with the cable cleat. Install cable cleats 3 ft. apart on straight ladder sections and 1 ft. apart on curved sections. See Figure 2-16 and Appendix D for detailed instructions to assemble and install cable cleats on cable trays.
- (e) Route all wires, except the green ground wire (WT01), into the cable channel at the top of the NX200 Transmitter's cabinet(s), noting each cabinet should receive three phase wires (WT04) and one neutral (Xo) wire (WT02). Refer to the NX200 Transmitter's Installation Manual to complete the installation of the three-phase neutral (Xo) and ground wiring. When installing Cytolok connectors on WT04 (535 MCM) wires, ensure the "OO" side of the Cytolok connector is visible.





## WARNING

***Ensure the main ac power source for the transmitter system is disabled or locked out before proceeding. If this is not observed, voltages that are fatal will be present.***

### **2.3.9.6 Other Ac Wiring**

In addition to providing the high current primary ac voltage source for the NX200 Transmitter's power transformer, the breaker panel also provides separate ac feeds for other equipment in the transmitter system (see Figure 2-15 for the specific location for each ac feed cable in the breaker panel's top plate).

#### **NAX188 Surge Protection Panel:**

The Surge Box Kit (Nautel Part # 228-8310) from the Mains Equipment Kit contains a 228-8324 NAX188 Installation Kit, which contains the Teck90 wire (3-conductor plus ground, Nautel Part # WG54) and associated connecting hardware for ac wiring to the breaker panel.

Measure and cut sufficient wire length to route between the breaker panel and the surge protection panel. Route unterminated wires between the breaker panel's intended breaker and the surge protection panel.

#### NOTE

*For more information on installing Teck 90 cable and connectors, refer to the Teck Series Cable Fittings document in Appendix D.*

#### **PIE Cabinet and 4-Port Switch:**

Connect 1-phase ac wiring between the breaker panel and the PIE cabinet.

#### **Emergency Off Switch:**

Obtain the WE32 2-conductor wire from the Emergency Off Switch Wiring it (Nautel Part # 228-8326). Cut a suitable length of this wire to connect between the **EMERGENCY ON/OFF SWITCH** on the inside of the NX200 Transmitter (note there is also one in the front of the NX200 Transmitter) and the breaker panel. Access the switch wiring by routing wire through the top of the NX200 Transmitter. This connection provides a means to close a contact on the breaker panel, which applies a 130 V voltage to a coil that trips the main breaker. See Figures 2-23 and 2-24 for details.

#### **Exhaust Fan:**

Connect ac wiring (3-phase for NX200) between the breaker panel and the ventilations system's exhaust fan.

#### **Soda Load/Dry Cooler:**

Connect three-phase ac wiring between the breaker panel and the soda load and dry cooler (two separate breakers) as detailed in the soda load and dry cooler installation procedure.





Primary Wiring Kit 228-8322-01 Contents:

Qty	Part #	Description
4	HCT69	Cable Tray, Horz Elbow, 90 DEGx 12", 12" Rad
2	HCT73	Cable Tray, Vert Outside Elbow 12" x 90 Deg, 12" Radius
1	HCT50	Cable Tray Ladder, 12" Wide x144" Long
2	HCT53	Cable Tray Joining Plate C/WHardware
330	WT05	Wire, Diesel, 313 MCM, FT4 Tray Rated, OD=1.09
55	WT06	Wire, Diesel, 3/0, FT4 Tray Rated 90°C
24	HAM81	Connector, Mech, Lug, 300 MCM, M14 hole
4	HAM82	Connector, Mech, 3/0, M12 hole
16	HO59	Cleat, Cable, Trefoil for WT04 27 to 33mm DIA
16	HX69	Bracket, Mounting, Cable Cleat Aluminum Trays
1	HAH15	Tape, 3/4 W x 66 feet, Green, #35
1	HAH14	Tape, 3/4 W x 66 feet, Red, #35
1	HAH63	Tape, 3/4 w x 66 feet, Blue, #35
6	HAA92	Grip, Cord, 1.0-1.125
6	HAA70	Nut, Lock, Alum, for 1.25in Cord Grip (HAA69)
32	HMW16	Washer, Split, M12, SS
60	HM47	Washer, Flat, 316 SS, .562IDx1.25OD .05 THK
32	HMBH24	Bolt, Hex, M12 X 1.75 X 35LGSS
32	HMN08	Nut, Hex, M12 X 1.75, SS
20	HMBH03	Bolt, Hex, M8 X 1.25 X 30LGSS
40	HMW06	Washer, Plain, M8, SS
20	HMW14	Washer, Split, M8, SS
20	HMN06	Nut, Hex, M8 X 1.25, SS

Secondary Wiring Kit 228-8323-02 Contents:

Qty	Part #	Description
1	HCT50	Cable Tray Ladder, 12" Wide x144" Long
1	HCT76	Cable Tray, Horz T, 6"x12"x6", 12"R, 4" Deep
50	HT59	Tyrap, .190Wx14.5Lg Weather Resist., Black
1	HCT49	Cable Tray Ladder, 6" Wide x144" Long
1	HCT73	Cable Tray, Vert Outside Elbow 12" x 90 Deg, 12" Radius
1	HCT64	Cable Tray, Horizontal Tee, 12"x12"x6" 12" Rad
2	HCT72	Cable Tray, Vert Outside Elbow 6" x 90 Deg, 12" Radius
1	HCT54	Cable Tray End Plate, 6"
35	WT01	Wire I/O, Tray Rated, 90C, 600V, Green
70	WT02	Wire I/O Tray Rated, 90C, 600V, Black
210	WT04	Wire, Diesel, 535MCM, FT4 Tray Rated, OD=1.2", 2KV
11	HX69	Bracket, Mounting, Cable Cleat Aluminum Trays
2	228-8341	Cable Tray Joiner
11	HO59	Cleat, Cable, Trefoil for WT04 27 to 33mm DIA
40	HMBH03	Bolt, Hex, M8 X 1.25 X 30LGSS
80	HMW06	Washer, Plain, M8, SS
40	HMW14	Washer, Split, M8, SS
40	HMN06	Nut, Hex, M8 X 1.25, SS

Mains Equipment 228-8309-01 Contents:

Qty	Part #	Description
1	228-8322-01	Primary Wiring Kit, NX300
1	228-8323-02	Secondary Wiring Kit, NX300
1	UE183A	Breaker Panel, 800 A, shunt-trip, multi-breaker
1	228-8310	Surge Box Kit
1	228-8422	Ac Disconnect Assembly
1	228-8326	Emergency OFF Switch Wiring Kit

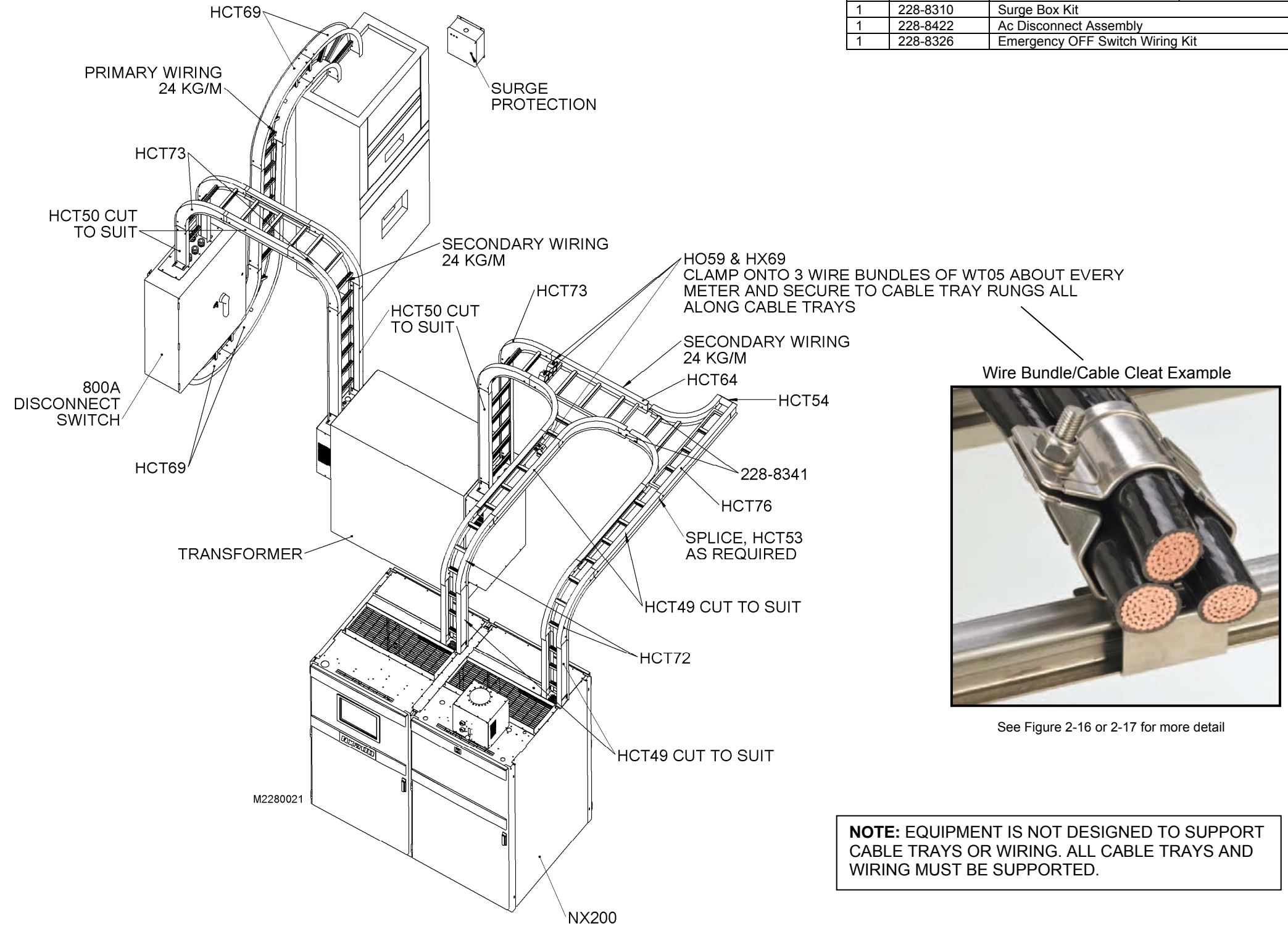

NX200 (Common) Mains Equipment - Primary (228-8322-01) and Secondary (228-8323-02) Wiring Kits

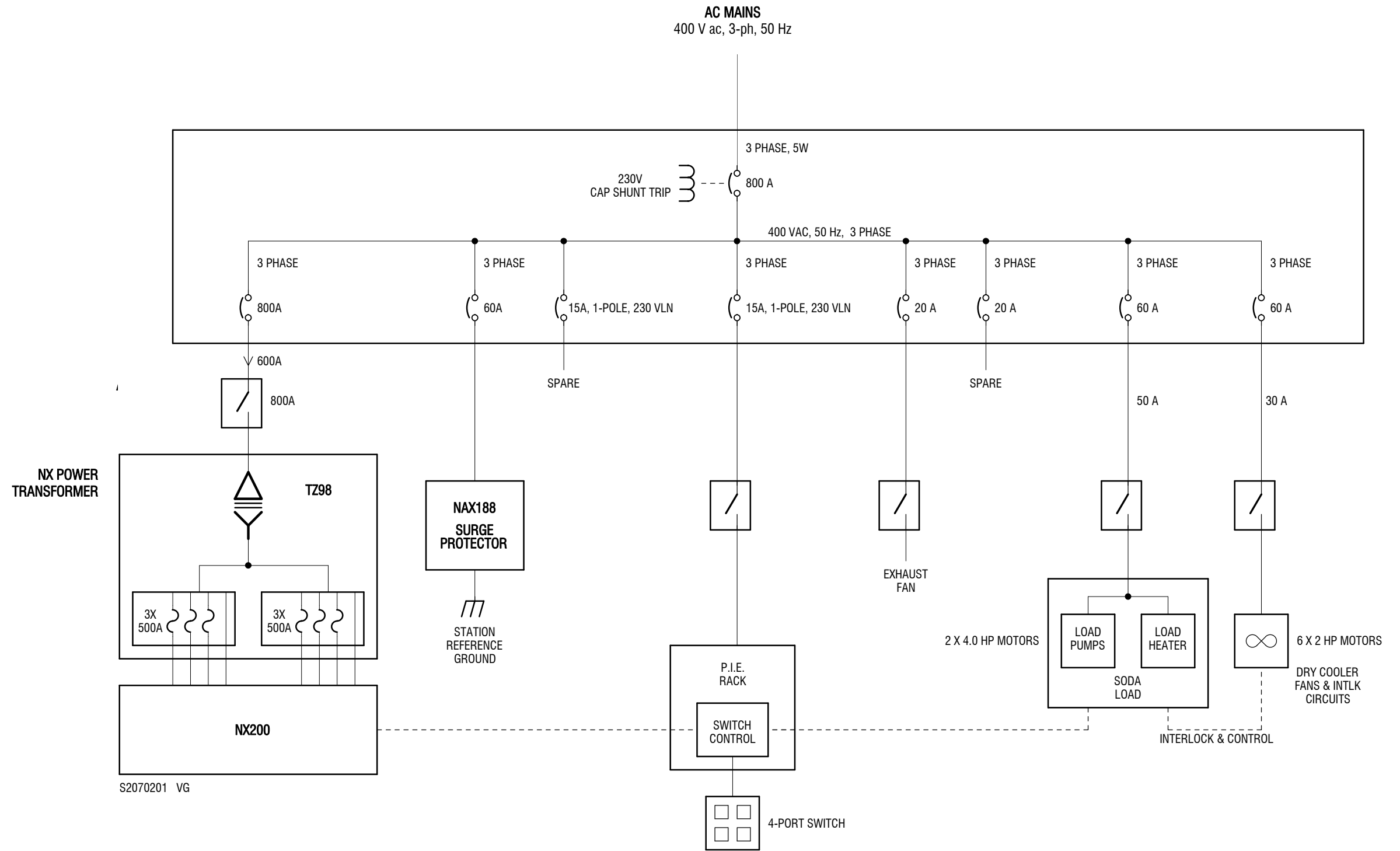

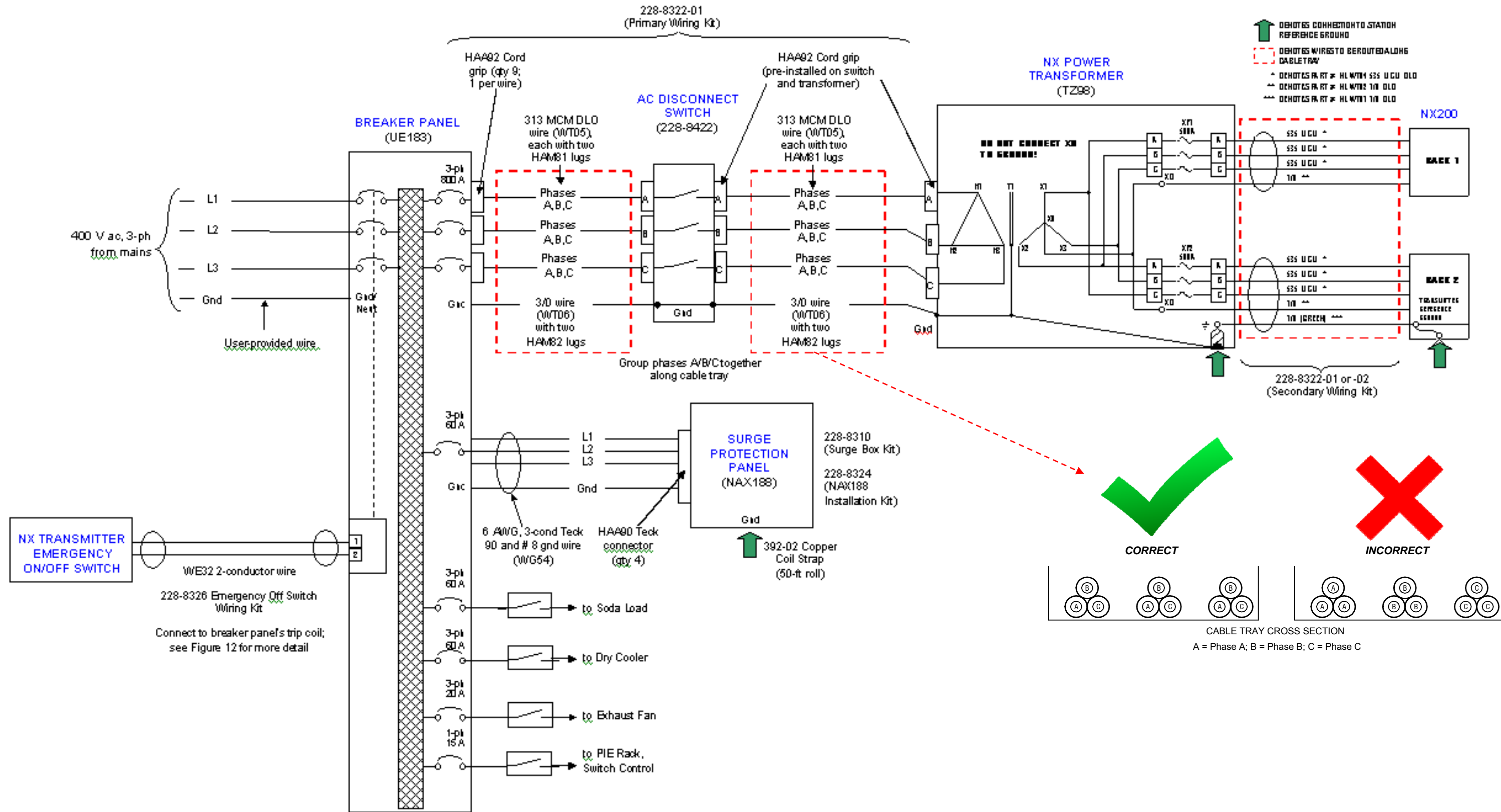

SCHEMATIC:

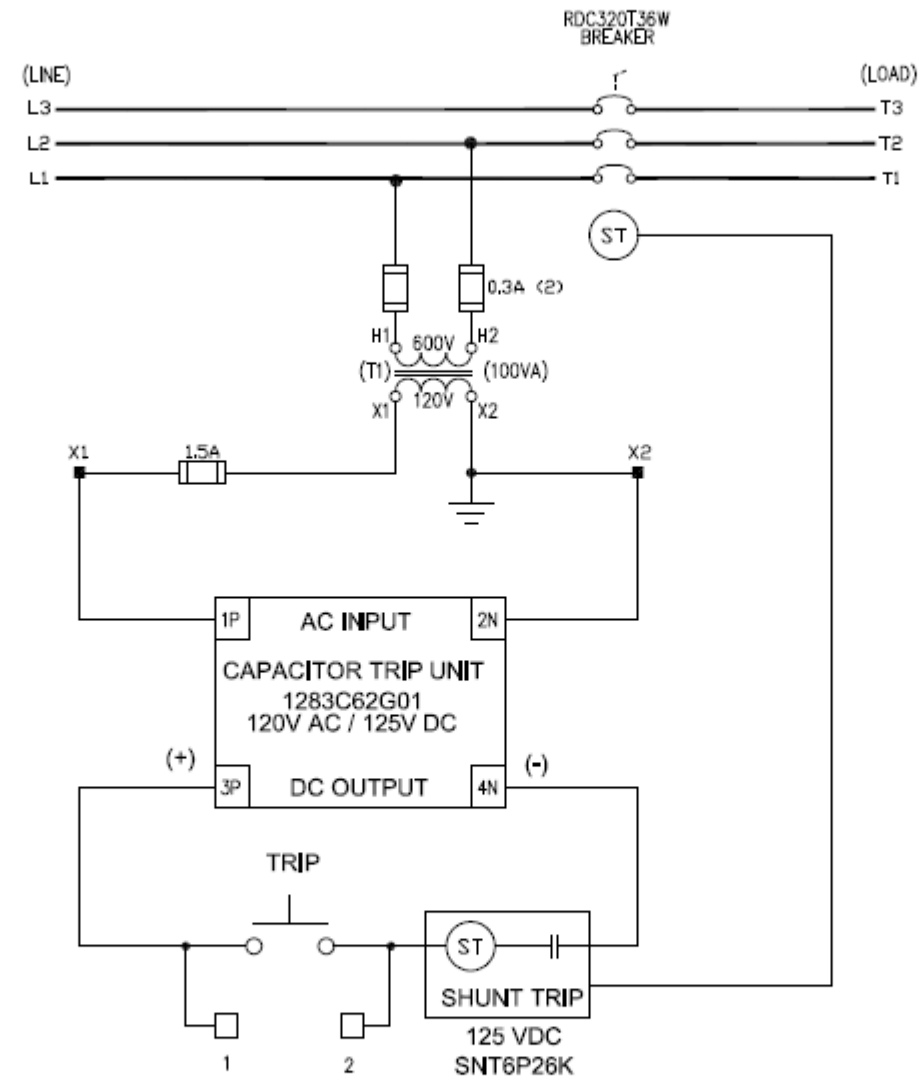

NOTES:

△ -CUSTOMER SUPPLIED REMOTE CONTROL

REVISION	1	<p>THE INFORMATION ON THIS DOCUMENT IS CREATED BY CUTLER-HAMMER. IT IS DISCLOSED IN CONFIDENCE AND IS ONLY TO BE USED FOR THE PURPOSE IN WHICH IT IS SUPPLIED.</p> <p>LES RENSEIGNEMENTS CI-DESSUS ONT ÉTÉ ELABORÉS PAR CUTLER-HAMMER. ILS VOUS SONT DIVULGUÉS EN TOUTE CONFIANCE ET LEUR UTILISATION SE LIMITE AUX SEULES FINS POUR LESQUELLES ILS VOUS SONT TRANSMIS.</p>	DFTR DESS.	DATE	Cutler-Hammer ONTARIO SATELLITE		
			T BARNES	11/23/09		TITLE	CAP TRIP CCT
				APPD APPR.	DATE	TITRE	CND312T36W
				APPD APPR.	SCALE	TYPE	CAP TRIP CCT
			NTS		SCHEMATIC		
		PRODUCT CODE	REVISION	DWG SIZE / ECHELLE	G.O.	DWG	PAGE
		CODE PRODUIT	1	A	c.g. CSD0029088	DESSIN	1 OF 1
						87-22104S	



Trip Circuit for Breaker Panel's Main Breaker  
Issue 0.3 Not to Scale Figure 2-24 Page 2-56

WARNING

**Ensure the main ac power source for the transmitter system is disabled or locked out before proceeding. If this is not observed, voltages that are fatal will be present.**

2.3.10 4-Port Switch, System Controller, IMU - Installation Tasks

Appendix References:

- Appendix A
- Appendix E

NOTE

*It is highly recommended you position **ALL** of the transmitter system's components in their final locations prior to installing cable trays, interconnecting wiring, plumbing, transmission line and ventilation.*

- (a) Unpack the 4-Port Switch Kit (see Table 2-8) and impedance matching unit (IMU) (see also Appendix E) for your NX200 Transmitter system. The 4-Port Switch Kit contains the 4-port switch (see Table 1), control/monitor assembly (228-2100) and interconnecting cable (W1, 228-2117).

Table 2-8: 4-Port Switch Kits and IMUs for each NX System

<b>System</b>	<b>4-Port Switch Kit #</b>	<b>4-Port Switch Part #</b>	<b>Switch Weight kg (lbs)</b>	<b>IMU Part # (see Appendix E)</b>	<b>IMU Weight kg (lbs)</b>
NX200	228-8306-01	228-6010-01	TBA (TBA)	228-6050-##	TBA (TBA)

- (b) Using necessary mechanical assistance (skyjack, etc.), position the 4-port switch on its pre-built user-provided support structure. Secure the 4-port switch to the support structure using the mounting holes in the switch base (see Figure 2-3 for hole locations).
- (c) Using necessary mechanical assistance (skyjack, etc.), position the IMU on its pre-built user-provided support structure. Secure the IMU to the support structure using the mounting holes in the IMU base (see Figure 2-4 for hole locations). Ensure that there is sufficient airflow path for the IMU's cooling fans.
- (d) Install the control/monitor assembly in its host cabinet. Secure it to the cabinet using four front panel screws.
- (e) See Transmission Line Installation (para. 2.3.11) for instructions to install the box-line between the 4-port switch, the NX200 Transmitter (via the IMU), the existing transmitter, the test load and the antenna system (via the RF output bushing box).

NOTE

*When installing the box-line between the 4-port switch and IMU, use your hand to support the inside of the IMU connector. You can gain access to this connector by removing an access cover in the bottom of the IMU. Re-install the access cover when installation is complete.*



- (f) Route interconnecting cable W1 (228-2117) between the control/monitor assembly (W1P1 end) and the 4-port switch (W1P2 end). Mate W1P1 to 25-pin D-sub connector J1 on the rear of the assembly, using a clearance hole in the top of the host cabinet for cable access. Mate W1P2 to K1J1 of the 4-port switch, using a clearance hole in the side of the switch for cable access. Temporarily remove the access cover to allow connector mating. See Figure 2-25 as a guide.
- (g) Locate the wiring (from kit) that was provided to make interlock connections to the rear of the control/monitor assembly. See Figure 2-26 for a rear view of the control/monitor assembly and Figures 2-27 and 2-28 for electrical schematics that shows the interlock connections. Connections are made to terminal blocks TB1 through TB3 on the rear of the control/monitor assembly. The terminals accept wire sizes between 12 and 24 AWG. Route cables neatly and connect as follows:

#### NOTE

*When it is safe to produce an RF output, an interlock circuit must provide a short (low impedance). When it is not safe to produce an RF output (one or more of the external interlock switches have been activated), the circuit must provide an open. Any number of serial interlock switches may be installed, provided they present an open circuit if any interlock switch is activated.*

*If the **RF** toggle switch on the control/monitor assembly's front panel (see Figure 3) is set to **INHIBIT**, all interlock circuits will be open and RF power for the entire transmitter system will be inhibited.*

- **SYSTEM INTERLOCK:** Provides an interlock for the entire transmitter system. If the system interlock is open, both transmitters are interlocked off. If used, install a suitable length of shielded cable between terminals TB2-3 (core) and TB2-4 (shield) of the control/monitor assembly and the external system interlock circuit. This connection allows you to connect an external safety interlock circuit that provides an emergency RF inhibit control for the transmitter system. If the system interlock is not used, install a shorting jumper between TB2-3 and TB2-4.

#### WARNING

*If a jumper is placed between the **SYSTEM INTERLOCK** terminals (TB2-3 and TB2-4), safety features provided by the external interlocks will be disabled. A fail-safe method of alerting personnel to this fact should be implemented. Voltages that are dangerous to life will be present on RF output stages and the antenna system if a transmitter is turned on.*

- **CUSTOMER INTERLOCK:** Provides an additional option for the customer to connect in series with the system interlock circuit. As desired, install a suitable length of shielded cable between terminals TB2-5 (core) and TB2-6 (shield) of the control/monitor assembly and the customer interlock circuit. This connection allows you to connect an optional safety interlock circuit that provides an emergency RF inhibit control for the transmitter system. If it is not used, it must be shorted by a jumper to keep the system interlock circuit intact.





## WARNING

**Ensure the main ac power source for the transmitter system is disabled or locked out before proceeding. If this is not observed, voltages that are fatal will be present.**

- **TEST LOAD INTERLOCK:** Provides an interlock for the test load. If the test load interlock is open, the transmitter routed to the test load is interlocked off. Install a suitable length of shielded cable between terminals TB2-7 (core) and TB2-8 (shield) of the control/monitor assembly and the test load's interlock connection (see para. 2.3.7 for details on the test load).
- **XMTR A INTERLOCK:** Provides an interlock for the NX200 Transmitter (transmitter A). If a system interlock or the test load interlock is open, or if the RF contactor has not completed a transfer, transmitter A is interlocked off. Install a suitable length of 2-conductor shielded cable (WE32) between terminals TB1-1 and TB1-2 of the control/monitor assembly and transmitter A's interlock circuit (A11A1J6, see the NX200 Transmitter manual for details).
- **XMTR B INTERLOCK:** Provides an interlock for the existing on-site transmitter (transmitter B). If a system interlock or the test load interlock is open, or if the RF contactor has not completed a transfer, transmitter B is interlocked off. Install a suitable length of 2-conductor shielded cable (WE32) between terminals TB3-1 and TB3-2 of the control/monitor assembly and transmitter B's interlock circuit (see the transmitter's instruction manual for details).
- **XMTR A ALARM:** Provides a means to audibly monitor faults in transmitter A. Install a suitable length of shielded cable between terminals TB1-3 (core) and TB1-4 (shield) of the control/monitor assembly and pins 2 (core) and 1 (shield) of J5 of transmitter A's remote interface PWB (A11A4). If the **MUTE** toggle switch on the control/monitor assembly's front panel (see Figure 3) is not set to **MUTE**, you will hear an audible alarm when a fault occurs on transmitter A. If the toggle switch is not set to **MUTE**, the audible alarm will be disabled.





**NX200 SYSTEMS**

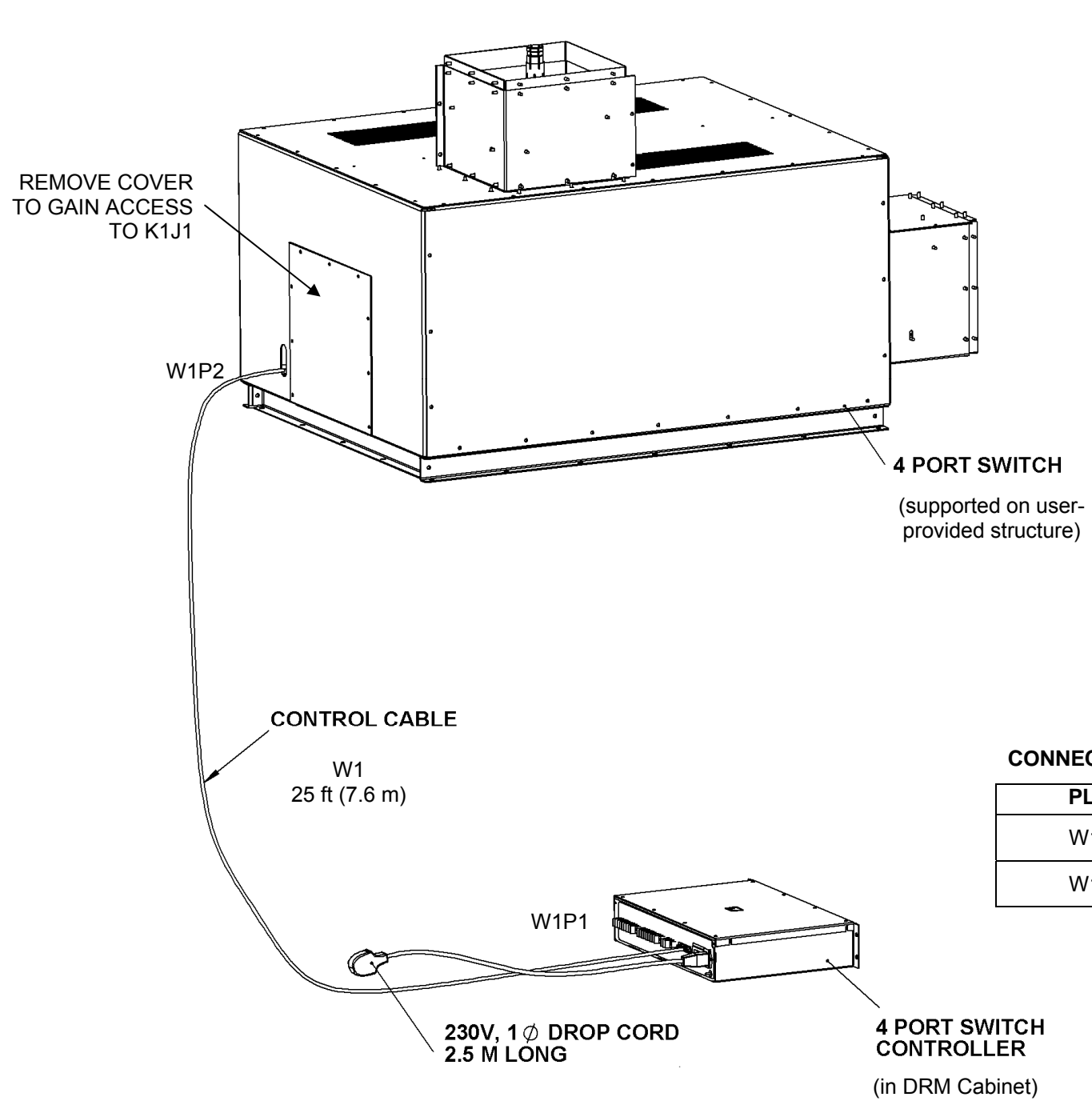

**CONNECTOR MATING INFORMATION**

PLUG	MATE
W1P1	Controller - J1
W1P2	4-Port Switch - K1J1

**NX300 and NX100 SYSTEMS**

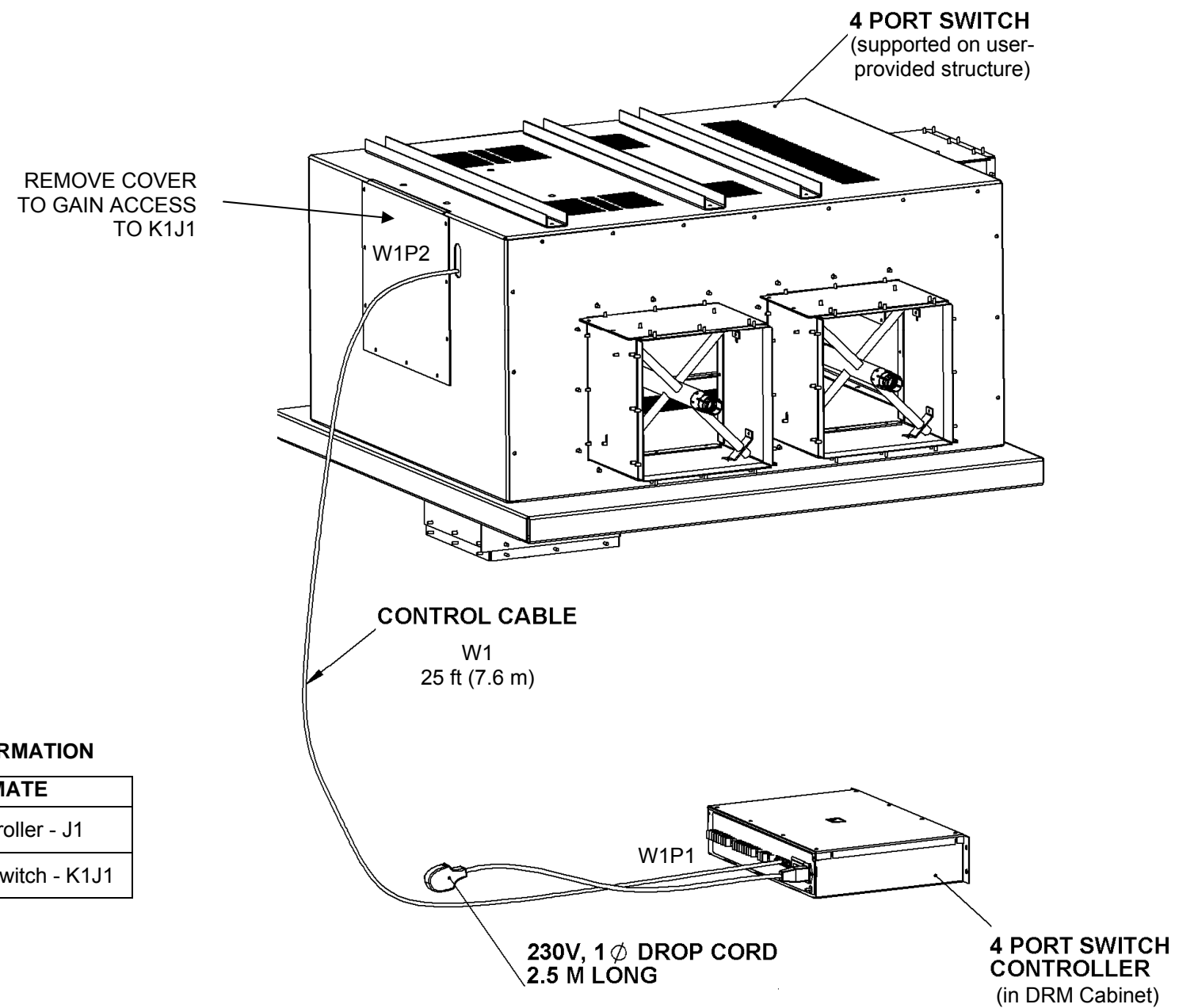

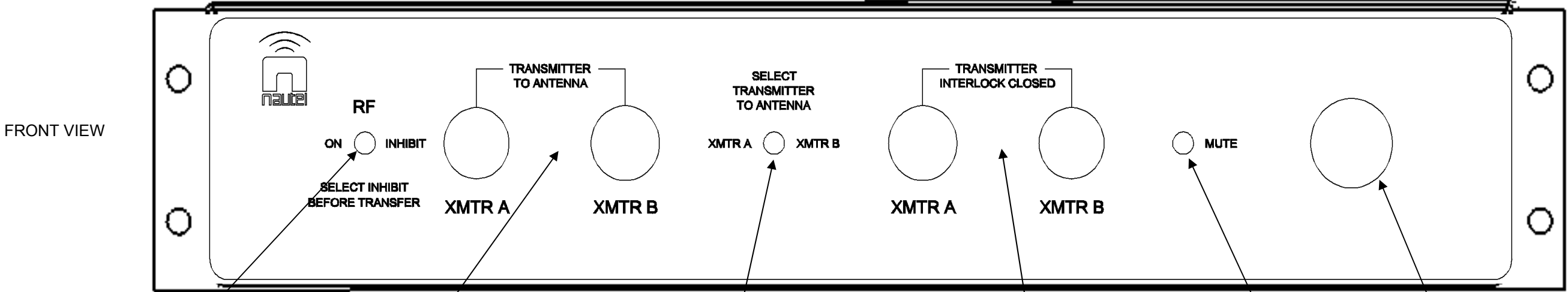
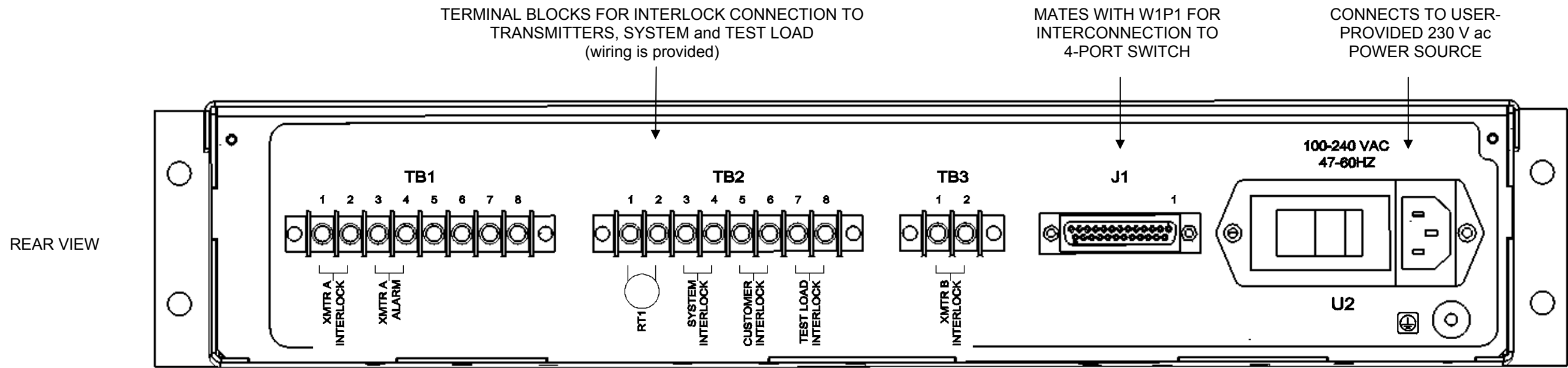

**TOGGLE SWITCH**  
 Set to **ON** to close the interlock circuit and enable RF power.  
 ALWAYS set to **INHIBIT** to open the interlock circuit and inhibit RF power prior to performing a transfer.

**LED PILOT LIGHTS (AMBER)**  
 The appropriate transmitter LED (**XMTR A** or **B**) turns on when that transmitter's RF output has successfully been routed to the antenna, as determined by the **SELECT TRANSMITTER TO ANTENNA** toggle switch position.

**TOGGLE SWITCH**  
 Set to **XMTR A** to initiate a transfer to route transmitter A's RF output to the antenna (transmitter B's RF output to the test load). The **XMTR A** LED will turn on when the transfer is complete.  
 Set to **XMTR B** to initiate a transfer to route transmitter B's RF output to the antenna (transmitter A's RF output to the test load). The **XMTR B** LED will turn on when the transfer is complete.

**LED PILOT LIGHTS (AMBER)**  
 The appropriate transmitter LED (**XMTR A** or **B**) turns on when that transmitter's interlock circuit is closed (intact) and it is safe to apply RF output power.

**TOGGLE SWITCH**  
 Set to **MUTE** to silence the audible alarm.

**AUDIBLE ALARM**  
 Emits an audible alarm (when the **MUTE** switch is not activated) to indicate a fault is occurring in transmitter A (NX200 Transmitter).



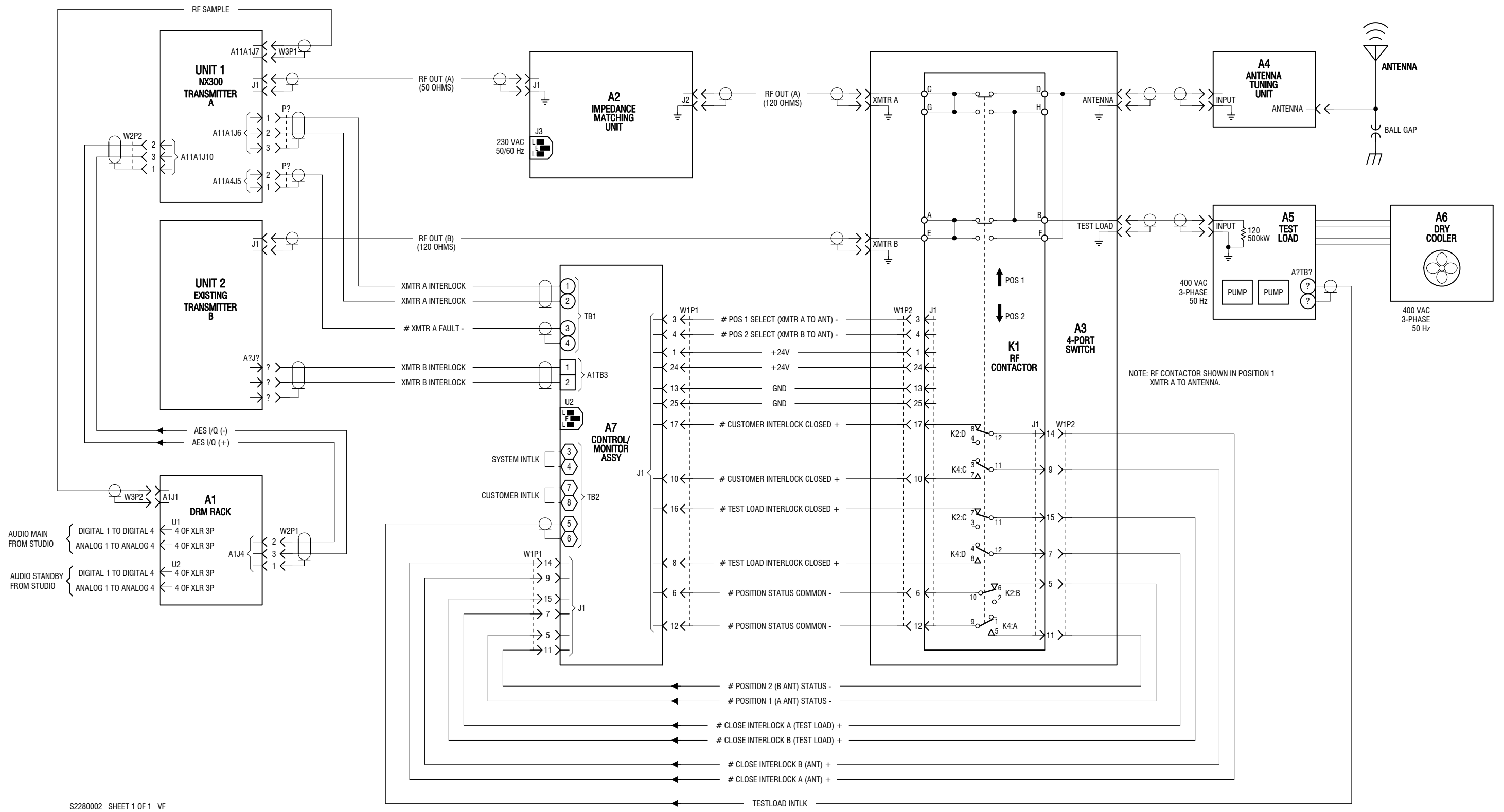

S2280002 SHEET 1 OF 1 VF



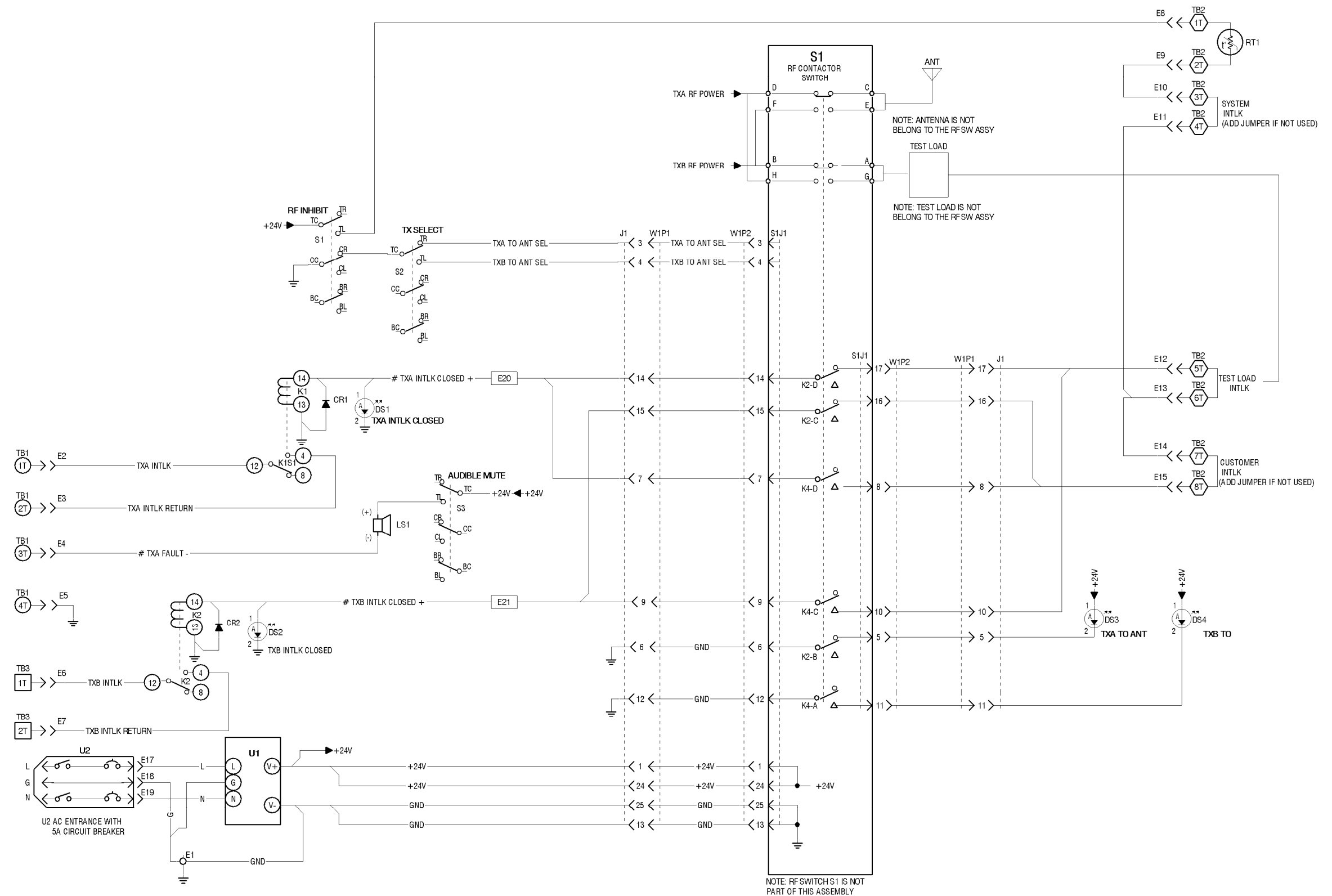

Electrical Schematic - Control/Monitor Assembly (228-2100)  
 Issue 0.3      Not to Scale      Figure 2-28      Page 2-64



### 2.3.11 Transmission Line - Installation Tasks

The following installation procedures should be performed by qualified technical personnel.

#### Appendix References:

- Appendix A
- Appendix F

#### NOTE

*It is highly recommended you position **ALL** of the transmitter system's components in their final locations prior to installing cable trays, interconnecting wiring, plumbing, transmission line and ventilation.*

*The system's transmission line should be installed before the ventilation system given the area constraints at the top of the NX200 transmitter.*

- Unpack the Transmission Line Kit for your NX200 Transmitter system. The Transmission Line Kit (see Table 2-9) contains the coaxial hard-line (6-1/8 inch for NX200 systems) to interconnect the NX200 Transmitter's output and IMU input and the 120-ohm box-line to interconnect the IMU output, 4-port switch, existing on-site transmitter, test load and antenna.

Table 2-9: Nautel Supplied Transmission Line Kits

Transmitter System	Transmission Line Kit #
NX200 System	228-8307-01

- Unpack the site corresponding transmission line kits (see Figure 2-5 to determine the specific kit numbers) and confirm that all parts have been included.
- Cut and install 50-ohm line (from hard-line kit) on supports (see Figure 2-31 for details).
- Assemble the 18 box-line 4 ft sections, (Nautel Part # 228-6040 from box-line kit) and perform cuts where required. See Figure 2-29 for detailed section layout
- Assemble the eight box-line elbow sections (Nautel Part # 228-6030 from box-line kit). See Figure 2-30 for detailed elbow section layout.
- Install the box-line sections on its user-provided supports, as detailed in the pre-installation considerations.
- Install/mount output bushing box (Nautel Part # 228-6046) in the 1.17 m x 1.17m opening in the exterior wall and plate style feed-through.
- Connect the coaxial hard-line between the NX200 Transmitter and IMU.
- Connect box-line between the IMU and the 4-port switch; between the 4-port switch and transmitter B (existing on-site transmitter); between the 4-port switch and the output bushing box; between the 4-port switch and the test load.







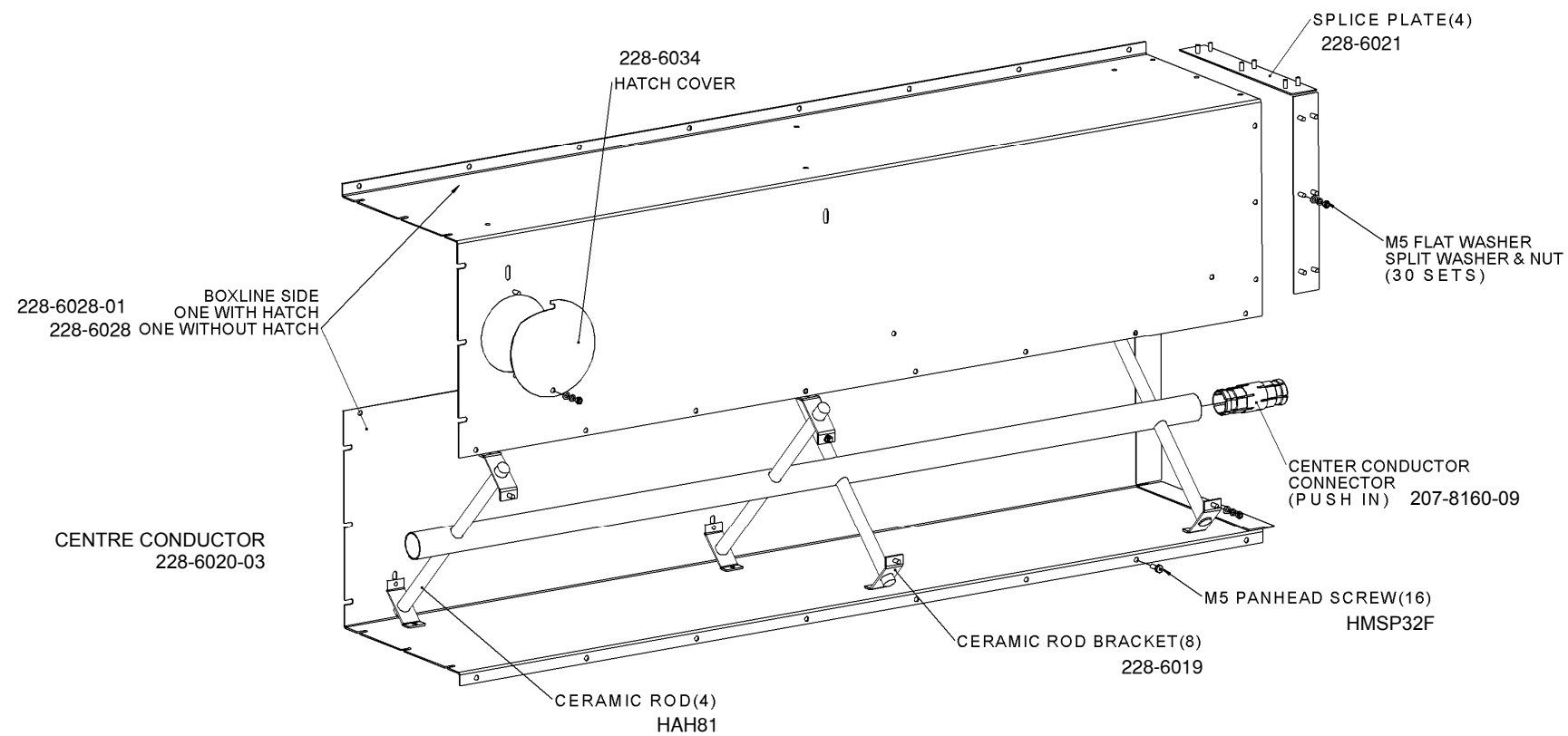

Box-line 4 ft. Section Kit (Nautel Part # 228-6040):

Qty	Part #	Description
1	207-8160-09	CONNECTOR DET ASSY, SILVERPLATED
8	228-6019	CERAMIC ROD BRACKET
1	228-6020-03	CENTER CONDUCTOR
4	228-6021	SQ COAX SPLICE
1	228-6028	BOXLINE SIDE
4	HAH81	ROD, CERAMIC, .625"OD X 13.86" LONG, GLAZED STEATITE
1	228-6028-01	BOXLINE SIDE WITH HATCH
1	228-6034	BOXLINE HATCH COVER
16	HMSP32F	SCREW,PAN,PHIL,M5X0.8X16LG,SSC/W SPLIT & FLAT
55	HMN04	NUT, HEX, M5 X 0.8, SS
55	HMW04	WASHER, PLAIN, M5, SS
55	HMW34	WASHER, SPLIT, M5, SS

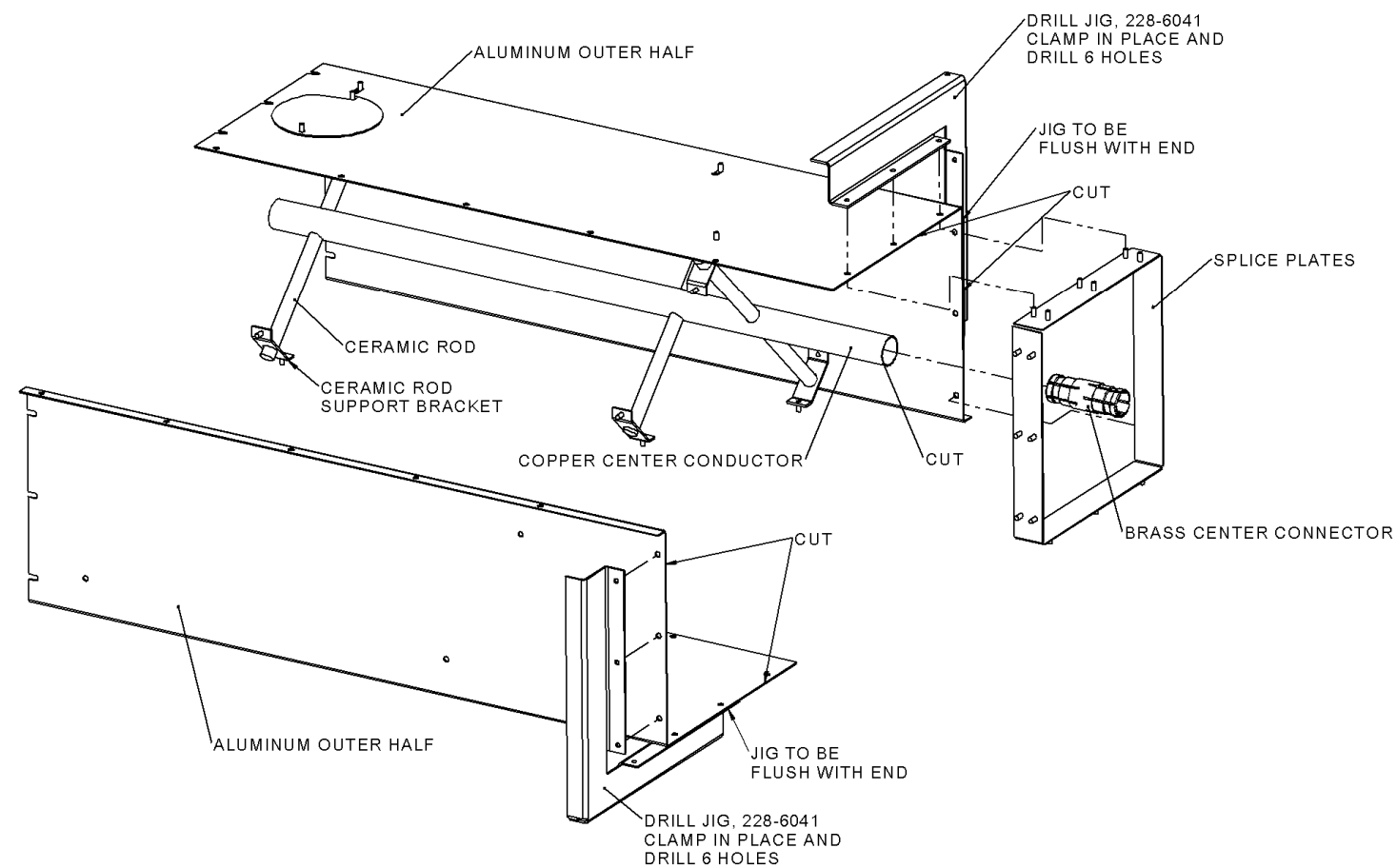

**Boxline Cutting Procedure**

- 1: Determine the length to which the box line is to be cut
- 2: Dis-assemble the 4 foot (1220 mm) section of box line
- 3: Measure and scribe the cut in each of the two box line aluminum outer halves. Measure from and retain the box line portions with the 12 slots. Remove unwanted material from the ends of the box line halves with the 12 holes only. Drill out and remove any captive fasteners in the flange which will interfere with the cut. Using the hacksaw supplied, cut the aluminum halves. Ensure cut is perpendicular to the axis of the copper center conductor. Using the file supplied, deburr cut and remove any swarth. If the cut falls on the same location as a ceramic rod or ceramic rods are left in the unwanted portion, discard the ceramic rods and associated brackets.
- 4: Place and clamp hole drill jig (228-6041) with clamps supplied on each of the modified ends of the aluminum outer halves and drill 12 - 0.213 (5.4mm) diameter holes (drill supplied). Ensure jig is clamped on flush to cut edge. Deburr holes and remove any swarth.
- 4: Using the hacksaw, cut the same length of material from the end of the center conductor as that which was removed from the aluminum outer halves. Deburr cut and remove any swarth.
- 5: Re-assemble box line

**Tools and jig are in box line cutting kit (Nautel Part # 228-6042)**



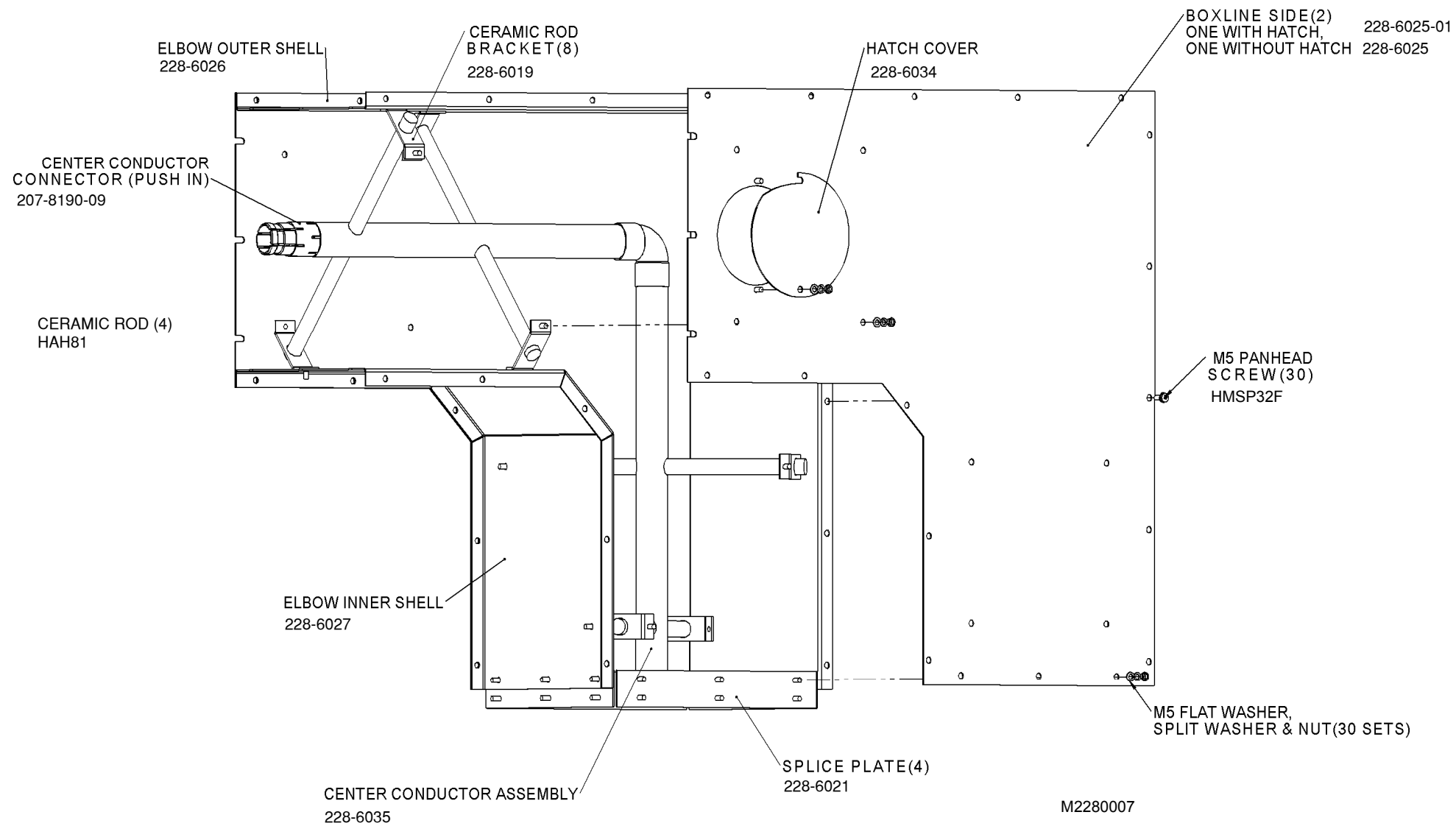

Box-line Elbow Kit (Nautel Part # 228-6030):

Qty	Part #	Description
1	207-8160-09	CONNECTOR DET ASSY, SILVERPLATED
8	228-6019	CERAMIC ROD BRACKET
1	228-6035	BOXLINE ELBOW CENTER COND ASSY
4	228-6021	SQ COAX SPLICE
1	228-6025	SQ COAX ELBOW SIDE
1	228-6026	SQ COAX ELBOW OUTSIDE
1	228-6027	SQ COAX ELBOW INSIDE
4	HAH81	ROD, CERAMIC, .625"OD X 13.86" LONG, GLAZED STEATITE
1	228-6025-01	SQ COAX ELBOW SIDE
1	228-6034	BOXLINE HATCH COVER
35	HMSP32F	SCREW,PAN,PHIL,M5X0.8X16LG,SSC/W SPLIT & FLAT
40	HMN04	NUT, HEX, M5 X 0.8, SS
40	HMW04	WASHER, PLAIN, M5, SS
40	HMW34	WASHER, SPLIT, M5, SS



## Standard Coaxial Line Cutback Dimensions

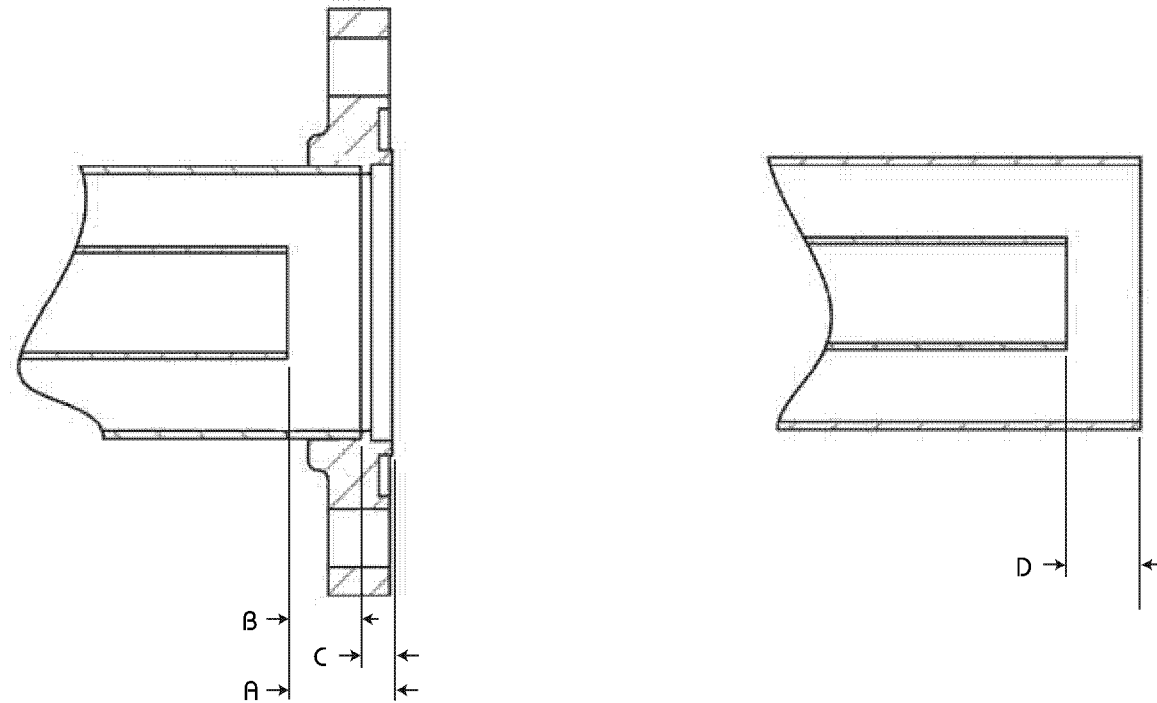

Nominal Line Size	7/8" 50-Ω	1-5/8" 50-Ω	3-1/8" 50-Ω	4-1/16" 50-Ω	6-1/8" 50-Ω
A	0.500" +0 -0.03"	0.625" +0 -0.03"	0.937" +0 -0.03"	1.375" +0 -0.03"	1.343" +0 -0.03"
B	0.344" ± 0.02"	0.438" ± 0.02"	0.687" ± 0.02"	1.125" ± 0.03"	1.063" ± 0.03"
C	0.156"	0.187"	0.25"	0.25"	0.28"
D	0.344" ± 0.02"	0.438" ± 0.02"	0.687" ± 0.02"	1.125" ± 0.03"	1.063" ± 0.03"

## Cutback and Installation of Shively Hard Line (indoor only):

### Required tools:

- Reed tube cutter TC3Q: 3/8" to 3 1/2" - require 1 Pc.
- Reed tube cutter TC6Q: 4" to 6 5/8" - require 1 Pc.
- Replacement cutter wheels, Reed part #63665 - 2PK-30-40 require 4 pack (8 wheels).
- Deburring tools Reed DEB3, require 1 Pc minimum.
- Replacement blade for DEB3, require 2 pack (20 blades).
- 3M industrial scotch bright pad require 40 paces.
- Copper files set: round, half round and flat.
- Cotton cloths for cleaning.

### Cutting tips:

- Cover both ends with plastic wrap to keep components clean and protected.
- Used gloves while handling the hard line and components to avoid hand grease.
- Avoid bending the hard line and refrain from using any parts that have been bent.
- Ensure there is inner teflon support in you cutting size.
- Check the screws on elbow sections and couplings to ensure they are tight before installation.
- Cut straight, smooth and clean.
- Put a clean cloth inside the tube before cutting to avoid swarf entering the line. Ensure that cutting wheels (or alternatively hacksaw blades) are appropriate for cutting copper.
- After cutting, use a scotch bright pad to clean and smooth the cutting area.

### Cutting and installation (for use with non-pressurized indoor hard line):

- Follow the manufacturer's instructions.
- Draw a pencil line where the flange or coupling should reach when assembled (based on manufacturer's instructions). This will ensure a secure fit when pieced together.
- Starting from a fixed reference point (transmitter output), perform the outer vertical cut first, then clean the cut end.
- Perform the inner cut according to the Shively instructions (inner cut piece always shorter than the outer cut piece), clean the cut end, and install the anchor connector. Assemble the flange with the outer cut piece and tighten the flange screw (be sure there is sufficient Teflon spacer between inner and outer pieces). Check the rigid line vertically with a level.
- Install a vertical support if required (typically used for sections longer than 1.2 meters).
- Install coupling in the other vertical end and install the elbow section. Tighten the coupling screws well.
- Continue assembly of horizontal hard line sections and supports.

### Maintenance:

- During operation and routine maintenance, check the hard line outer temperatures (especially elbow and coupling sections) for any heat.
- During maintenance, check that the elbow and coupling sections remain securely tightened.
- Keep the assembled pieces clean.

Cutting and Installation Tips for Coaxial Hard-Line (indoor only)			
Issue 0.3	Not to Scale	Figure 2-31	Page 2-69 (2-70 Blank)

WARNING

***It is strongly recommended that the installation of all ventilation system elements be performed by licensed air-handling personnel.***

2.3.12 Ventilation (Air Handling) System - Installation Tasks

The following installation procedures should be performed by qualified technical personnel.

Appendix References:

- Appendix A
- Appendix G

NOTE

*It is highly recommended you position **ALL** of the transmitter system's components in their final locations prior to installing cable trays, interconnecting wiring, plumbing, transmission line and ventilation.*

*The system's transmission line should be installed before the ventilation system given the area constraints at the top of the NX200 transmitter (see Figure 2-33).*

- (a) Unpack the appropriate ventilation kit (see Table 2-10 to determine the specific kit numbers) and confirm that all parts have been included.

Table 2-10: NauteI Supplied Ventilation Kits

System	Ventilation System Kit #	See Figure #
NX200 (Common)	228-8311-02	2-6

- (b) Assemble the rectangular hood tie-in duct work accordingly (see Figure 2-36).
- (c) Cut holes in the rectangular hood tie-in according to the required offset (see Figure 2-36).
- (d) Cut hood spirals to size as required (see Figure 2-36).
- (e) Install the user-provided supports for the ventilation system, as detailed in the pre-installation considerations
- (f) Assemble and install main spiral ductwork including take offs, canvas sections and fittings (see Figure 2-36).
- (g) Orient the exhaust fan assembly motor and install 6000 CFM exhaust fan (see data sheets in Appendix G).
- (h) Assemble and connect all hood elements (see Figure 2-36).
- (i) Verify suitable sized holes have been cut in the appropriate wall locations for the inlet/damp filter assembly and air exhaust (see pre-installation considerations).
- (j) Install inlet from ventilation kit.
- (k) Install air exhaust from ventilation kit.



- (l) Install the exhaust louvre and damper motors (see datasheets in Appendix G).
- (m) Install the reverse thermostat (see datasheet in Appendix G).
- (n) Route and install the wiring for the fan (3-phase), damper motors (3-phase), and thermostat (see Figure 2-32).
- (o) Install the vibration isolators as required noting the different sizes for each fan (see data sheets in Appendix G and Figure 2-35).



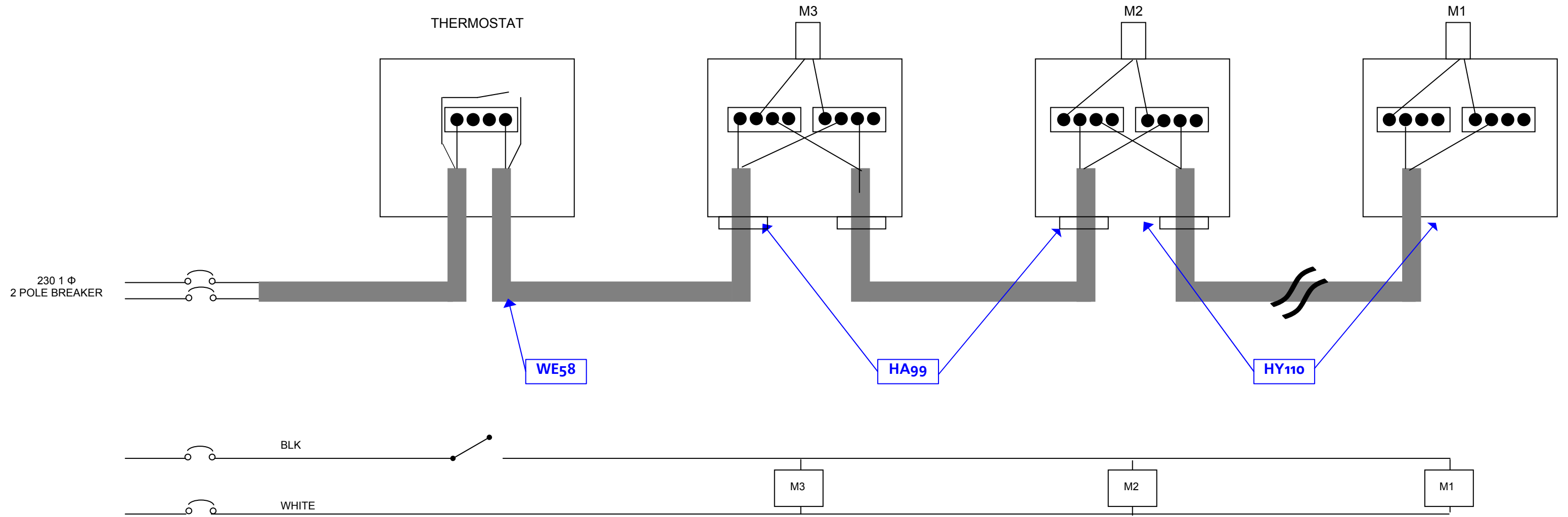

NX System HVAC Wiring

1	228-8328	HVAC Wiring Kit
100 FT	WG52	WIRE, TECK90, 10AWG, 3 STRAND+ #12AWG GROUND WIRE, 600V
4	HAA83	CONN, TECK, 3X10AWG, ALUMINUM
1	SA80	SWITCH, DISCONNECT, 63A, 3 POLE, ABS HOUSING, IP66
4	HAA99	NUT, ALUM, 1/2" CONDUIT
250 FT	WE58	WIRE, 18AWG, 2 COND, JACKETED, 90°C EPDM
8	HAA99	GRIP, CORD, 3/8, STRAIGHT, NON-METAL
8	HL52	NUT, 3/8 FOR LAPP 52138
4	HY110	BOX, JUNCTION, NON-METAL, 4"X4"X2", W/LID
10	HV46	CONNECTOR, 5 WIRE, 28-12 AWG, CONNECTOR, 5 WIRE, 28-12 AWG,



Thermostat Wiring Diagram

Issue 0.3	Not to Scale	Figure 2-32	Page 2-73
-----------	--------------	-------------	-----------



**A**  
Side View showing constrained area at top of NX200 transmitter.



**B**  
Exhaust fan assembly (with motor at bottom orientation)  
U1B Mounts – Hanging Style

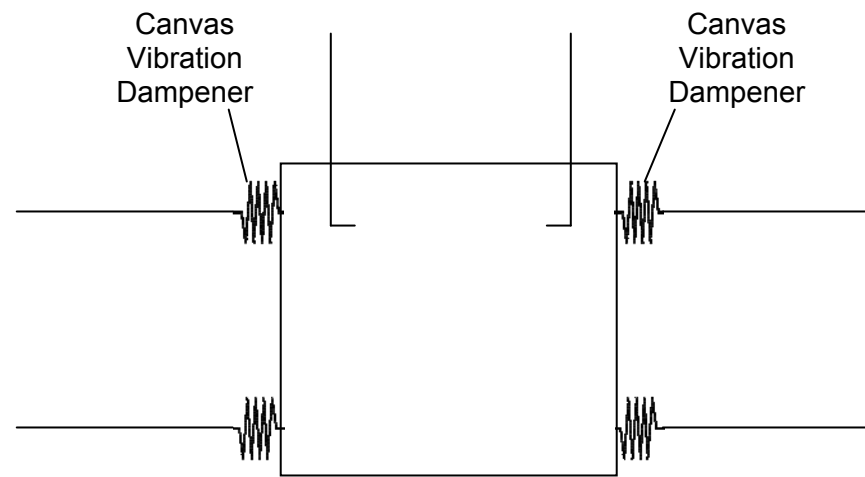
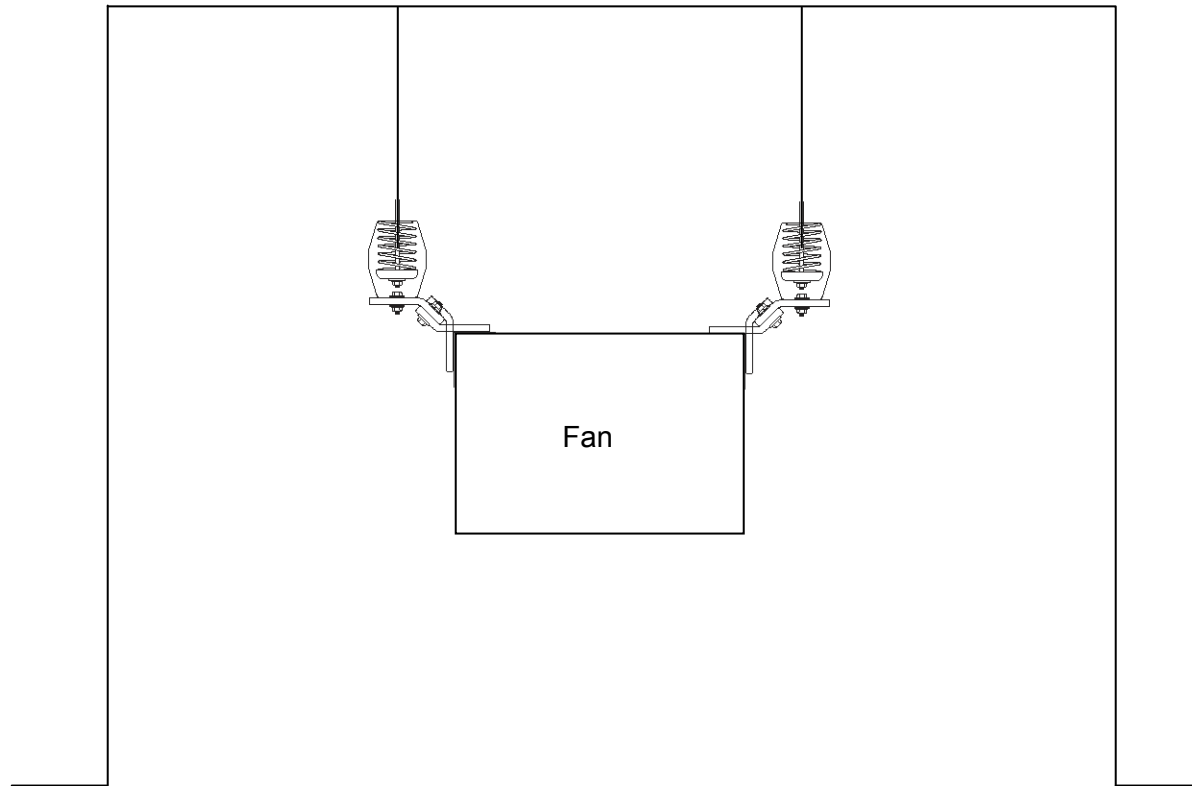

## HANGING SUPPORT ISOLATOR

Note: Top bracket is reversible for mounting unit 90° from indicated. (SQ and BSQ only)

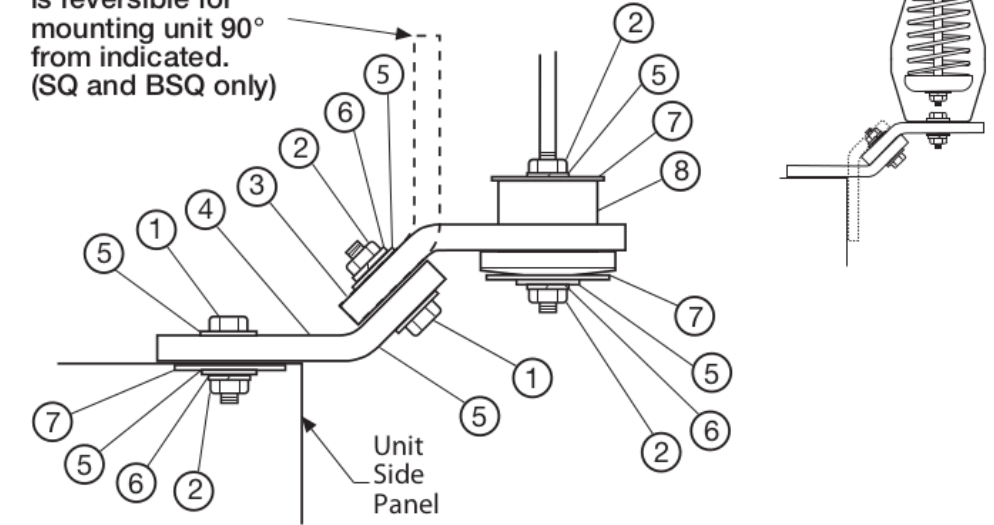

No	Qty	Description	SQ-60 thru 140 BSQ-100 thru 140 BDF-80 thru 150	SQ-160 BSQ-160 thru 420 BDF-180 thru 200
1	8	Cadium plated hex head bolts	3/8 in. - 16 x 1 in.	3/8 in. - 16 x 1 1/4 in.
2	16	Cadium plated hex nuts	3/8 in. - 16	3/8 in. - 16
3	4	St. mount bracket w/1 - 1/4 in hole	3/16 in.	1/4 in.
4	4	St. mount bracket w/2 - 7/16 in. holes	3/16 in.	1/4 in.
5	24	Cadium plated washer	7/8 in. O.D x 3/8 in. I.D. x 1/16 in.	7/8 in. O.D x 3/8 in. I.D. x 1/16 in.
6	12	Cadium plated lock washer	3/8 in.	3/8 in.
7	12	Cadium plated washer	1 3/8 in. O.D x 9/16 in. I.D. x 3/32 in.	1 3/8 in. O.D x 9/16 in. I.D. x 3/32 in.
8	4	Neoprene or Spring Isolator	Reference appropriate table below for replacement Isolator(s)	

Hanging Vibration Isolator Assembly with Typical Installation Configuration (required for vibration and noise reduction)

Issue 0.3

Not to Scale

Figure 2-35

Page 2-76



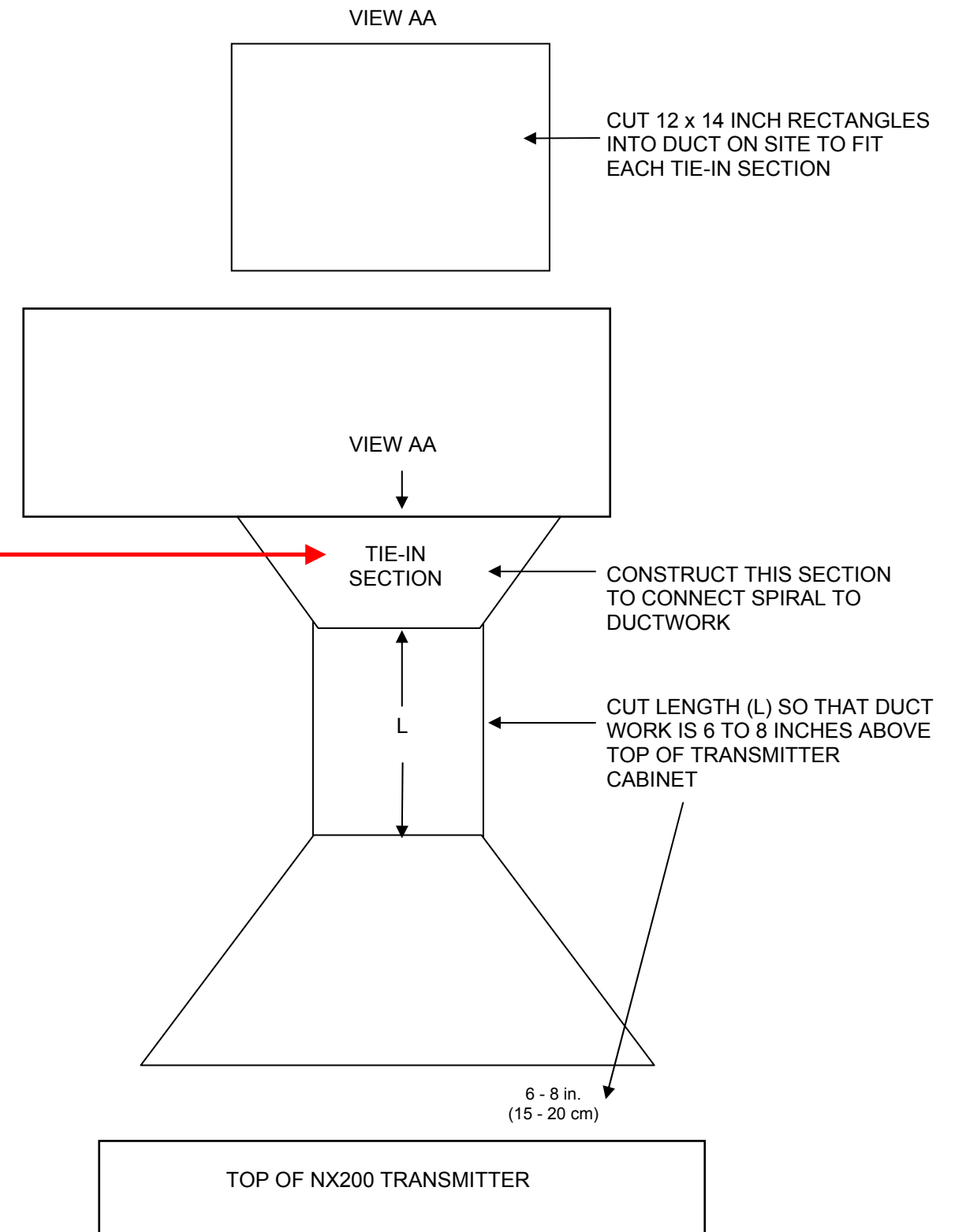

### WARNING

**Ensure the main ac power source for the transmitter system is disabled or locked out before proceeding. If this is not observed, voltages that are fatal will be present.**

#### 2.3.13 Miscellaneous Installation Tasks

- (a) Configure the primary winding taps for the NX200 Transmitter's power transformer as detailed in section 4 of the *NX Installation Manual*.
- (b) Install the station reference ground connections. Connect low-impedance conductors (00 AWG copper wire, four-inch copper strap or equivalent), as described in the 'Lightning Protection for Radio Transmitter Stations' section of Nautel's *Recommendations for Transmitter Site Preparation* booklet, between the station reference ground point and the station reference ground connection on the NX200 Transmitter. See also section 4 of the *NX Installation Manual*. Repeat this type of connection between the station reference ground and other critical points in the transmitter system.

### NOTE

*For best lightning protection, the station reference ground connections to the NX200 Transmitter and other points should not be shared. There should be a completely separate connection between the station reference ground point and each component.*

- (c) Adjust the NX200 Transmitter's RF output spark gap as detailed in section 7 of the *NX Installation Manual*.



## 2.4 KEY SEQUENCE SYSTEM

Each transmitter system has a distinct key sequence system. This is provided to prevent operators and maintainers from being exposed to dangerous voltages when opening doors and panels of the transmitter system. This section describes how to use the key controlled system to safely access the transmitter system.

### WARNING

***Failure to follow the steps listed in the KEY SEQUENCE procedures below, or attempting to bypass the keyed interlock system will permit access to lethal voltages.***

### NOTE

*Keys used in any of the transfer cases that provide access to the transmitter, ATU or third-party equipment become sealed in the transfer case when they have been turned and any of the access keys are taken. Identification of locks and keys are stamped (indented) on the keys and locks themselves.*

The NX200 system is described in 2.4.1 and Figure 2-37.



## WARNING

**Ensure the main ac power source for the transmitter system is disabled or locked out before proceeding. If this is not observed, voltages that are fatal will be present.**

### 2.4.1 NX200 Main-Standby Transmitter Systems

Follow the steps below to ensure safe access to the interior of the NX200 transmitter and ATU hut. See Figure 2-37 for the key sequence diagram that supports this procedure.

#### **NX200 Access**

Follow these steps to safely gain access to the inside of transmitter A (NX200):

- (a) Switch off the ac power at the NX200's Main AC Cutoff (Ac Disconnect) switch. Turn Interlock Key 'A' to lock the ac power handle in the 'Off' position, releasing the 'A' key.
- (b) Insert the 'A' key into the 'A' lock in the Antenna Ground Switch on top of the NX200's output cabinet. Turn the 'A' key, engage the antenna grounding handle, turn the 'B' key, locking the ground handle in place and pull out the 'B' key. This locks the Antenna Ground Switch in the ground position and locks in the 'A' key.
- (c) Insert the 'B' key into the six-key transfer case in the NX200's output cabinet, which releases the five 'C' keys. Four 'C' keys allow access into NX200 through the rear doors and into the filter through the front inner doors. The fifth 'C' key is required to unlock the ATU tuning hut.

#### **Full System Access**

In additional to steps (a) through (c), follow these steps to safely gain full system access:

- (d) Switch off the ac power to the existing (old) transmitter at its Main AC Cutoff Switch (Ac Disconnect Switch). Install the 'D'-keyed padlock and lock the ac power handle in the 'Off' position. This releases the 'D' key.
- (e) Insert a 'C' key from the NX200 six-key transfer case and the 'D' key from the existing transmitter's Main AC Cutoff Switch padlock into the three-key transfer case (mounted on a wall). Turn the 'C' and 'D' keys, which locks them in place and releases the 'E' key.  
**NOTE:** If a second ATU hut is used, an 'H' key will also be released.
- (f) At the ATU Tuning Hut, insert and turn the 'E' key in ATU Grounding Switch '1', which releases the grounding arm mechanism. Operate the grounding arm. Once the grounding arm is in position, engage the bolt of key mechanism 'F', locking the grounding arm in the grounded position. This releases the 'F' key. **NOTE:** If a second ATU hut is used, the 'H' key is used in a similar manner to release the 'I' key.
- (g) Insert and turn the 'F' key in ATU Grounding Switch '2' which releases the grounding arm mechanism. Operate the grounding arm. Once the grounding arm is in position, engage the bolt of key mechanism 'G', locking the grounding arm in the grounded position. This releases the 'G' key.
- (h) Insert and turn the 'G' key in the ATU Access Door, releasing the door. The 'G' key will be locked in the key mechanism until the door is closed and locked again. **NOTE:** If a second ATU hut is used, the 'I' key is used in a similar manner to release the door.

To restore ac power, reverse step (a) through (h).



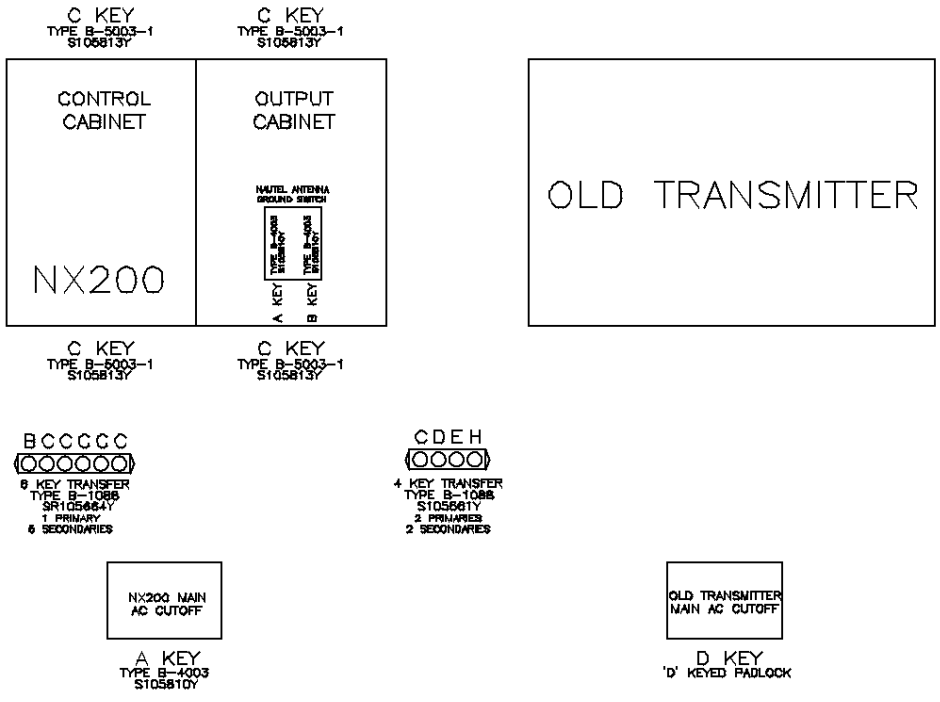
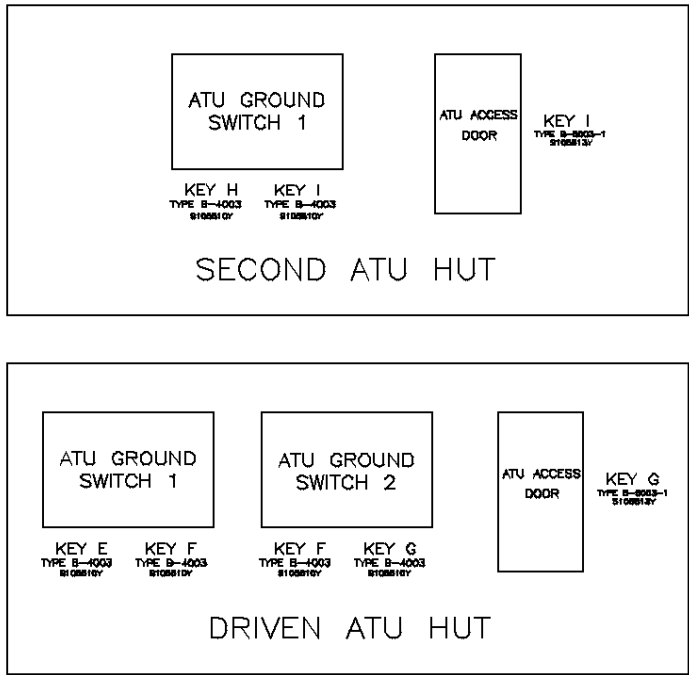

Figure 2-37: Typical Key Sequence Diagram for NX200 Transmitter Systems



## 2.5 COMMISSIONING AND OPERATION

These procedures are presented in a step-by-step format to permit a person who is not familiar with the transmitter system to perform the checks. Complete the procedures in sequence, as each procedure establishes settings and contains prerequisites for subsequent procedures.

### NOTE

*It is recommended that each transmitter's commissioning be performed while it is operating into the test load. This automatically routes the RF output of the other transmitter to the antenna. Ensure its power level is minimized or turned off during commissioning of the transmitter applied to the test load. Upon successful completion of commissioning, the operational transmitter can be routed to the antenna system.*

#### 2.5.1 Precautions to Observe

The transmitter system contains many solid-state devices that may be damaged if they are subjected to excessive heat or high voltage transients. Take every effort to ensure that the circuits are not overdriven, and that they are not disconnected from their loads while turned on.

The precautionary information included in the NX200 Transmitter's *Operations and Maintenance Manual* should be read and fully understood prior to applying power, and must be observed during operation.

#### 2.5.2 Preliminary Settings

Verify that the transmitter system is ready to turn on as follows:

Verify that the requirements of paragraphs 2.2 (Pre-Installation) and 2.3 (Installation) have been completed.

Verify that the ac power to transmitters A and B is turned off.

Ensure the interlock wiring is connected for the transmitter system and test load (see paragraph 2.3.10).

### WARNING

*If a jumper is placed between the **SYSTEM INTERLOCK** terminals (TB2-3 and 4) of the control/monitor assembly, safety features provided by the external interlocks will be disabled. A fail-safe method of alerting personnel to this fact should be implemented. Voltages that are dangerous to life will be present on RF output stages and the antenna system if the transmitter is turned on.*

Close the **SYSTEM INTERLOCK** or temporarily connect a jumper wire between terminals TB2-3 and TB2-4 of the control/monitor assembly.



### 2.5.3 Initial Operation

Turn on the transmitter system, test its primary functions, configure its remote and maximum power settings and begin “on-air” operation as follows:

#### NOTE

*The following procedure makes reference to operational controls on the NX200 Transmitter and on the control/monitor assembly. If necessary, refer to the NX200 Transmitter manuals for detailed operating instructions.*

*In this main-standby system, transmitter A is the Nautel NX200 transmitter and transmitter B is the existing on-site transmitter. Where applicable, refer to the existing transmitter's operating manual to perform similar tests to the NX200 Transmitter.*

- (a) Apply ac power to all components of the transmitter system (transmitters A and B, test load, 4-port switch, IMU, etc.). Confirm that the RF power for each transmitter is set to **RF Off**. Ensure the test load is operating properly.
- (b) Using each transmitter's front panel or remote AUI, configure and select a minimum power preset on both transmitters.

#### NOTE

*Before initiating a transmitter transfer with the control/monitor assembly's **SELECT TRANSMITTER TO ANTENNA** toggle switch, always make sure that the **RF** toggle switch is set to **INHIBIT**.*

*This transmitter system does not support automatic transfers. Only manual transfers - via the control/monitor assembly - are possible.*

- (c) From the control/monitor assembly's front panel (see Figure 2.3.10-4), set the **RF** toggle switch to **INHIBIT**, set the **SELECT TRANSMITTER TO ANTENNA** toggle switch to **XMTR B** (transmitter A to test load) and set the **MUTE** toggle switch to the **MUTE** position (enables the audible alarm).
- (d) When the 4-port switch has completed the transfer, the **TRANSMITTER TO ANTENNA - XMTR B** lamp should be on. Set the **RF** toggle switch to **ON**, which enables RF power.
- (e) While monitoring the forward power of transmitter A, press **RF On** on transmitter A.
- (f) Verify transmitter A is operating alarm free (i.e., no audible alarm) into the test load at minimum power preset.
- (g) Select the *Preset* for the assigned power level on transmitter A. Verify that transmitter A is operating at the correct power level according to its preset.
- (h) Set the control/monitor assembly's **RF** toggle switch to **INHIBIT** and set the **SELECT TRANSMITTER TO ANTENNA** toggle switch to **XMTR A** (transmitter B to test load). When the 4-port switch has completed the transfer, the **TRANSMITTER TO ANTENNA - XMTR A** lamp should be on. Set the **RF** toggle switch to **ON**, which enables RF power.
- (i) While monitoring the forward power of transmitter B, enable transmitter B's RF power.

- (j) Verify transmitter B is operating alarm free into the test load at the minimum power preset.
- (k) Select the assigned power level on transmitter B and verify it is operating at the correct power level.
- (l) Open an external interlock or remove the jumper from the **SYSTEM INTERLOCK** terminals (TB2-3 and TB2-4) on the control/monitor assembly. The forward power reading shall immediately fall to 0 W.
- (m) Close the external interlock or restore the jumper. The forward power reading shall be restored. Testing is complete.
- (n) Set the control/monitor assembly's **TRANSMITTER TO ANTENNA** toggle switch for the desired configuration (transmitter A or B to antenna) and set the transmitters for the desired power level. The system is not configured for automatic changeover operation.





